



# RF

## INTERCONNECT CATALOG

# COMPLETE RF INTERCONNECT SOLUTIONS

With the right mix of industry experts and knowledgeable engineers, Samtec can assist with challenges throughout a customer's system – including those specific to RF.

## TECHNICAL SUPPORT

- Launch Optimizations
- Simulations
- Test & Measurements
- Customs

RF Technical Group: [RFTechnicalGroup@samtec.com](mailto:RFTechnicalGroup@samtec.com)

Signal Integrity Group: [SIG@samtec.com](mailto:SIG@samtec.com)

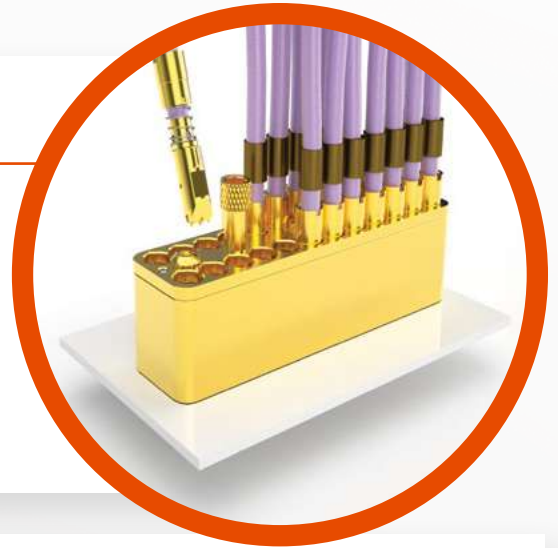

## PRECISION RF

- Bulls Eye® high-performance test to 50 GHz
- 34 / 40 / 50 / 65 GHz solutions
- Variety of options, including compression mount or blind-mate

## UNMATCHED SERVICE

- 24-hour samples and quotes
- No minimum order quantity on standards
- 2 to 5 day lead time on standard products



# TABLE OF CONTENTS

---

## Overview

Bulls Eye® High-Performance Test Systems .....	4-5
Precision RF .....	6
Customs and Mix-and-Match Solutions .....	7
50 $\Omega$ Cables and Connectors .....	8-9
75 $\Omega$ Cables and Connectors .....	10-11
Cable Selector Chart .....	12-13
Original Solutions .....	14

## 50 $\Omega$ and 75 $\Omega$ Cable Assemblies

Bulls Eye® High-Performance Test Systems .....	16-20
Micro High Frequency U.FL/W.FL Assemblies .....	22-23
50 $\Omega$ Cable Assemblies .....	24-36
75 $\Omega$ Cable Assemblies .....	37-40

## 50 $\Omega$ and 75 $\Omega$ Connectors

50 $\Omega$ (2.92 mm, SMA, SMP, SMB, MMCX, MCX, BNC, N Type, TNC) .....	42-54
75 $\Omega$ (DIN 1.0/2.3, HD-BNC™*, BNC, SMB) .....	55-60

## Original RF Solutions

100 $\Omega$ Shielded Twisted Pair System .....	62-63
Micro-Mini Ganged Systems .....	64-70
50 $\Omega$ Cable Assembly with High-Cycle U.FL Plug .....	71
75 $\Omega$ MMCX & MCX .....	72-73
IsoRate® Systems .....	74-77
Custom Solutions .....	78

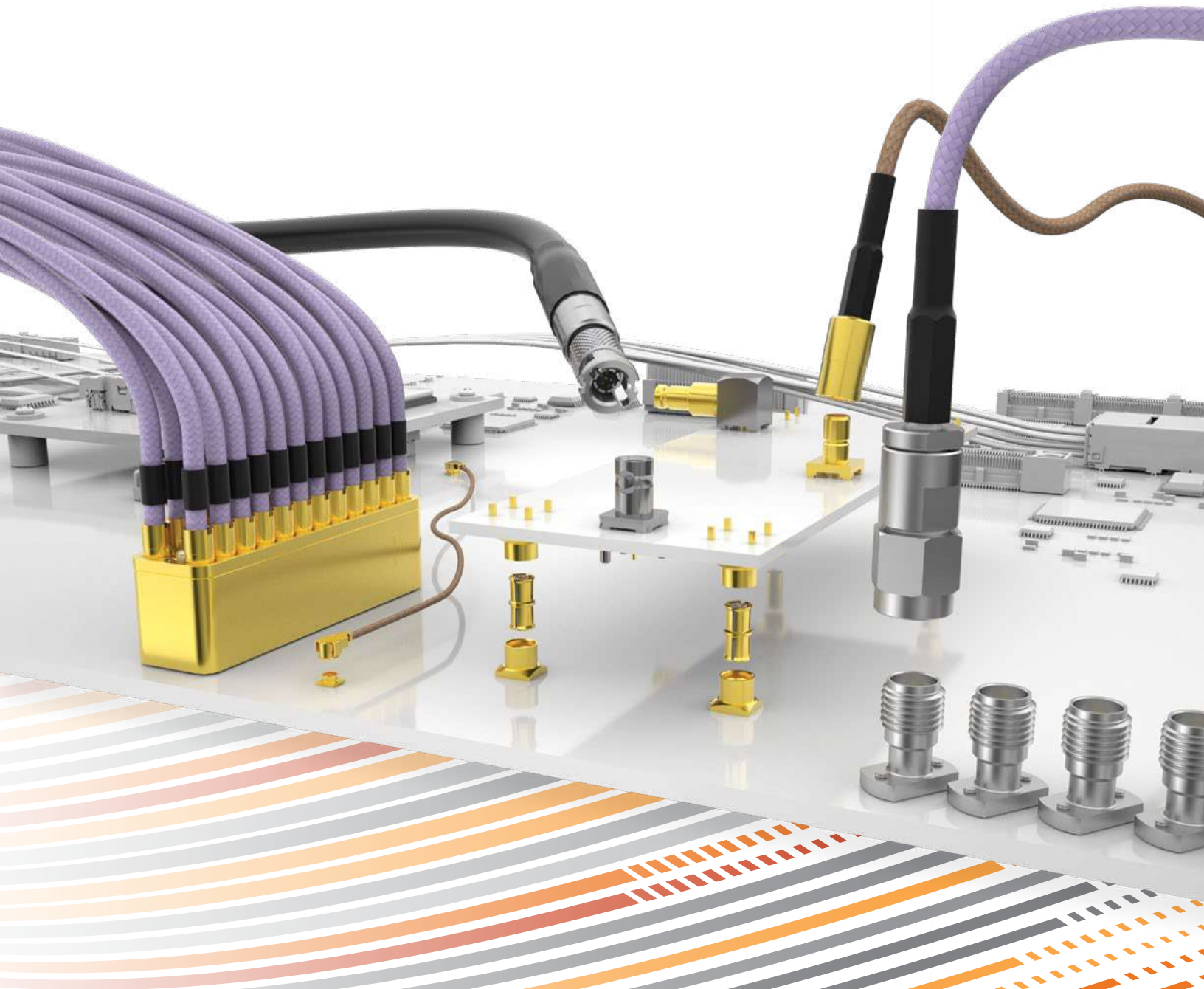

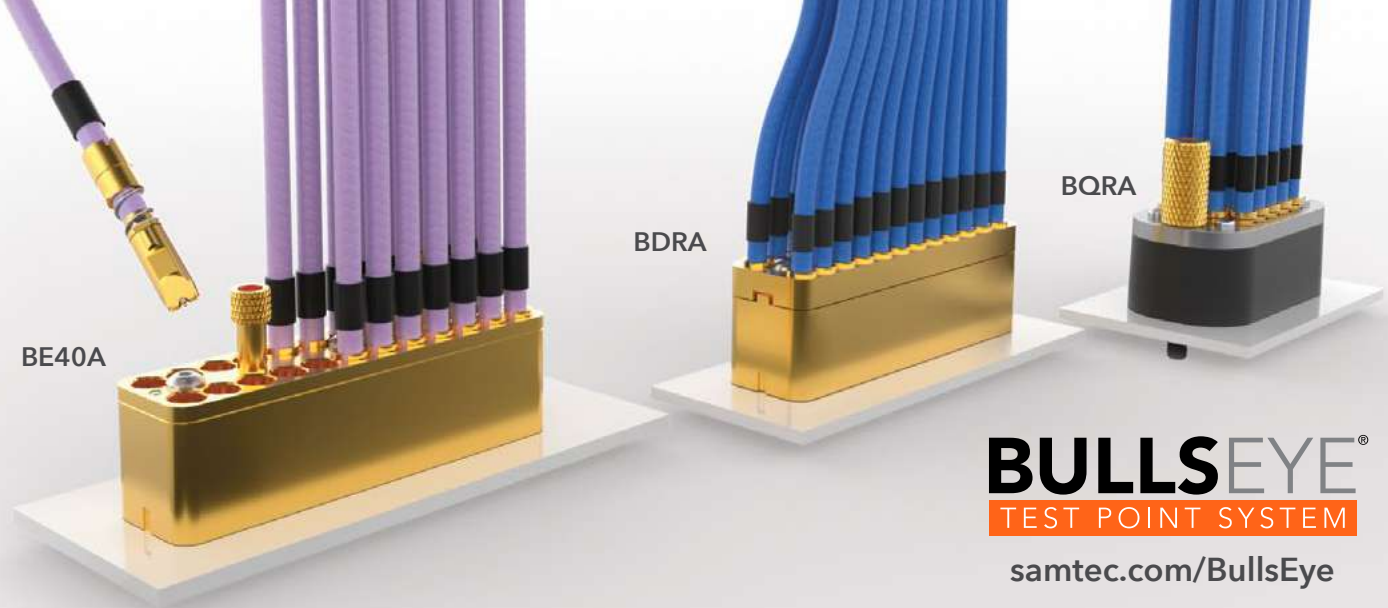

# HIGH-PERFORMANCE TEST TO 50 GHz

The high-density array designs and advanced cabling solutions within Samtec's Bulls Eye<sup>®</sup> product family enable optimized performance to 50 GHz. A compression interface, small footprint and high cycle count make Bulls Eye<sup>®</sup> ideal for high-performance test applications.

## Bulls Eye<sup>®</sup> Product Family Features:

- Compression interface to the board provides easy on/off and eliminates soldering costs
- Small footprint design significantly saves space on the board
- Microstrip or Stripline PCB transmission
- Assembly options: Dual Row (BE40A, BDRA) and Quad Row (BQRA)
- Installation: While the attach process for each series is similar, each have unique specifications that need to be observed. Contact [RFTechnicalGroup@samtec.com](mailto:RFTechnicalGroup@samtec.com).
- To 65 GHz in development

## Transmission Types:

- Two options: Microstrip (BE40A) or Stripline (BE40A, BDRA, BQRA)
- Compression interface to the board

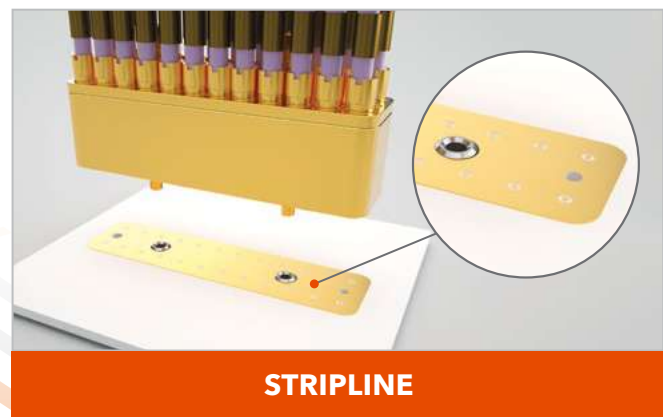
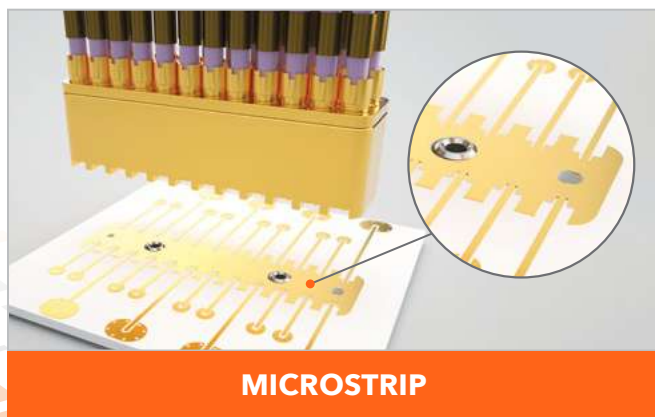

## BE40A SERIES 50 GHz, Double Row

- Enhanced system design with signal and ground pogo pins
- Microstrip or Stripline PCB transmission
- Backward compatible with BDRA Series
- 50  $\Omega$  impedance
- Positions: 2x 3, 4, 6, 8, 10, 12, 14, 16
- End 2 options: 2.92 mm, 2.4 mm also available
- 23 AWG solid dielectric, low loss microwave cable with additional copper shielding
- Replacement components available:  
Cables (BE40C Series) | Block (BE40B Series)

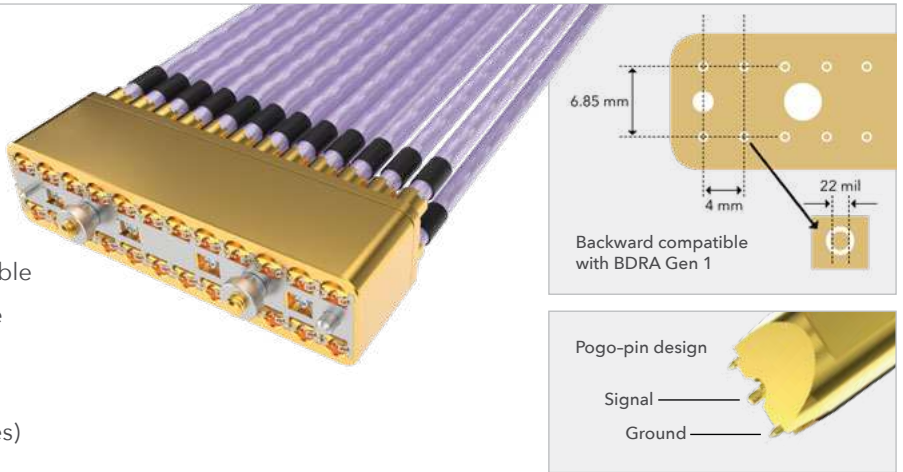

## BDRA SERIES 20 GHz, Double Row

- 23 AWG solid dielectric, low loss microwave cable
- Stripline PCB transmission
- Fixed-pin design
- 50  $\Omega$  impedance
- Positions: 2 x 12
- End 2 options: 2.92 mm, SMA also available
- Replacement components available:  
Cables (BE23S Series) | Block (BQR Series) | Elastomer

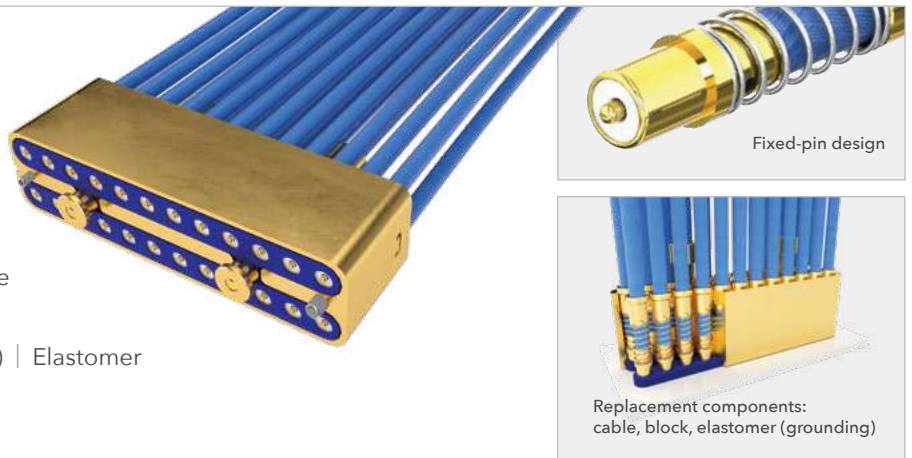

## BQRA SERIES 20 GHz, Quad Row

- 23 AWG solid dielectric, low loss microwave cable
- Stripline PCB transmission
- Fixed-pin design
- 50  $\Omega$  impedance
- Positions: 20 (Quad Row)
- End 2 options: 2.92 mm, SMA also available
- Replacement components available:  
Cables (BE23S Series) | Block (BDR Series) | Elastomer

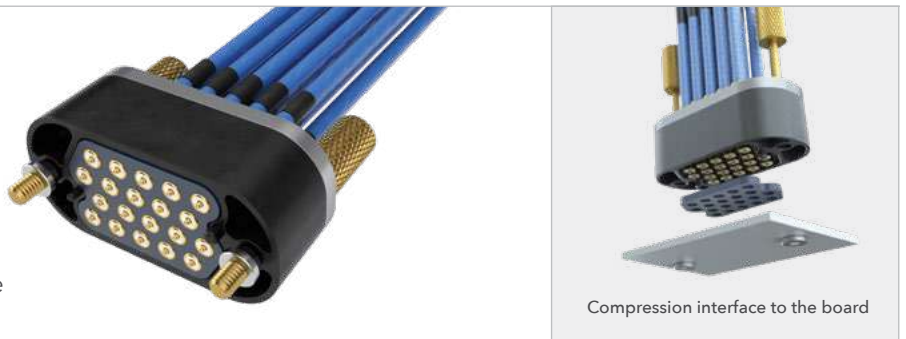

Series	BE40A	BDRA	BQRA	Replacement Components
Cable	23 AWG, additional shielding	23 AWG, additional shielding		For BE40A: BE40C, BE40B For BDRA: BE23S, BDR For BQRA: BE23S, BQR
PCB Transmission	Microstrip or Stripline	Stripline		
Ground	Pogo-pin design on Bulls Eye® probe end	Elastomer		
Positions	2 x 3, 4, 6, 8, 10, 12, 14, 16	2 x 12	20 (Quad Row)	
Frequency (GHz)	Up to 50	Up to 20		
Page	17	18	19	20

65 GHz high-performance test solution in development.

# PRECISION INTERCONNECTS

**ROADMAP** | [RFTechnicalGroup@samtec.com](mailto:RFTechnicalGroup@samtec.com)

**34 GHz**

**3.50 mm**

- Edge mount with screw downs
- High-performance microwave cable assembly: 23 AWG (RF23S Series)

**40 GHz**

**2.92 mm**

- Compression mount with 2-hole flange in various board thicknesses
- High-performance microwave cable assembly: 23 AWG (RF23C Series)

**SMP**

- Straight & right-angle, full detent & smooth bore
- Blind-mate with axial alignment
- High-performance microwave cable assembly: 24 AWG (RF405 Series), 25 AWG (RF25S Series) and .047 Cable (in development)

**50 GHz**

**2.40 mm**

- Compression mount with 2-hole flange in various board thicknesses
- High-performance microwave cable assembly: 23 AWG (RF23C Series)

**65 GHz**

**1.85 mm**

- Compression mount with 2-hole flange in various board thicknesses

**SMPM**

- Straight & right-angle, full detent & smooth bore
- Blind-mate with axial alignment
- High-performance microwave cable assembly: .047 Cable (in development)



<b>Precision Interconnects (mm)</b>	3.5	2.92, SMP	2.4	1.85, SMPM
<b>Performance (GHz)</b>	34	40	50	65

**Bulls Eye® High-Performance Test Array**

High-density array design significantly saves space on the board compared to traditional test points.

**See pages 4-5.**

Wide variety of Precision interconnects for high-performance testing.

# MIX-AND-MATCH END OPTIONS

on standard cable assemblies, with standard pricing and lead times

View series-specific catalog pages for all end options and details. Or, use the charts below as a quick reference guide.

HIGH FREQUENCY MICROWAVE				50 Ω RF CABLES				75 Ω RF CABLES			
CABLE	AWG	END OPTIONS	SERIES	CABLE	AWG	END OPTIONS	SERIES	CABLE	AWG	END OPTIONS	SERIES
MWC-2350CU-01	23	2.92 mm, 2.4 mm, SMA, SMP	RF23C	0.81	36	MHF1, MHF3, SMA	MH081	RG 179	30	MCX, MMCX7, SMB, BNC, DIN 1.0/2.3	RF179, GRF7-C, GRF7H-C
MWC-2350-01	23	3.50 mm	RF23S	1.13	32	MHF1, SMA	MH113	1855A	23	BNC, HD-BNC™, DIN 1.0/2.3	RFB8T
MWC-2550-01	25	SMA, SMP	RF25S	RG 178	30	MMCX, MCX, SMA, SMB, BNC, TNC, N Type	RF178	1694A	18		RFB6T
CCA-047	28	HMHF1, SMA	RF047	RG 174	26	MMCX, MMCXV, MCX, SMA, SMB, BNC, TNC, N Type	RF174	RG 6	18		RFA6T
RG 405	24	SMA, SMP	RF405	RG 316	26	MMCX, MMCXV, MCX, SMA, SMB, BNC, TNC, N Type	RF316, IJ5C, IJ5H, GRF1-C, GRF1H-C				
RG 402	19	SMA	RF402	RG 58	20	SMA, TNC, N Type	RF058				

## rf.samtec.com | Solutionator® Online RF Assembly Builder

Solutionator is Samtec's online parametric filter that lets you easily choose your product and board-level mate in a matter of minutes. It also connects you directly to:



**LIVE CHAT** with an RF engineer

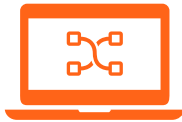

**VIEW** engineering drawings



**REQUEST** samples and quotes

# CUSTOM SOLUTIONS

28% of Samtec's total sales are in customs or product modifications. This includes RF. Why is this? Samtec has the willingness, expertise and service to make it happen.

**23%** Express Modifications  
92% do not require engineering or tooling charges

**5%** Engineered Customs

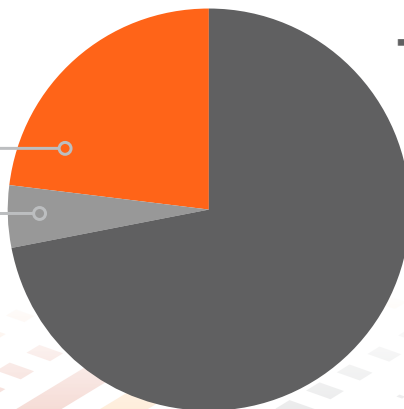

## TOTAL SALES

See additional details on **page 78** regarding RF Express or Engineered customs.

# 50 Ω RF CABLES & CONNECTORS



## WIDE VARIETY OF CABLES

- High frequency microwave cables:
  - Hand-formable semi-flexible cables at .047" DIA, .086" DIA or .141" DIA
  - 23 AWG or 25 AWG solid dielectric cables to 50 GHz
  - 10 GHz, 500 cycle U.FL HMHF1 plug terminations
- Micro High Frequency U.FL/W.FL cable assemblies
- Industry standard cables with mix-and-match end options:
  - RG 316, RG 174, RG 178, RG 58
- Double-shielded RG 316 cable for approx. 75 dB shielding effectiveness

## PRECISION INTERCONNECTS

See page 6



## 50 Ω HIGH FREQUENCY CABLE ASSEMBLIES

Series	RF405	RF402	RF23C	RF23S	RF25S
Type	0.86" DIA	.141" DIA	23 AWG		25 AWG
Type Cable	Hand-formable, semi-flexible		Solid dielectric, microwave		
Terminations	SMA, SMP	SMA	2.92 mm, 2.40 mm	3.50 mm	SMA, SMP
Page	32	33	34	36	36

## 50 Ω STANDARD CABLE ASSEMBLIES

MH081/MH113	RF174/RF316	RF178	RS316	RF058
U.FL & W.FL	Commodity components & assemblies			
0.81 mm/1.13 mm	RG 174/RG 316	RG 178	RG 316 double-shielded	RG 58
MHF1, MHF3, SMA	SMA, SMB, MCX, MMCX, MMCXV, BNC, TNC, N Type	SMA, SMB, MCX, MMCX, BNC, TNC, N Type	SMA	SMA, TNC, N Type
22-23	24-25, 28-29	26-27	30	31





### WIDE VARIETY OF TERMINATIONS

- MHF (U.FL/W.FL), HMHF1 (High Cycle U.FL)
- 2.92 mm, 2.40 mm, 3.50 mm, SMA, SMP, SMB, MCX, MMCX, BNC, TNC, N Type and high vibration MMCX (MMCXV)
- Straight and right-angle available for most; variety of jacks and plugs
- Bulkhead jack options

### BOARD LEVEL INTERCONNECTS

- Straight or right-angle orientations
- Through-hole, surface mount, edge mount or mixed technology
- 2.92 mm, SMA, SMB, SMP, MCX, MMCX, BNC and TNC
- MMCX jacks/plugs and switchable internal/external antenna jack

- SMP Plugs & Adaptors
  - Compensates for misalignment in X & Y directions
  - Bullet adaptor allows for flexible connections
  - Frequency range: DC to 40 GHz

### 50 Ω BOARD LEVEL INTERCONNECTS

Series	292	SMA	SMP	SMB5	MMCX*	MCX	BNC5
Type	2.92 mm	SMA	Floating System	SMB	MMCX	MCX	BNC
Orientation	Straight	Straight, Right-Angle		Right-Angle	Straight, Right-Angle		
Terminations	Panel Mount	T/H, SM, MT, Edge Mount	T/H, MT, Edge Mount	T/H	T/H, SM, MT, Edge Mount	T/H, SM, MT, Edge Mount	T/H
Page	42-43	44-46	47	48	49, 51	50-51	52

\* High vibration available. Contact Samtec.

# 75 Ω RF CABLES & CONNECTORS



## WIDE VARIETY OF CABLES

- Industry standard cables with mix-and-match end options: RG 179, RG 6, Belden 1694A, Belden 1855A
- RFB8T Series (with Belden 1855A cable)
- Components are available for customer-installed field termination to cable

## WIDE VARIETY OF TERMINATIONS

- BNC, HD-BNC™, DIN 1.0/2.3
- 75 Ω SMB to 8 GHz
- Straight and right-angle orientations
- Die cast options available
- Unique-to-Samtec Mini and Micro-mini components with higher extraction force
- See page 14 for board mates (MCX7, MMCX7)

## BOARD LEVEL INTERCONNECTS

- 12G-SDI Broadcast Video Solutions: BNC, HD-BNC™, DIN 1.0/2.3
- Through-hole, surface mount, edge mount and straight or right-angle orientations
- SMB, DIN 1.0/2.3, HD-BNC™, BNC jacks
- BNC includes low-profile, right-angle
- HD-BNC™ for high-density applications
- 75 Ω SMB jacks

## 75 Ω STANDARD CABLE ASSEMBLIES

Series	RFA6T	RFB6T	RF179	RFB8T
Type	Commodity components & assemblies			
Type Cable	RG 6	1694A	RG 179	1855A
Terminations	HD-BNC™, BNC, DIN 1.0/2.3	HD-BNC™, BNC, DIN 1.0/2.3	MMCX7, MCX, SMB, BNC, DIN 1.0/2.3	HD-BNC™, DIN 1.0/2.3
Page	37	37	38-39	40

\* HD-BNC™ is a trademark of Amphenol.



### HD-BNC



HD-BNC™      BNC

#### HIGH-DENSITY BNC SYSTEMS

- 4X the panel density of traditional BNCs
- Patented design and bayonet latch
- 20% reduction in weight of traditional BNCs
- Crimp style plugs use industry standard termination tools
- Compatible with Amphenol's HD-BNC™

**BROADCAST VIDEO SOLUTIONS** 

[samtec.com/12GSDI](http://samtec.com/12GSDI)

Samtec has the largest variety of 12G-SDI products available: BNC, HD-BNC™ and DIN 1.0/2.3 with a variety of orientation and termination options including low-profile, right-angle.

Contact [RFTechnicalGroup@samtec.com](mailto:RFTechnicalGroup@samtec.com) for more information.

#### 75 Ω BOARD LEVEL INTERCONNECTS

Series	DIN7A	HDBNC	BNC7T	SMB7H
Type	DIN 1.0/2.3	High-Density BNC	BNC	SMB
Orientation	Straight, Right-Angle	Straight, Right-Angle	Straight, Right-Angle	Straight, Right-Angle
Terminations	T/H	T/H, Edge Mount	T/H, Edge Mount	T/H, Edge Mount
Page	55	56-57	58-59	60
12G-SDI	✓	✓	✓	

# RF CABLE SPECIFICATIONS



CABLE TYPE		50 Ω CABLES							
		0.81	1.13	RG 178	CTB-2650F-01	RG 174	RG 316	RG 316 DS	RG 58
Impedance	Ω	50 ± 3	50 ± 2		50 ± 5	50 ± 2	50 ± 3		
Attenuation (dB/m)	100 MHz	1.0	0.6	0.5	0.68	0.4	0.3	1.4 @ 2 GHz	0.2
	1 GHz	3.1	1.9	1.7	2.37	1.4	1.25	1.6 @ 3 GHz	0.8
	6 GHz	8.6	4.9	5.9	6.53	4.4	4.25	2.2 @ 5 GHz	5.4
Dielectric Constant (dk)	-----	2.0		2.1	1.56	2.3	2.1		2.3
Dielectric Strength	VAC	1000	500	1000	-----	500	1200	-----	1400
Propagation Delay	nS/m	4.70		4.83	4.17	5.06	4.83	-----	5.05
Current Rating	Amps	1.2	2.1	3	3	5	5	-----	-----
Capacitance	pF/m	100	95	96	85.6	101	96	95.8	102
Center Conductor	Material	Silver Plated Copper		Silver Plated Copper Clad Steel	Silver Plated Copper	Bare Copper	Silver and Copper Plated Steel	Silver Plated Copper Clad Steel	Tinned Copper
	AWG	36	32	30	26	26	26	26	20
	Stranding (No./mm)	7/0.05	7/0.076	7/0.10	19/0.10	7/0.16	7/0.17	7	19/0.018
	Diameter (mm)	0.15	0.23	0.31	0.48	0.48	0.51	0.53	0.80
	Max Resistance (Ω/m)	1.40	0.60	0.34	0.12	0.14	0.13	-----	-----
Dielectric	Material	FEP		PTFE	Foamed FEP	KLPE	PTFE	FEP	Solid Polyethylene
	Diameter (mm)	0.40	0.68	0.84	1.29	1.52	1.52	1.53	3.00
Shield	Material	Silver Plated Copper	Tinned Copper	Silver Plated Copper		Tinned Copper	Silver Plated Copper		Tinned Copper
	Diameter (mm)	0.65	0.89	1.37	1.5	2.57	1.73	2.38	3.81
Jacket	Material	PFA	FEP			PVC	FEP		PVC
	Diameter (mm)	0.81	1.13	1.80		2.79	2.53	2.90	5.00
	Temp Rating	-40 °C to +90 °C		-50 °C to +165 °C	-40 °C to +200 °C	-20 °C to +80 °C	-55 °C to +165 °C	-----	-50 °C to +90 °C
	Color	Gray		Brown	Blue	Black	Brown		Black
Bend Radius	Min	5 mm	6.8 mm	10.2 mm	3.175 mm	25.4 mm	12.7 mm	12.8 mm	48.3 mm
Termination Options		MHF1, MHF3, SMA	MHF1, SMA	MMCX, MCX, SMA, SMB, BNC, TNC, N Type	IsoRate®	MMCX, MMCXV, MCX, SMA, SMB, BNC, TNC, N Type, Ganged	MMCX, MCX, SMA, BNC, TNC	SMA, TNC, N Type	
Samtec Series		MH081	MH113	RF178	IJ5C	RF174	RF316, IJ5C, IJ5H, GRF1-C, GRF1H-C	RS316	RF058



50 Ω MICROWAVE CABLES						75 Ω MICROWAVE CABLES				100 Ω CABLES
MWC-2550-01	MWC-2350-01	MWC-2350CU-01	CCA-047 (.047")	RG 405 (.086")	RG 402 (.141")	RG 179	BELDEN 1855A	BELDEN 1694A	RG 6	TPS-28100-RF
50 ± 1			50 ± 2			75 ± 3				100 ± 5
0.65 @ 1 GHz	0.17		0.80 @ 0.5 GHz	0.72 @ 1 GHz	0.40 @ 1 GHz	0.3	0.12	0.07		-----
1.37 @ 4 GHz	0.7		1.15	2.59 @ 4 GHz	1.04 @ 4 GHz	0.8	0.37	0.21		-----
3.36 @ 20 GHz	1.7		2.62 @ 4 GHz	4.26 @ 20 GHz	2.30 @ 20 GHz	3.6	0.97	0.59		-----
2.1	2.15		2.1	2.04	1.99	1.8	1.42	1.44		2.1
-----	300		-----	1000		1200	300		2000	-----
4.76	4.72	4.76	-----	4.79		4.83	4.12	4.06	4.03	-----
5.3	7.4		-----	-----	-----	3	5	-----	-----	-----
96.8	95.45	97.80	95.14	104.97	98.072	64	55.7	53.14		38
Silver Plated Copper				Silver Plated Copper Clad Steel	Silver Plated Copper Clad Steel	Silver Plated Copper	Bare Copper			Silver Plated Copper
25	23		28	24	19	30	23	18		28
1/0.45	1/0.57		1/0.29	1/0.51	1/0.92	7/0.10	1/0.58	1/1.02		2/0.85
0.45	0.57		0.29	0.51	0.92	0.30	0.58	1.02		1.97
0.105	0.071		-----	0.67	0.02	0.34	0.066	0.021		0.029
Solid FEP			FEP	PTFE	PTFE	PTFE	FHDPE	FHDPE		FEP
1.46	1.85		0.92	1.68	2.98	1.58	2.59	4.57		1.97
1. Flat Silver Plated Copper 2. Silver Plated Copper Braid		1. Flat Silver Plated Copper 2. Copper Tape 3. Silver Plated Copper Braid	1. Flat Silver Plated Copper 2. Silver Plated Copper Braid	Tinned Copper		Silver Plated Copper	1. Al Foil-Polyester Tape-Al Foil 2. Tinned Copper	1. Bonded Al Foil 2. Al Wire	1. Al Foil-Polyester Tape-Al Foil 2. Tinned Copper	Silver Plated Copper
1.87	2.25		1.12	2.20	3.58	2.13	3.00	-----	-----	2.41
FEP			-----	-----	-----	FEP	PVC	PVC		PVC
2.06	2.59		1.42	-----	-----	2.54	4.04	6.96	7.00	3.66
-40 °C to +200 °C			-65 °C to +165 °C	-40 °C to +125 °C		-50 °C to +165 °C	-30 °C to +75 °C	-30 °C to +75 °C		-20 °C to +105 °C
Blue		Violet	Brown	-----	-----	Brown	Black			Blue
9 mm	12 mm	6 mm	10 mm	3.18 mm	6.35 mm	10.2 mm	38.1 mm	69.85 mm		19.05 mm
SMA, SMP	3.50, 2.92	2.92, 2.40, SMA, SMP	HMHF1 (U.FL), SMA	SMA, SMP	SMA	MCX, MMCX7, SMB, BNC, DIN 1.0/2.3, Ganged	HD-BNC™, DIN 1.0/2.3	BNC, HD-BNC™, DIN 1.0/2.3		CJT
RF25S	BDRA, BQRA, RF23S	RF23C, BE40A	RF047	RF405	RF402	RF179, GRF7-C, GRF7H-C	RFB8T	RFB6T	RFA6T	C28S

# ORIGINAL RF SOLUTIONS

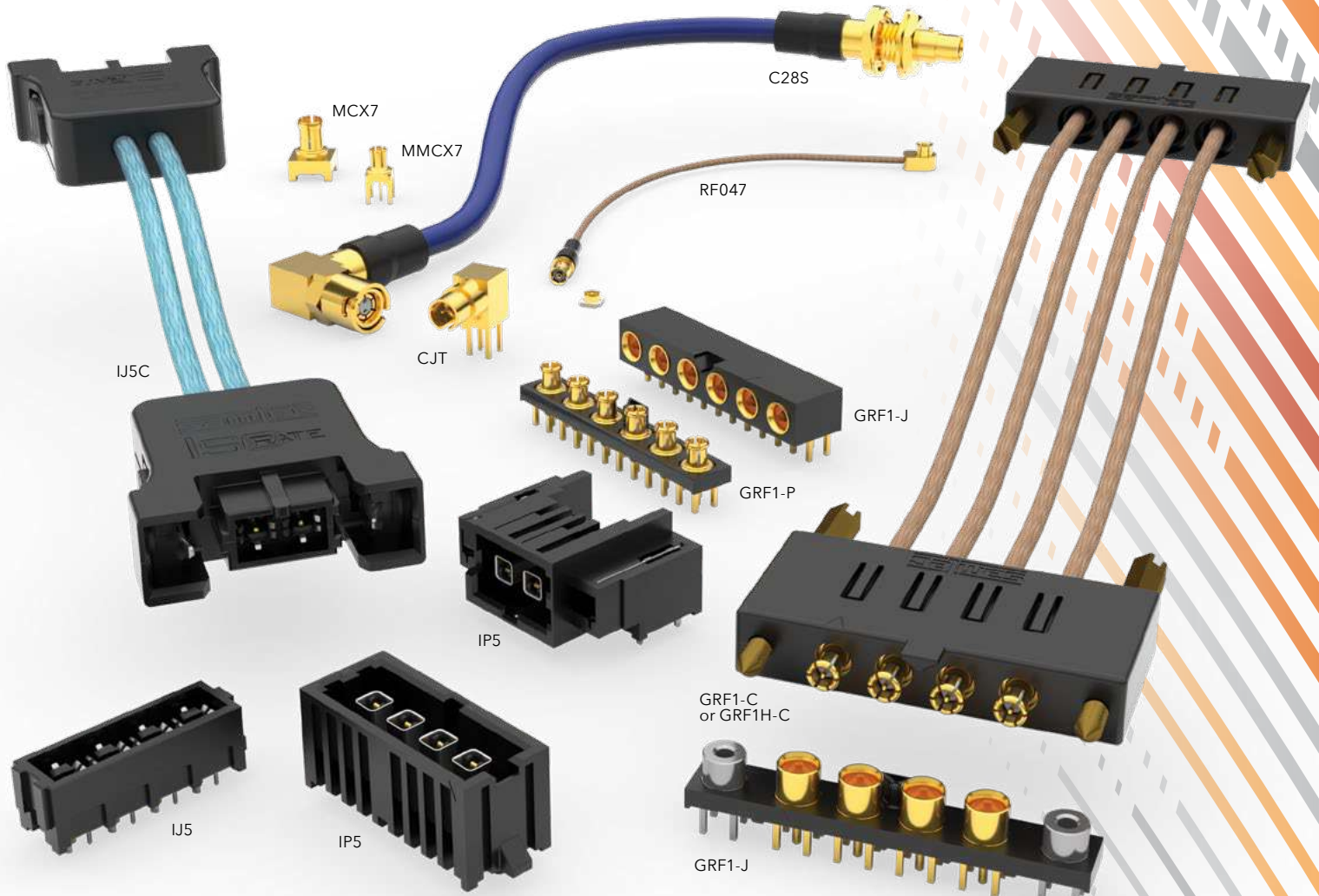

## SHIELDED TWISTED PAIR SYSTEM

- 100  $\Omega$  differential pair
- 28 AWG shielded twisted pair cable assembly
- High reliability BeCu contacts
- 1/4-turn bayonet lock

## GANGED MICRO-MINI SYSTEMS

- 50  $\Omega$  & 75  $\Omega$  board stacking and cable assemblies
- High performance rugged contacts
- Variety of End 2 options (GRF1H, GRF7H Series)

## ISORATE® SYSTEMS

- 50  $\Omega$  board stacking and cable assemblies
- Isolated signal systems for 90 percent performance of traditional RF at 50 percent of the cost

## MINI & MICRO-MINI INTERCONNECTS

- Higher extraction forces
- Not intermateable with standard MMCX, MCX

## HIGH-CYCLE U.FL CABLE PLUG

- 500 cycle U.FL compatible plug (HMHF1)
- .047" DIA flexible cable (RF047 Series)

## CABLE SOLUTIONS

Series	C28S/CJT	GRF1-C	GRF1H-C / GRF7H-C	RF047	IJ5C/IJ5H
Application	Shielded Twisted Pair	50 $\Omega$ Micro-Mini Ganged	50 & 75 $\Omega$ Micro-Mini Hybrid Ganged	50 $\Omega$ .047 DIA flexible cable	50 $\Omega$ IsoRate®
Page	62-63	65	66-69	71	74-75

## BOARD-TO-BOARD SOLUTIONS

Series	GRF1-P/GRF1-J	GRF7-P/GRF7-J	MMCX7	MCX7	IJ5/IP5
Application	50 $\Omega$ Micro-Mini Ganged	75 $\Omega$ Micro-Mini Ganged	75 $\Omega$ Mini and Micro-Mini Interconnects		50 $\Omega$ IsoRate®
Page	64	70	72	73	76-77



# BULLS EYE®

## HIGH PERFORMANCE TEST SYSTEMS

Bulls Eye® Cross Reference Chart .....	16
50 GHz, Double Row, 23 AWG Cable Assembly (BE40A) .....	17
20 GHz, Double Row, 23 AWG Cable Assembly (BDRA) .....	18
20 GHz, Quad Row, 23 AWG Cable Assembly (BQRA) .....	19

## REPLACEMENT COMPONENTS

Replacement Block for BE40A Series Bulls Eye® Assembly (BE40B) .....	20
Replacement Cable for BE40A Series Bulls Eye® Assembly (BE40C) .....	20
Replacement Block for BDRA Series Bulls Eye® Assembly (BDR) .....	20
Replacement Block for BQRA Series Bulls Eye® Assembly (BQR) .....	20
Replacement Cable for BDRA & BQRA Series Bulls Eye® Assembly (BE23S) .....	20

## APPLICATIONS

Bulls Eye® High-Performance Test to 50 GHz .....	4-5
--------------------------------------------------	-----

# HIGH-PERFORMANCE TEST TO 50 GHz

**BULLSEYE®**  
TEST POINT SYSTEM

[samtec.com/BullsEye](http://samtec.com/BullsEye)

Compression interface design, small footprint and high-cycle count make Bulls Eye® ideal for high-performance test applications.

## BULLS EYE® SERIES CROSS REFERENCE

	BE40A	BDRA	BQRA
Performance	50 GHz	20 GHz	
End 2 Options	2.40 mm Jack / Plug (50 GHz), 2.92 mm Jack/Plug	2.92 mm Jack / Plug	
Cable Type	23 AWG, Double Row, Copper Foil Shield	23 AWG, Double Row	23 AWG, Quad Row
Cable Management	Yes		
PCB Transmission	Microstrip or Stripline	Stripline	
Ground	Pogo-pin design on Bulls Eye® probe end	Elastomer	
No. of Positions	2x 3, 4, 6, 8, 10, 12, 14, 16	2x 12	20 (Quad Row)
Impedance	50 Ω		
Future Proof	BE40A is backward compatible with BDRA		N/A

Test assemblies up to 65 GHz are in development.

Replacement components are available (cables, blocks, elastomer) – See page 20.

## INSTALLATION

Samtec offers a variety of series within the Bulls Eye® product family for meeting customer's criteria.

While the attach process is similar, each have unique specifications that need to be observed.

For questions, please contact [RFTechnicalGroup@samtec.com](mailto:RFTechnicalGroup@samtec.com).



BE40A



BDRA



BQRA

Due to technical progress, all designs, specifications and components are subject to change without notice.

[WWW.SAMTEC.COM](http://WWW.SAMTEC.COM)

All parts within this catalog are built to Samtec's specifications.

Customer specific requirements must be approved by Samtec and identified in a Samtec customer-specific drawing to apply.



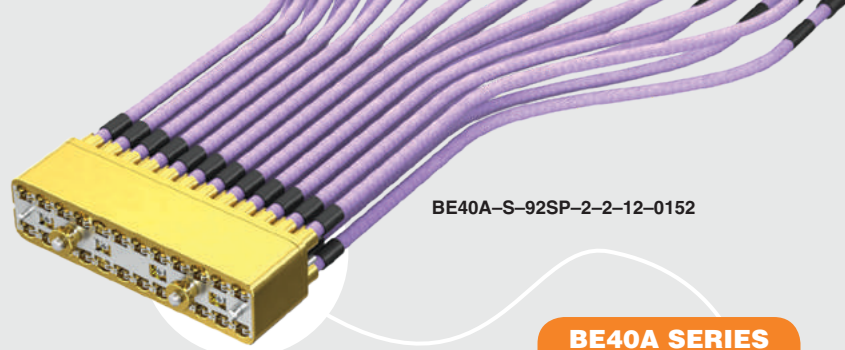

BE40A-S-92SP-2-2-12-0152

**BE40A SERIES**

# 50 GHz DOUBLE ROW TEST ASSEMBLY

## SPECIFICATIONS

For complete specifications see [www.samtec.com?BE40A](http://www.samtec.com?BE40A)

### End 2 Connector:

**Shell Material:** Stainless Steel  
**Contact Material:** BeCu

**Cable Body:** Stainless Steel  
**Insulator Material:** Ultem 1000

**Operating Temperature:** -65 °C to +165 °C

**Impedance:** 50 Ω

**Frequency Range:** 50 GHz

**RoHS Compliant:** Yes

### MWC-2350CU-01

#### Cable:

**Type:** Low Loss Microwave Coax

**Gauge:** 23 AWG

**Shield Material:**  
1. Flat silver plated copper  
2. Copper tape  
3. Silver plated copper braid

**Dielectric:** Solid FEP

**Jacket Material:** FEP

**Bend Radius:** 6 mm

**Impedance:** 50 Ω ±1 Ω

**Propagation Delay:** 4.76 nsec/meter

**Capacitance:** 97.80 pF/meter

## TEST REPORTS

Visit [www.samtec.com?BE40A](http://www.samtec.com?BE40A) or contact [RFTechnicalGroup@samtec.com](mailto:RFTechnicalGroup@samtec.com) for Insertion Loss, Return Loss, V.S.W.R. and other testing information.

## COMPONENTS

- For replacement cable see [www.samtec.com?BE40C](http://www.samtec.com?BE40C)
- For replacement block see [www.samtec.com?BE40B](http://www.samtec.com?BE40B)

Backward compatible with BDRA Gen 1

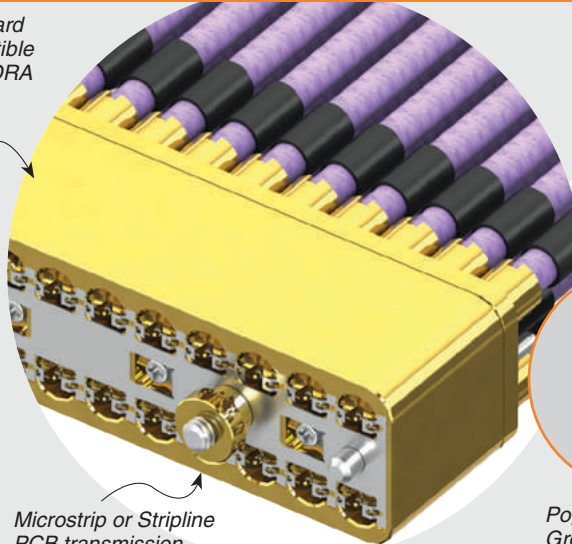

Microstrip or Stripline PCB transmission

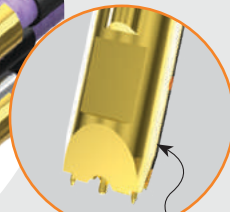

Pogo-pin design with Ground/Signal/Ground

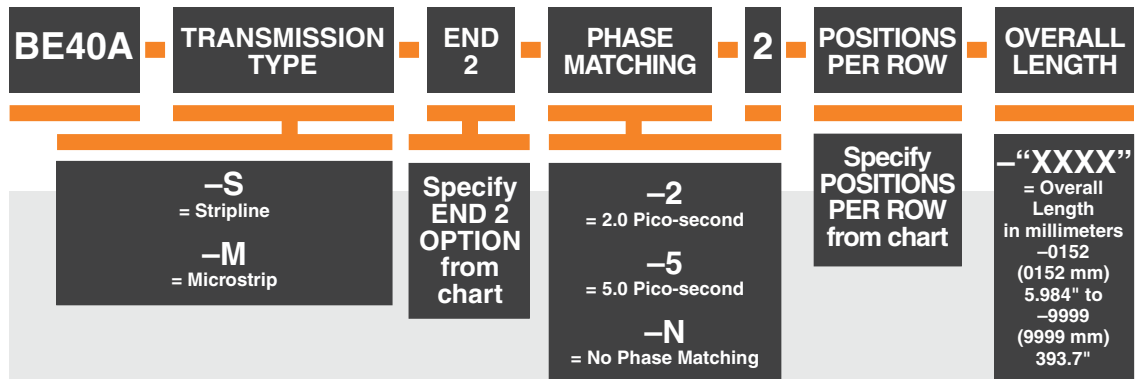

POSITIONS PER ROW	A	B
-03	(13.80) .543	N/A
-04	(17.80) .701	(14.80) .583
-06	(25.80) 1.016	(22.80) .898
-08	(33.80) 1.331	(30.80) 1.213
-10	(41.80) 1.646	(38.80) 1.528
-12	(49.80) 1.961	(46.80) 1.709
-14	(57.80) 2.276	(54.80) 2.157
-16	(65.80) 2.591	(62.80) 2.472

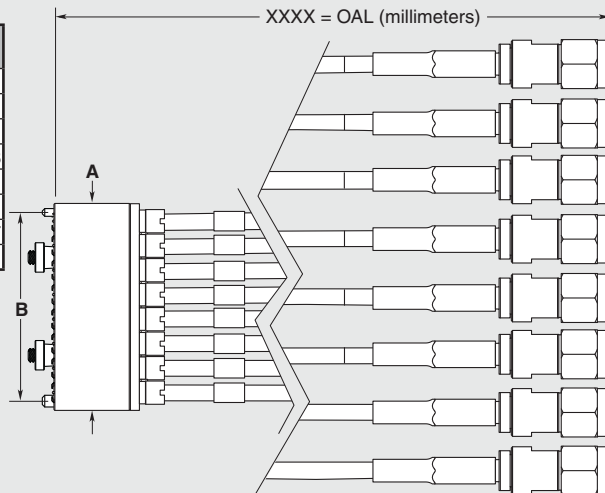

BE40A-S-92SP-XX-2-08-XXXX SHOWN

*-24SJ & -24SP PRELIMINARY*

END 2 OPTIONS*	
-92SJ = 2.92 mm -24SJ* = 2.40 mm Straight Jack	
(30 μ" (0.76 μm) Gold on Center Contact, Stainless Steel on Shell)	
-92SP = 2.92 mm -24SP* = 2.40 mm Straight Plug	
(30 μ" (0.76 μm) Gold on Center Contact, Stainless Steel on Shell)	

\* 2.40 mm end option is needed for 50 GHz performance. Contact [RFTechnicalGroup@samtec.com](mailto:RFTechnicalGroup@samtec.com)

**Notes:**  
Cable lengths longer than 40.00" (1 meter) are not supported with S.I. test data

Some lengths, styles and options are non-standard, non-returnable.

Due to technical progress, all designs, specifications and components are subject to change without notice.

[WWW.SAMTEC.COM](http://WWW.SAMTEC.COM)

All parts within this catalog are built to Samtec's specifications. Customer specific requirements must be approved by Samtec and identified in a Samtec customer-specific drawing to apply.

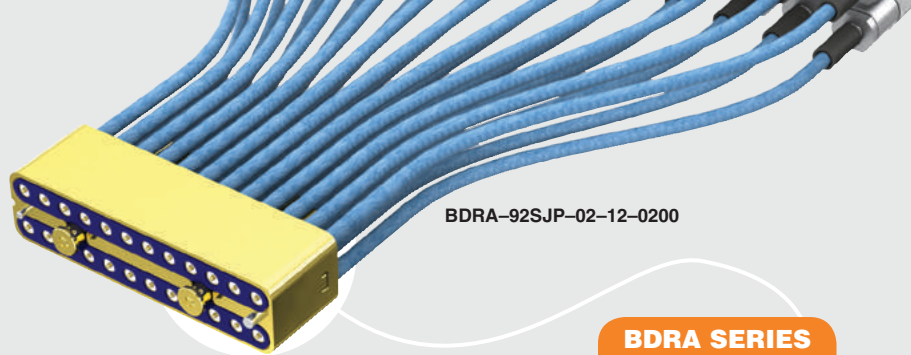

BDRA-92SJP-02-12-0200

**BDR SERIES**

# 20 GHz DOUBLE ROW TEST ASSEMBLY

**SPECIFICATIONS**

For complete specifications see [www.samtec.com?BDRA](http://www.samtec.com?BDRA)

**End 2 Connector:**

**Shell Material:** Stainless Steel  
**Contact Material:** BeCu

**Cable Body:** Stainless Steel  
**Insulator Material:** Ultem 1000

**Operating Temperature:** -65 °C to +165 °C

**Impedance:** 50 Ω

**Frequency Range:** 20 GHz

**RoHS Compliant:** Yes

**MWC-2350-01**

**Cable:**

**Cable Type:** Low Loss Microwave Coax

**Gauge:** 23 AWG

**Shield Material:**  
1. Flat silver plated copper  
2. Silver plated copper braid

**Dielectric:** Solid FEP

**Jacket Material:** FEP

**Bend Radius:** 12 mm

**Impedance:** 50 Ω ± 1 Ω

**COMPONENTS**

- For replacement cable see [www.samtec.com?BE23S](http://www.samtec.com?BE23S)
- For replacement block see [www.samtec.com?BDR](http://www.samtec.com?BDR)
- Replacement elastomer gaskets available  
Contact Samtec.

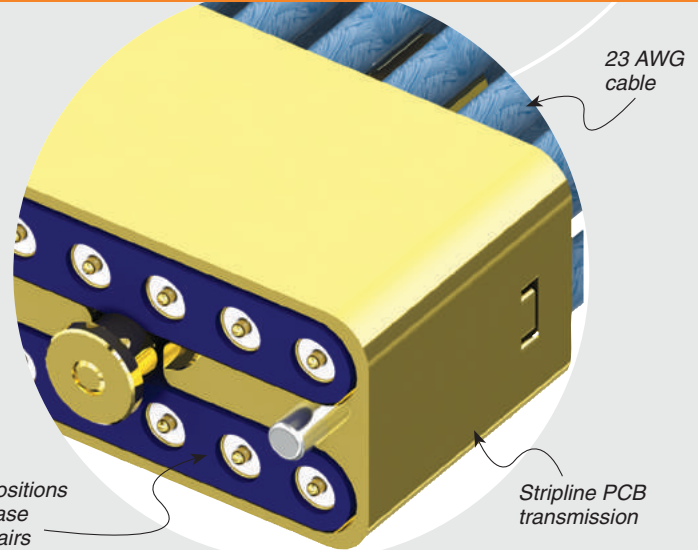

**Specify END 2 OPTION from chart**

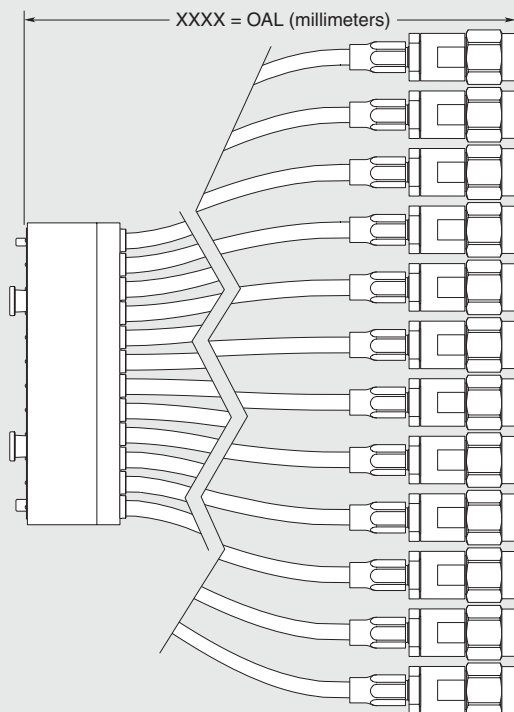

<b>-02</b> = 2.0 Pico-second
<b>-05</b> = 5.0 Pico-second
<b>-10</b> = 10.0 Pico-second

<b>-“XXXX”</b> = Overall Length in millimeters -0100 (100 mm) 3.94" to -9999 (9999 mm) 393.7"
--------------------------------------------------------------------------------------------------------

END 2 OPTIONS	
<b>92SJP = 2.92</b> Straight Jack (30 μ" (0.76 μm) Gold on Center Contact, Stainless Steel on Shell)	
<b>-92SPP = 2.92</b> Straight Plug (30 μ" (0.76 μm) Gold on Center Contact, Stainless Steel on Shell)	

**Patent:** 7544093

**Note:** Some lengths, styles and options are non-standard, non-returnable.

*Due to technical progress, all designs, specifications and components are subject to change without notice.*

[WWW.SAMTEC.COM](http://WWW.SAMTEC.COM)

All parts within this catalog are built to Samtec's specifications. Customer specific requirements must be approved by Samtec and identified in a Samtec customer-specific drawing to apply.



BQRA-92SPP-02-10-0200

**BQRA SERIES**

# 20 GHz QUAD ROW TEST ASSEMBLY

**SPECIFICATIONS**

For complete specifications see [www.samtec.com?BQRA](http://www.samtec.com?BQRA)

**End 2 Connector:**

**Shell Material:** Stainless Steel  
**Contact Material:** BeCu

**Cable Body:** Stainless Steel  
**Insulator Material:** Ultem 1000

**Operating Temperature:** -65 °C to +165 °C

**Impedance:** 50 Ω

**Frequency Range:** 20 GHz

**RoHS Compliant:** Yes

**MWC-2350-01**

**Cable:**

**Cable Type:** Low Loss Microwave Coax

**Gauge:** 23 AWG

**Shield Material:**  
1. Flat silver plated copper  
2. Silver plated copper braid

**Dielectric:** Solid FEP

**Jacket Material:** FEP

**Bend Radius:** 12 mm

**Impedance:** 50 Ω ± 1 Ω

**COMPONENTS**

- For replacement cable see [www.samtec.com?BE23S](http://www.samtec.com?BE23S)
- For replacement block see [www.samtec.com?BQR](http://www.samtec.com?BQR)
- Replacement elastomer gaskets available. Contact Samtec.

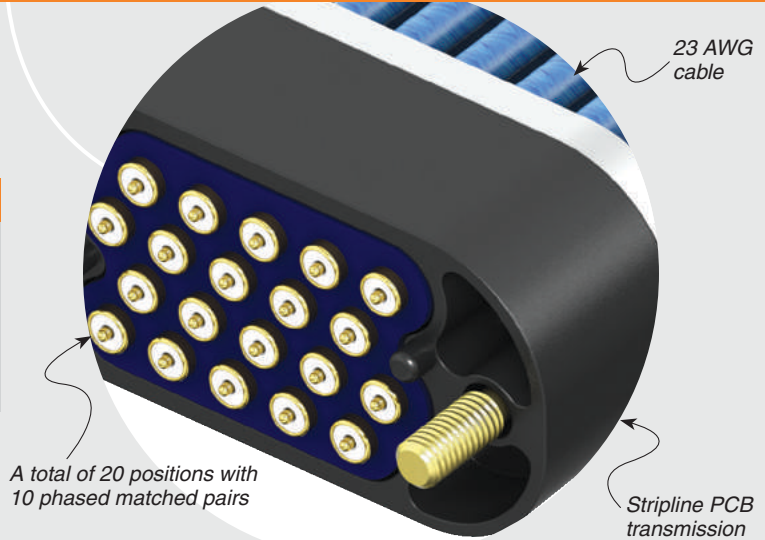

A total of 20 positions with 10 phased matched pairs

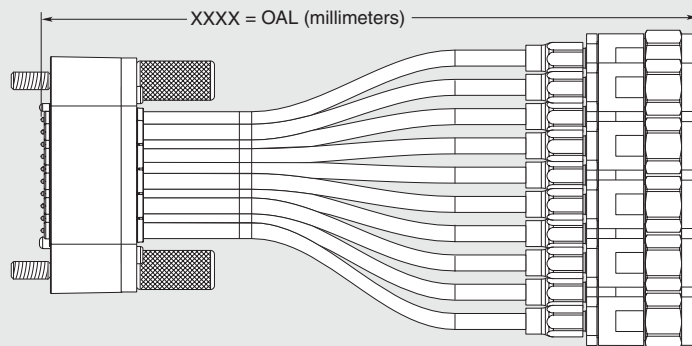
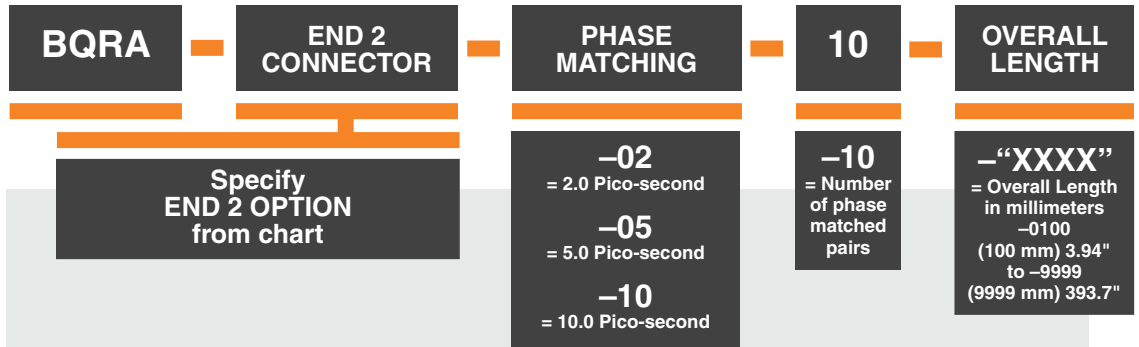

END 2 OPTIONS	
<p><b>92SJP = 2.92 mm</b> Straight Jack (30 μ" (0.76 μm) Gold on Center Contact, Stainless Steel on Shell)</p>	
<p><b>-92SPP = 2.92 mm</b> Straight Plug (30 μ" (0.76 μm) Gold on Center Contact, Stainless Steel on Shell)</p>	

**Patent:** 7544093

**Note:** Some lengths, styles and options are non-standard, non-returnable.

Due to technical progress, all designs, specifications and components are subject to change without notice.

[WWW.SAMTEC.COM](http://WWW.SAMTEC.COM)

All parts within this catalog are built to Samtec's specifications. Customer specific requirements must be approved by Samtec and identified in a Samtec customer-specific drawing to apply.

# REPLACEMENT COMPONENTS

Testing can be a long, arduous process and engineers need an assembly that will stand up to the demands. Yet, even the best components have a life cycle. As a result, Samtec makes it easy to order replacement components for our Bulls Eye® assemblies. The following outlines each replacement component, and in which assembly it is used:

SERIES	COMPONENT	ASSEMBLY USED IN
BE40B	Block	BE40A
BE40C	Cable	BE40A
BDR	Block	BDRA
BQR	Block	BQRA
BE23S	Cable	BDRA and BQRA
	Elastomer	BDRA and BQRA

**BULLSEYE**<sup>®</sup>  
TEST POINT SYSTEM

[samtec.com/BullsEye](http://samtec.com/BullsEye)

To find these replacement components on our website, simply type the series name into the search box in the upper, right-hand corner of [samtec.com](http://samtec.com). Contact [RFTechnicalGroup@samtec.com](mailto:RFTechnicalGroup@samtec.com) for additional information.



## BE40B SERIES | Replacement block for 50 GHz Bulls Eye® (BE40A)

- Microstrip or stripline PCB transmission
- Double row



## BE40C SERIES | Replacement cable for 50 GHz Bulls Eye® (BE40A)

- Pogo-pin design with ground/signal/ground
- 23 AWG solid dielectric low loss cable with additional copper foil shield



## BDR SERIES | Replacement block for 20 GHz Bulls Eye® (BDRA)

- Stripline PCB transmission
- Double row



## BQR SERIES | Replacement block for 20 GHz Bulls Eye® (BDRA)

- Stripline PCB transmission
- Quad row



## BE23S SERIES | Replacement cable for 20 GHz Bulls Eye® (BDRA, BQRA)

- Fixed-pin design
- 23 AWG solid dielectric low loss cable

Due to technical progress, all designs, specifications and components are subject to change without notice.

[WWW.SAMTEC.COM](http://WWW.SAMTEC.COM)

All parts within this catalog are built to Samtec's specifications.

Customer specific requirements must be approved by Samtec and identified in a Samtec customer-specific drawing to apply.



# 50 $\Omega$ & 75 $\Omega$ CABLE ASSEMBLIES

## MICRO HIGH FREQUENCY

50 $\Omega$ RF Cable Assembly, 0.81 mm Diameter (MH081).....	22
50 $\Omega$ RF Cable Assembly, 1.31 mm Diameter (MH113).....	23

## 50 $\Omega$ CABLE ASSEMBLIES

RF Cable Assembly, RG 174 Cable (RF174) .....	24-25
RF Cable Assembly, RG 178 Cable (RF178) .....	26-27
RF Cable Assembly, RG 316 Cable (RF316) .....	28-29
RF Cable Assembly, Double Shielded RG 316 Cable (RS316).....	30
RF Cable Assembly, RG 58 Cable (RF058) .....	31
24 AWG Semi-Flexible RF Cable Assembly, (.086" DIA) (RF405).....	32
19 AWG Semi-Flexible RF Cable Assembly, (.141" DIA) (RF402) .....	33
50 GHz RF Cable Assembly, 23 AWG (RF23C).....	34-35
20 GHz RF Cable Assembly, 23 & 25 AWG (RF23S & RF25S) .....	36

## 75 $\Omega$ CABLE ASSEMBLIES

RF Cable Assembly, RG 6 Cable, 1694A Cable (RFA6T, RFB6T) .....	37
RF Cable Assembly, RG 179 Cable (RF179) .....	38-39
RF Cable Assembly, 1855A Cable (RFB8T).....	40

## APPLICATIONS

50 $\Omega$ Cables & Connectors.....	8-9
75 $\Omega$ Cables & Connectors.....	10-11

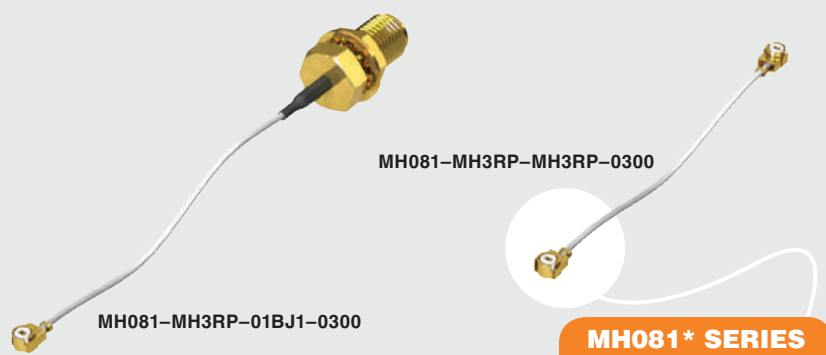

MH081 \* SERIES

# MICRO HIGH FREQUENCY RF CABLES

## SPECIFICATIONS

For complete specifications see [www.samtec.com?MH081](http://www.samtec.com?MH081)

**Outer Contact Material:**  
Au plated Phosphor Bronze  
**Center Contact Material:**  
Au plated Phosphor Bronze (MHX)  
Au plated BeCu (SMA)  
**Insulator Material:**  
PBT (MHX)  
PTFE (SMA)  
**Operating Temperature:**  
-40 °C to +90 °C  
**Voltage Rating:**  
170 V max  
**Dielectric Withstanding Voltage:** 200 Vrms  
**Frequency Range:**  
0-6 GHz  
**Impedance:** 50 Ω  
**RoHS Compliant:** Yes

### 0.81 mm Cable:

**Impedance:**  
50 Ω  
**Capacitance:**  
100 pF/meter  
**Max Attenuation (cable only):**  
3.1 dB @ 1 GHz  
**Conductor Size:**  
36 AWG, (0.81 mm) .032" dia.  
**Conductor Material:**  
Silver Plated Copper  
**Conductor Resistance:**  
1.40 Ω/meter max  
**Insulator Diameter:**  
(0.4 mm) .016"  
**Insulator Material:**  
FEP  
**Shield Material:**  
Silver Plated Copper  
**Jacket Material:**  
PFA  
**Jacket Diameter:**  
(0.81 mm) .032" dia.  
**Bend Radius:**  
5.0 mm  
**Jacket Temp Rating:**  
-40 °C to +90 °C  
**RoHS Compliant:** Yes

## ALSO AVAILABLE (MOQ Required)

- Additional stripping and tinning options
- Additional end connector combinations
- Overall lengths Contact Samtec.

## EXTRACTION TOOLS

- -MH1RP = RSP-122893-01
- -MH3RP = RSP-122893-02

## APPLICATION

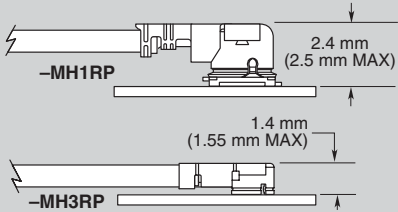

U.F.L and W.F.L Types

Micro High Frequency RF, MHF or SMA Bulkhead

(0.81 mm) .032" Diameter Cable

Mating PCB connectors available

## MATING SOLUTIONS

- Micro RF PCB connectors for Micro High Frequency RFs
- MH1RP end mates with RSP-122811-01 (Cycles: 30 max.)
- MH3RP end mates with RSP-122811-02

MH081

END 1 CONNECTOR

END 2 CONNECTOR

OVERALL LENGTH

Specify END OPTIONS from chart

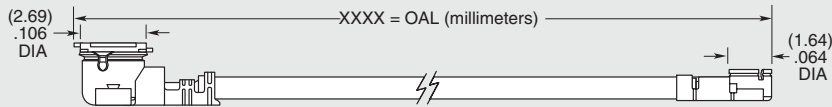

-0030 = 1.18" (30 mm)

-0050 = 1.97" (50 mm)

-0100 = 3.94" (100 mm)

-0150 = 5.91" (150 mm)

-0300 = 11.81" (300 mm)

## END OPTIONS

-MH1RP = MHF1 Type Plug  
(3.9 μ" (.1 μm) Gold on Center Contact, 1.9 μ" (.05 μm) Gold on Shell)

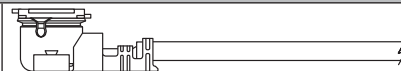

-MH3RP = MHF3 Type Plug  
(3.9 μ" (.1 μm) Gold on Center Contact, 1.9 μ" (.05 μm) Gold on Shell)

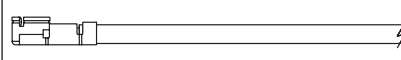

-01BJ1 = SMA Straight Bulkhead Jack

-01BJ2 = SMA Straight Bulkhead Jack, Reversed Polarity

-01SB1 = SMA Straight Jack, Sealed Bulkhead

-01SR1 = SMA Straight Jack, Sealed Bulkhead, Reversed Polarity

(30 μ" (0.76 μm) Gold on Center Contact, Gold Flash on Shell)

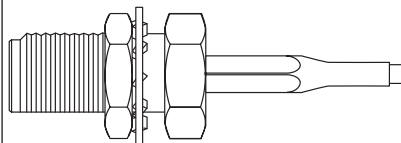

-SING = Single Ended (End 2 callout)

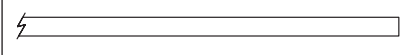

XXXXXX = Stripped & Tinned (End 2 callout)

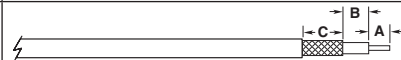

## STRIPPED & TINNED (Dimensions in mm)

CALLOUT	A	B	C
-303030	3.0	3.0	3.0
-303040	3.0	3.0	4.0
-403030	4.0	3.0	3.0
-403040	4.0	3.0	4.0
-404040	4.0	4.0	4.0

Both center conductor and braid shield are stripped, only the center conductor is tinned.

Due to technical progress, all designs, specifications and components are subject to change without notice.

[WWW.SAMTEC.COM](http://WWW.SAMTEC.COM)

All parts within this catalog are built to Samtec's specifications.

Customer specific requirements must be approved by Samtec and identified in a Samtec customer-specific drawing to apply.

\* MH081 Series was previously RF081 Series

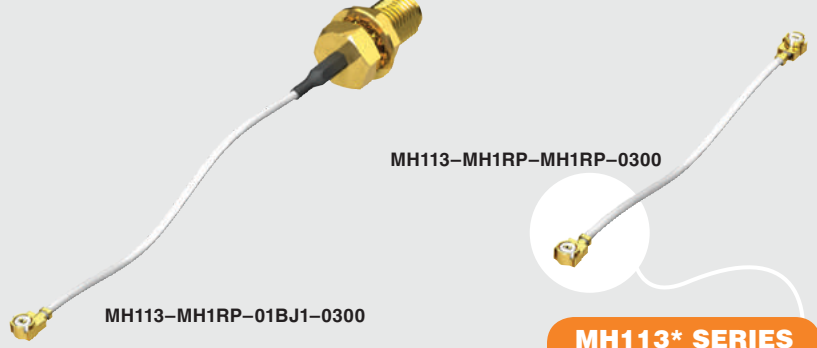

**MH113\* SERIES**

# MICRO HIGH FREQUENCY RF CABLES

**SPECIFICATIONS**

For complete specifications see [www.samtec.com?MH113](http://www.samtec.com?MH113)

- Outer Contact Material:** Au plated Phosphor Bronze
- Center Contact Material:** Au plated Phosphor Bronze (MHX)
- Au plated BeCu (SMA)**
- Insulator Material:** PBT (MHX) PTFE (SMA)
- Operating Temperature:** -40 °C to +90 °C
- Voltage Rating:** 170 V max
- Dielectric Withstanding Voltage:** 200 Vrms
- Frequency Range:** 0-6 GHz
- Impedance:** 50 Ω
- RoHS Compliant:** Yes

- 1.13 mm Cable:**
- Impedance:** 50 Ω
- Capacitance:** 95 pF/meter
- Max Attenuation (cable only):** 2 dB @ 1 GHz
- Conductor Size:** 32 AWG, (1.13 mm) .045" dia.
- Conductor Material:** Silver Plated Copper
- Conductor Resistance:** 0.60 Ω/meter max
- Insulator Diameter:** (0.66 mm) .026"
- Insulator Material:** FEP
- Shield Material:** Tinned Copper
- Jacket Material:** FEP
- Jacket Diameter:** (1.13 mm) .045" dia
- Bend Radius:** 6.8 mm
- Jacket Temp Rating:** -40 °C to +90 °C
- RoHS Compliant:** Yes

**ALSO AVAILABLE (MOQ Required)**

- Additional stripping and tinning options
  - Additional end connector combinations
  - Overall lengths
- Contact Samtec.

**EXTRACTION TOOL**

- -MH1RP = RSP-122893-01

\* MH113 Series was previously RF113 Series

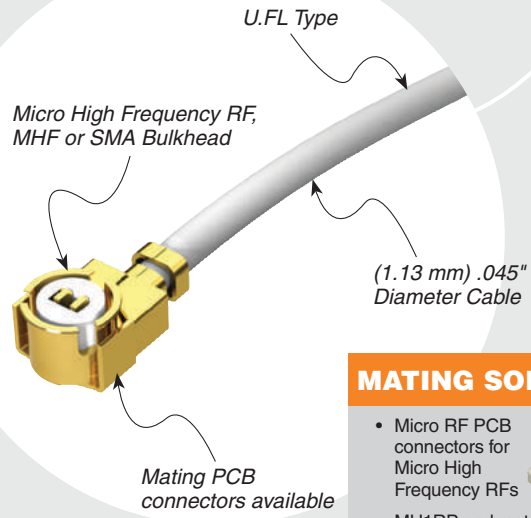

**APPLICATION**

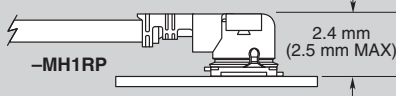

**MATING SOLUTIONS**

- Micro RF PCB connectors for Micro High Frequency RFs
- MH1RP end mates with RSP-122811-01 (Cycles: 30 max.)

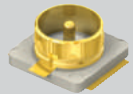

**MH113**

**END 1 CONNECTOR**

**END 2 CONNECTOR**

**OVERALL LENGTH**

Specify END OPTIONS from chart

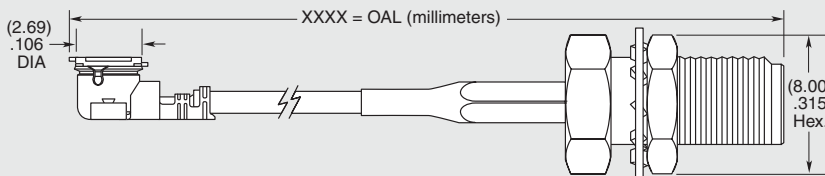

- 0030** = 1.18" (30 mm)
- 0050** = 1.97" (50 mm)
- 0100** = 3.94" (100 mm)
- 0150** = 5.91" (150 mm)
- 0300** = 11.81" (300 mm)

**END OPTIONS**

<p><b>-MH1RP = MHF1 Type Plug</b> (3.9 μ" (.1 μm) Gold on Center Contact, 1.9 μ" (.05 μm) Gold on Shell)</p>	
<p><b>-01BJ1 = SMA Straight Bulkhead Jack</b> <b>-01BJ2 = SMA Straight Bulkhead Jack, Reversed Polarity</b> <b>-01SB1 = SMA Straight Jack, Sealed Bulkhead</b> <b>-01SR1 = SMA Straight Jack, Sealed Bulkhead, Reversed Polarity</b> (30 μ" (0.76 μm) Gold on Center Contact, Gold Flash on Shell)</p>	
<p><b>-SING = Single Ended (End 2 callout)</b></p>	
<p><b>XXXXXX = Stripped &amp; Tinned (End 2 callout)</b></p>	

**STRIPPED & TINNED (Dimensions in mm)**

CALLOUT	A	B	C
-303030	3.0	3.0	3.0
-303040	3.0	3.0	4.0
-403030	4.0	3.0	3.0
-403040	4.0	3.0	4.0
-404040	4.0	4.0	4.0

Both center conductor and braid shield are stripped, only the center conductor is tinned.

Due to technical progress, all designs, specifications and components are subject to change without notice.

RF174-07SP1-01BJ1-0300



RF174-01RP1-02RP1-0200

# 50 Ω RG 174 CABLE ASSEMBLIES

## SPECIFICATIONS

For complete specifications see [www.samtec.com?RF174](http://www.samtec.com?RF174)

### RF Connector:

- Outer Contact Material:** Ni plated Brass (BNC), Au plated Brass (SMB & SMA), Au plated BeCu (MCX & MMCX)
- Center Contact Material:** Au plated Brass (BNC-P, MCX-P, MMCX-P & SMA-P), Au plated BeCu (SMB-P & SMA-J), Au plated Phos. Bronze (BNC-J)
- Insulator Material:** PTFE
- Operating Temperature:** -50 °C to +90 °C
- Impedance:** 50 Ω
- Frequency Range:** 0-6 GHz (Cable & connector dependent)
- RoHS Compliant:** Yes

### RG 174 Cable:

- Impedance:** 50 Ω
- Capacitance:** 101.024 pF/meter
- Max Attenuation (cable only):** 1.4 dB @ 1 GHz for 1 meter
- Conductor Size:** 26 AWG, (0.48 mm) .019" dia.
- Conductor Material:** Copper
- Insulator Material:** KLPE
- Shield Material:** Tin Copper
- Jacket Material:** PVC
- Jacket Diameter:** (2.70 mm) .106"
- Jacket Color:** Black
- Bend Radius:** 25.4 mm
- RoHS Compliant:** Yes

**Mates with:**  
MCX, MMCX, MMCXV,  
SMA, SMB5, BNC5,  
TNC



- Create a full system: cable assembly and board level mates, 50 Ω and 75 Ω solutions
- 24-hour samples on standard products
- Visit: [rf.samtec.com](http://rf.samtec.com)

Standard performance 26 AWG  
RG 174 coax cable

2.3dK

Plugs and  
Jacks

Straight or  
Right-angle

Single or  
Double Ended

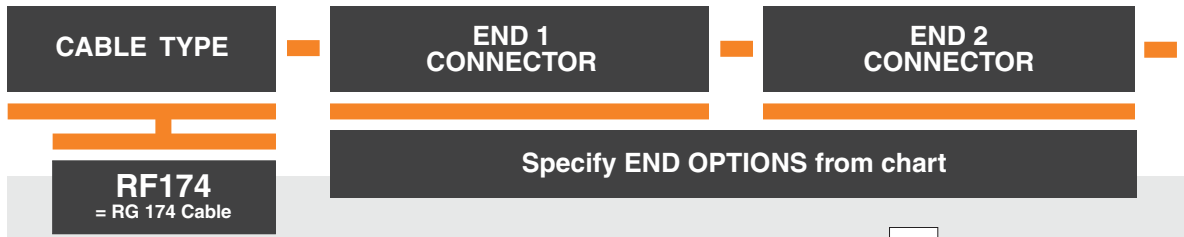

-01SP1-01RP1 SHOWN

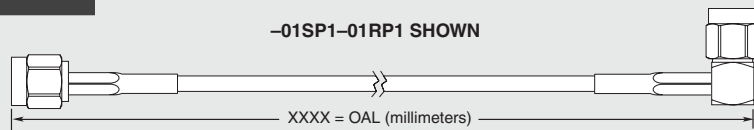

END OPTIONS	
-01SP1 = SMA Straight Plug (30 μ" (0.76 μm) Gold on Center Contact, Gold Flash on Shell)	
-01RP1 = SMA Right-angle Plug (30 μ" (0.76 μm) Gold on Center Contact, Gold Flash on Shell)	
-07SP1 = SMB Straight Plug (30 μ" (0.76 μm) Gold on Center Contact, Gold Flash on Shell)	
-07RP1 = SMB Right-angle Plug (30 μ" (0.76 μm) Gold on Center Contact, Gold Flash on Shell)	
-02SJ1 = MCX Straight Jack (30 μ" (0.76 μm) Gold on Center Contact, Gold Flash on Shell)	

END OPTIONS	
-02RP1 = MCX Right-angle Plug (30 μ" (0.76 μm) Gold on Center Contact, Gold Flash on Shell)	
-02SP1 = MCX Straight Plug (30 μ" (0.76 μm) Gold on Center Contact, Gold Flash on Shell)	
-03SP1 = MMCX Straight Plug (30 μ" (0.76 μm) Gold on Center Contact, Gold Flash on Shell)	
-03RP1 = MMCX Right-angle Plug (30 μ" (0.76 μm) Gold on Center Contact, Gold Flash on Shell)	
-V3SP1 = MMCXV Straight Plug, High Vibration (30 μ" (0.76 μm) Gold on Center Contact, Nickel on Shell)	
-V3RP1 = MMCXV Right-angle Plug, High Vibration (30 μ" (0.76 μm) Gold on Center Contact, Nickel on Shell)	
-V3SJ1 = MMCXV Straight Jack, High Vibration (30 μ" (0.76 μm) Gold on Center Contact, Nickel on Shell)	

Due to technical progress, all designs, specifications and components are subject to change without notice.

[WWW.SAMTEC.COM](http://WWW.SAMTEC.COM)

All parts within this catalog are built to Samtec's specifications. Customer specific requirements must be approved by Samtec and identified in a Samtec customer-specific drawing to apply.





RF174-03RP1-07RP1-0200

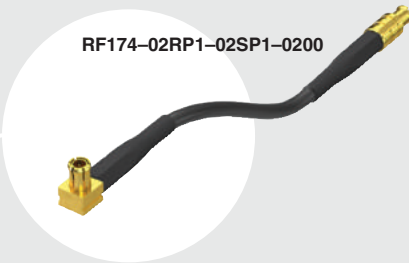

RF174-02RP1-02SP1-0200



RF174-04BJ2-07SP1-0100

**RF174 SERIES**



**ALSO AVAILABLE (MOQ Required)**

- Additional stripping and tinning options
  - IP67 TNC option
  - Additional plating options
  - Additional end connector combinations
  - Knurled nuts with BNC option
- Contact Samtec.



**OTHER SOLUTIONS**

- Cable connector kits (see cable components catalog pages)

**OVERALL LENGTH**

—“XXXX”

= Overall Length in millimeters -0100 (100 mm) minimum  
(Cable lengths larger than 1000 millimeters are not supported by S.I. Test data)

END OPTIONS		END OPTIONS		END OPTIONS																								
<p><b>-04SP3 = BNC</b> Straight Plug (10 μ" (0.25 μm) Gold on Center Contact, Nickel on Shell)</p>		<p><b>-01PN1 = SMA</b> 4-Hole Panel Mount Jack (30 μ" (0.76 μm) Gold on Center Contact, Gold Flash on Shell)</p>		<p><b>-SING = Single Ended</b> (End 2 Callout)</p>																								
<p><b>-05SP3 = TNC</b> Straight Plug (10 μ" (0.25 μm) Gold on Center Contact, Nickel on Shell)</p>		<p><b>-04BJ2 = BNC</b> Bulkhead Jack (30 μ" (0.76 μm) Gold on Center Contact, Nickel on Shell)</p>		<p>XXXXXX = Stripped &amp; Tinned (End 2 Callout)</p>																								
<p><b>-07BJ1 = SMB</b> Bulkhead Jack (30 μ" (0.76 μm) Gold on Center Contact, Gold flash on Shell)</p>		<p><b>-05BJ3 = TNC</b> Bulkhead Jack (10 μ" (0.25 μm) Gold on Center Contact, Nickel on Shell)</p>		<p><b>STRIPPED &amp; TINNED</b> (Dimensions in mm)</p> <table border="1"> <thead> <tr> <th>CALLOUT</th> <th>A</th> <th>B</th> <th>C</th> </tr> </thead> <tbody> <tr> <td>-303030</td> <td>3.0</td> <td>3.0</td> <td>3.0</td> </tr> <tr> <td>-303040</td> <td>3.0</td> <td>3.0</td> <td>4.0</td> </tr> <tr> <td>-403030</td> <td>4.0</td> <td>3.0</td> <td>3.0</td> </tr> <tr> <td>-403040</td> <td>4.0</td> <td>3.0</td> <td>4.0</td> </tr> <tr> <td>-404040</td> <td>4.0</td> <td>4.0</td> <td>4.0</td> </tr> </tbody> </table> <p>Both center conductor and braid shield are stripped, only the center conductor is tinned.</p>	CALLOUT	A	B	C	-303030	3.0	3.0	3.0	-303040	3.0	3.0	4.0	-403030	4.0	3.0	3.0	-403040	4.0	3.0	4.0	-404040	4.0	4.0	4.0
CALLOUT	A	B	C																									
-303030	3.0	3.0	3.0																									
-303040	3.0	3.0	4.0																									
-403030	4.0	3.0	3.0																									
-403040	4.0	3.0	4.0																									
-404040	4.0	4.0	4.0																									
<p><b>-01BJ1 = SMA</b> Straight Bulkhead Jack <b>-01SB1 = SMA</b> Straight Bulkhead Jack, Sealed <b>-01SR1 = SMA</b> Straight Bulkhead Jack, Sealed, Reversed Polarity <b>-01BR1 = SMA</b> Straight Bulkhead Jack, Reversed Polarity (30 μ" (0.76 μm) Gold on Center Contact, Gold Flash on Shell)</p>		<p><b>-06BJ2 = N Type</b> Bulkhead Jack (30 μ" (0.76 μm) Gold on Center Contact, Nickel on Shell)</p>																										

Due to technical progress, all designs, specifications and components are subject to change without notice.

[WWW.SAMTEC.COM](http://WWW.SAMTEC.COM)

All parts within this catalog are built to Samtec's specifications.  
Customer specific requirements must be approved by Samtec and identified in a Samtec customer-specific drawing to apply.

RF178-02RP1-01BJ1-0200

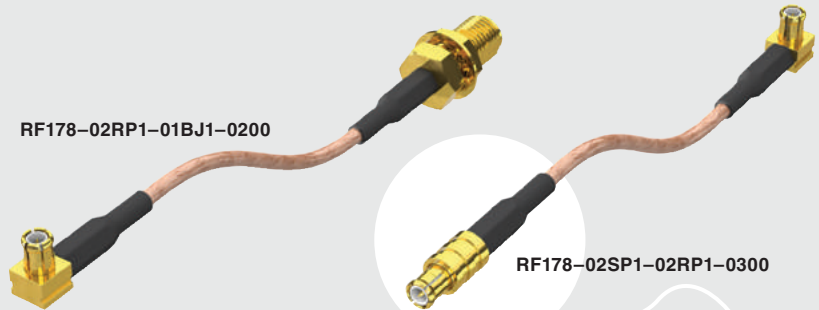

RF178-02SP1-02RP1-0300

# 50 Ω RG 178 CABLE ASSEMBLIES

## SPECIFICATIONS

For complete specifications see [www.samtec.com?RF178](http://www.samtec.com?RF178)

### RF Connector:

**Outer Contact Material:**  
Au plated Brass (SMA & SMB)  
Au plated BeCu (MCX & MMCX)  
Nickel (BNC & TNC)

### Center Contact Material:

Au plated Brass  
(MCX-P, MMCX-P, BNC,  
TNC & SMB)

Au plated BeCu  
(SMA-J & MCX-J)

### Insulator Material:

PTFE

### Operating Temperature:

-50 °C to +165 °C

### Frequency Range:

0-5 GHz  
(Connector dependent)

### Impedance:

50 Ω

### RoHS Compliant:

Yes

### RG 178 Cable:

#### Impedance:

50 Ω

#### Capacitance:

96 pF/meter

#### Propagation Delay:

4.83 nsec/meter

#### Max Attenuation

(cable only):

1.7 dB @ 1 GHz for 1 meter

#### Conductor Size:

30 AWG, (0.31 mm) .012" dia.

#### Conductor Material:

Silver Plated Copper

#### Conductor Resistance:

0.34 Ω/meter max

#### Current Rating:

3 A DC

#### Insulator Diameter:

(0.86 mm) .034"

#### Insulator Material:

PTFE

#### Dielectric Constant:

2.1 dK

#### Shield Material:

Silver Plated Copper Clad Steel

#### Jacket Material:

FEP

#### Jacket Diameter:

(1.80 mm) .071"

#### Jacket Temp Rating:

-50 °C to +165 °C

#### Jacket Color:

Amber

#### Bend Radius:

10.2 mm

#### RoHS Compliant:

Yes

### Mates with:

MCX, MMCX, BNC5,  
TNC, SMA, SMB5



**Solutionator**  
DESIGN IN A MINUTE

- Create a full system: cable assembly and board level mates, 50 Ω and 75 Ω solutions
- 24-hour samples on standard products
- Visit: [rf.samtec.com](http://rf.samtec.com)

Light Gauge 30 AWG  
RG 178 coax cable

2.1dK

Standard Heat  
Shrink

SMA, MCX, MMCX,  
SMB, BNC, TNC and  
N Type End Options

CABLE TYPE

END 1  
CONNECTOR

END 2  
CONNECTOR

**RF178**  
= RG 178 Cable

Specify END OPTIONS from chart

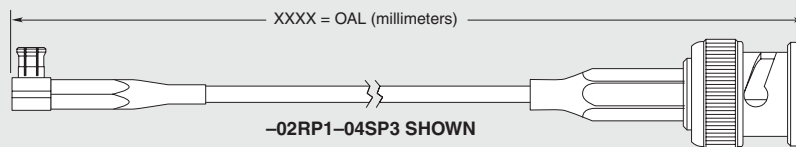

END OPTIONS		END OPTIONS	
<p><b>-01BJ1 = SMA</b> Straight Bulkhead Jack <b>-01BR1 = SMA</b> Straight Bulkhead Jack, Reversed Polarity</p> <p>(30 μ" (0.76 μm) Gold on Center Contact, Gold Flash on Shell)</p>		<p><b>-02SP1 = MCX</b> Straight Plug (30 μ" (0.76 μm) Gold on Center Contact, Gold Flash on Shell)</p>	
<p><b>-02SJ1 = MCX</b> Straight Jack (30 μ" (0.76 μm) Gold on Center Contact, Gold Flash on Shell)</p>		<p><b>-03SP1 = MMCX</b> Straight Plug (30 μ" (0.76 μm) Gold on Center Contact, Gold Flash on Shell)</p>	
<p><b>-02RP1 = MCX</b> Right-angle Plug (30 μ" (0.76 μm) Gold on Center Contact, Gold Flash on Shell)</p>		<p><b>-03RP1 = MMCX</b> Right-angle Plug (30 μ" (0.76 μm) Gold on Center Contact, Gold Flash on Shell)</p>	

Due to technical progress, all designs, specifications and components are subject to change without notice.

[WWW.SAMTEC.COM](http://WWW.SAMTEC.COM)

All parts within this catalog are built to Samtec's specifications.

Customer specific requirements must be approved by Samtec and identified in a Samtec customer-specific drawing to apply.

RF178-04SP3-02SJ1-0100

RF178-01BJ1-03RP1-0200

RF178-07BJ2-03SP1-0200

**RF178 SERIES**

Straight or Right-angle

Variety of Bulkhead Jacks

Single or Double ended

**ALSO AVAILABLE**  
(MOQ Required)

- Additional stripping and tinning options
  - IP67 TNC option
  - Additional plating options
  - Additional end connector combinations
- Contact Samtec.



**OTHER SOLUTIONS**

- Cable connector kits (see cable components catalog pages)

**OVERALL LENGTH**

—“XXXX”

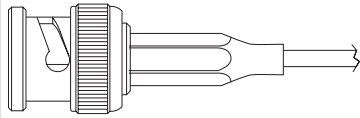
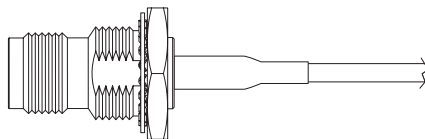
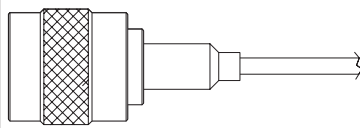
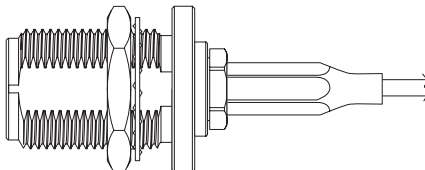
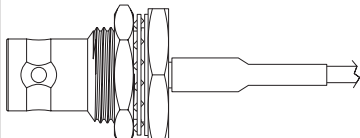
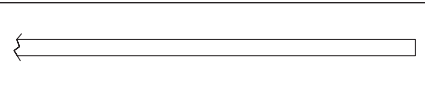
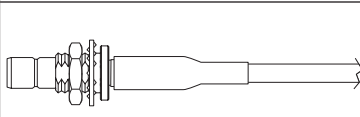
= Overall Length in millimeters -0100 (100 mm) 3.94" minimum

END OPTIONS		END OPTIONS	
<p><b>-04SP3 = BNC</b> Straight Plug (10 μ" (0.25 μm)) Gold on Center Contact, Nickel on Shell</p> 		<p><b>-05BJ3 = TNC</b> Straight Bulkhead Jack (10 μ" (0.25 μm)) Gold on Center Contact, Nickel on Shell</p> 	
<p><b>-05SP3 = TNC</b> Straight Plug (10 μ" (0.25 μm)) Gold on Center Contact, Nickel on Shell</p> 		<p><b>-06BJ2 = N Type</b> Straight Bulkhead Jack (30 μ" (0.76 μm)) Gold on Center Contact, Nickel on Shell</p> 	
<p><b>-04BJ2 = BNC</b> Straight Bulkhead Jack (30 μ" (0.76 μm)) Gold on Center Contact, Nickel on Shell</p> 		<p><b>-SING =</b> Single Ended (End 2 Callout)</p> 	
<p><b>-07BJ2 = SMB</b> Straight Bulkhead Jack (30 μ" (0.76 μm)) Gold on Center Contact, Nickel on Shell</p> 		<p><b>XXXXXX =</b> Stripped &amp; Tinned (End 2 Callout)</p> 	

**STRIPPED & TINNED**  
(Dimensions in mm)

CALLOUT	A	B	C
-303030	3.0	3.0	3.0
-303040	3.0	3.0	4.0
-403030	4.0	3.0	3.0
-403040	4.0	3.0	4.0
-404040	4.0	4.0	4.0

Both center conductor and braid shield are stripped, only the center conductor is tinned.

Due to technical progress, all designs, specifications and components are subject to change without notice.

[WWW.SAMTEC.COM](http://WWW.SAMTEC.COM)

All parts within this catalog are built to Samtec's specifications. Customer specific requirements must be approved by Samtec and identified in a Samtec customer-specific drawing to apply.

RF316-07SP1-01BJ1-0300

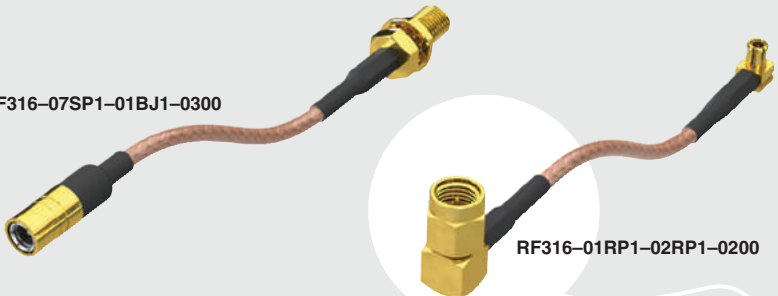

RF316-01RP1-02RP1-0200

# 50 Ω RG 316 CABLE ASSEMBLIES

## SPECIFICATIONS

For complete specifications see [www.samtec.com?RF316](http://www.samtec.com?RF316)

### RF Connector:

#### Outer Contact Material:

Ni plated Brass (BNC)  
Au plated Brass (SMB & SMA)  
Au plated BeCu (MCX & MMCX)

#### Center Contact Material:

Au plated Brass (BNC-P, MCX-P, MMCX-P & SMA-P)  
Au plated BeCu (SMB-P & SMA-J)

#### Insulator Material:

PTFE  
Operating Temperature:

-50 °C to +165 °C

#### Impedance:

50 Ω

#### Frequency Range:

0-6 GHz  
(Cable & connector dependent)

#### RoHS Compliant:

Yes

### RG 316 Cable:

#### Impedance:

50 Ω

#### Capacitance:

96.432 pF/meter

#### Max Attenuation

(cable only):  
1.25 dB @ 1 GHz for 1 meter

#### Conductor Size:

26 AWG, (0.51 mm) .020" dia.

#### Conductor Material:

Silver Plated Copper

#### Insulator Material:

PTFE

#### Shield Material:

Silver Plated Copper Clad Steel

#### Jacket Material:

FEP

#### Jacket Diameter:

(2.54 mm) .100"

#### Jacket Color:

Amber

#### Bend Radius:

12.7 mm

#### RoHS Compliant:

Yes

### Mates with:

MCX, MMCX, MMCXV,  
SMA, SMB5, BNC5, TNC



**Solutionator**  
DESIGN IN A MINUTE

- Create a full system: cable assembly and board level mates, 50 Ω and 75 Ω solutions
- 24-hour samples on standard products
- Visit: [rf.samtec.com](http://rf.samtec.com)

High performance 26 AWG  
RG 316 coax cable

Plugs and  
Jacks

Straight or  
Right-angle

Double shielded  
RG 316 cable  
also available  
(RS316 Series)

CABLE TYPE

END 1  
CONNECTOR

END 2  
CONNECTOR

**RF316**  
= RG 316 Cable,  
Single Braid Shield

Specify END OPTIONS from chart

-01SP1-02RP1 SHOWN

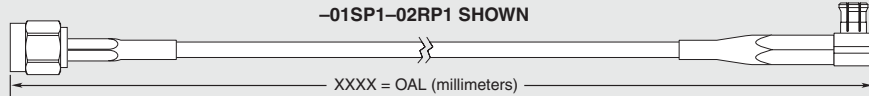

END OPTIONS	
-01SP1 = SMA Straight Plug (30 μ" (0.76 μm) Gold on Center Contact, Gold Flash on Shell)	
-01RP1 = SMA Right-angle Plug (30 μ" (0.76 μm) Gold on Center Contact, Gold Flash on Shell)	
-07SP1 = SMB Straight Plug (30 μ" (0.76 μm) Gold on Center Contact, Gold Flash on Shell)	
-07RP1 = SMB Right-angle Plug (30 μ" (0.76 μm) Gold on Center Contact, Gold Flash on Shell)	
-02SJ1 = MCX Straight Jack (30 μ" (0.76 μm) Gold on Center Contact, Gold Flash on Shell)	

END OPTIONS	
-02RP1 = MCX Right-angle Plug (30 μ" (0.76 μm) Gold on Center Contact, Gold Flash on Shell)	
-02SP1 = MCX Straight Plug (30 μ" (0.76 μm) Gold on Center Contact, Gold Flash on Shell)	
-03SP1 = MMCX Straight Plug (30 μ" (0.76 μm) Gold on Center Contact, Gold Flash on Shell)	
-03RP1 = MMCX Right-angle Plug (30 μ" (0.76 μm) Gold on Center Contact, Gold Flash on Shell)	
-V3SP1 = MMCXV Straight Plug, High Vibration (30 μ" (0.76 μm) Gold on Center Contact, Nickel on Shell)	
-V3RP1 = MMCXV Right-angle Plug, High Vibration (30 μ" (0.76 μm) Gold on Center Contact, Nickel on Shell)	
-V3SJ1 = MMCXV Straight Jack, High Vibration (30 μ" (0.76 μm) Gold on Center Contact, Nickel on Shell)	

## OTHER SOLUTIONS

- Double shielded RG 316 cable available, see RS316 Series
- Cable connector kits (see cable components catalog pages)



RF316-03RP1-07RP1-0200



RF316-02RP1-02SP1-0200



RF316-04BJ2-07SP1-0100

**RF316 SERIES**

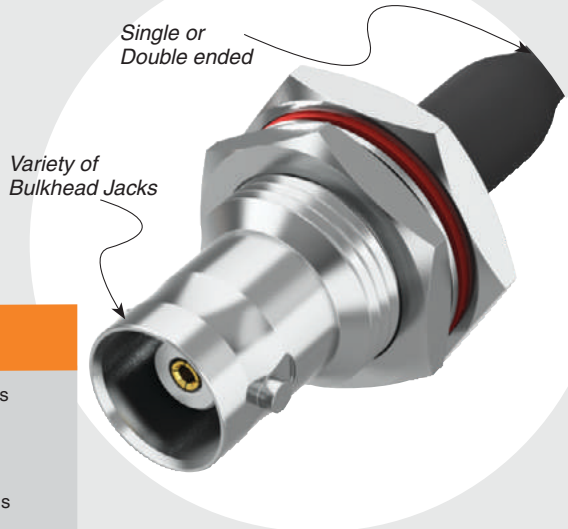
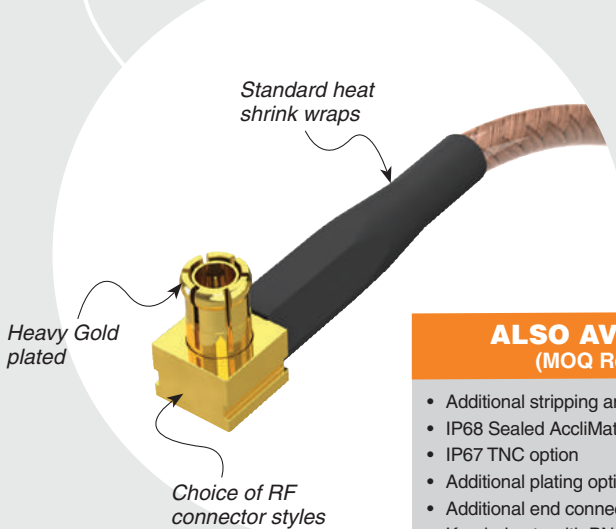

- ALSO AVAILABLE**  
(MOQ Required)
- Additional stripping and tinning options
  - IP68 Sealed AccliMate™ end options
  - IP67 TNC option
  - Additional plating options
  - Additional end connector combinations
  - Knurled nuts with BNC option
- Contact Samtec.

**OVERALL LENGTH**

—“XXXX”

= Overall Length in millimeters -0100 (100 mm) minimum  
(Cable lengths larger than 1000 millimeters are not supported by S.I. Test data)

END OPTIONS		END OPTIONS		END OPTIONS																								
<p>-04SP3 = BNC Straight Plug (10 μ" (0.25 μm) Gold on Center Contact, Nickel on Shell)</p>		<p>-01PN1 = SMA 4-Hole Panel Mount Jack (30 μ" (0.76 μm) Gold on Center Contact, Gold Flash on Shell)</p>		<p>-SING = Single Ended (End 2 Callout)</p>																								
<p>-05SP3 = TNC Straight Plug (10 μ" (0.25 μm) Gold on Center Contact, Nickel on Shell)</p>		<p>-04BJ2 = BNC Bulkhead Jack (30 μ" (0.76 μm) Gold on Center Contact, Nickel on Shell)</p>		<p>XXXXXX = Stripped &amp; Tinned (End 2 Callout)</p>																								
<p>-07BJ1 = SMB Bulkhead Jack (30 μ" (0.76 μm) Gold on Center Contact, Gold Flash on Shell)</p>		<p>-05BJ3 = TNC Bulkhead Jack (10 μ" (0.25 μm) Gold on Center Contact, Nickel on Shell)</p>		<p><b>STRIPPED &amp; TINNED</b> (Dimensions in mm)</p> <table border="1"> <thead> <tr> <th>CALLOUT</th> <th>A</th> <th>B</th> <th>C</th> </tr> </thead> <tbody> <tr> <td>-303030</td> <td>3.0</td> <td>3.0</td> <td>3.0</td> </tr> <tr> <td>-303040</td> <td>3.0</td> <td>3.0</td> <td>4.0</td> </tr> <tr> <td>-403030</td> <td>4.0</td> <td>3.0</td> <td>3.0</td> </tr> <tr> <td>-403040</td> <td>4.0</td> <td>3.0</td> <td>4.0</td> </tr> <tr> <td>-404040</td> <td>4.0</td> <td>4.0</td> <td>4.0</td> </tr> </tbody> </table> <p>Both center conductor and braid shield are stripped, only the center conductor is tinned.</p>	CALLOUT	A	B	C	-303030	3.0	3.0	3.0	-303040	3.0	3.0	4.0	-403030	4.0	3.0	3.0	-403040	4.0	3.0	4.0	-404040	4.0	4.0	4.0
CALLOUT	A	B	C																									
-303030	3.0	3.0	3.0																									
-303040	3.0	3.0	4.0																									
-403030	4.0	3.0	3.0																									
-403040	4.0	3.0	4.0																									
-404040	4.0	4.0	4.0																									
<p>-01BJ1 = SMA Straight Bulkhead Jack -01SB1 = SMA Straight Bulkhead Jack, Sealed -01SR1 = SMA Straight Bulkhead Jack, Sealed, Reversed Polarity -01BR1 = SMA Straight Bulkhead Jack, Reversed Polarity (30 μ" (0.76 μm) Gold on Center Contact, Gold Flash on Shell)</p>		<p>-06BJ2 = N Type Bulkhead Jack (30 μ" (0.76 μm) Gold on Center Contact, Nickel on Shell)</p>																										

Due to technical progress, all designs, specifications and components are subject to change without notice.

[WWW.SAMTEC.COM](http://WWW.SAMTEC.COM)

All parts within this catalog are built to Samtec's specifications.  
Customer specific requirements must be approved by Samtec and identified in a Samtec customer-specific drawing to apply.

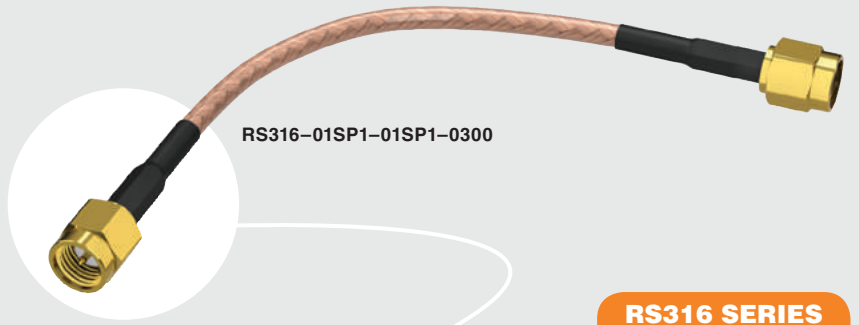

RS316 SERIES

# 50 Ω DOUBLE SHIELDED RG 316 CABLE

## SPECIFICATIONS

For complete specifications see [www.samtec.com?RS316](http://www.samtec.com?RS316)

### RF Connector:

**Outer Contact Material:**  
Ni plated Brass (BNC),  
Au plated Brass (SMA),  
Au plated BeCu (MCX, MMCX)

**Center Contact Material:**  
Au plated Brass  
(SMA, MCX, MMCX),  
Au plated Phosphor Bronze  
(BNC)

**Insulator Material:**  
PTFE

**Operating Temperature:**  
-50 °C to +165 °C

**Impedance:**  
50 Ω

**Frequency Range:**  
0-6 GHz  
(Cable & connector dependent)

**RoHS Compliant:** Yes

### RG 316 DS Cable:

**Impedance:**  
50 Ω

**Capacitance:**  
95.8 pF/meter

**Max Attenuation  
(cable only):**  
1.4 dB @ 2 GHz for 1 meter

**Conductor Size:**  
26 AWG, (0.51 mm) .020" dia.

**Conductor Material:**  
Silver Plated Copper  
Clad Steel

**Insulator Material:** FEP

**Shield 1 Material:** Silver Plated Copper

**Shield 2 Material:** Silver Plated Copper

**Jacket Material:** FEP

**Jacket Diameter:**  
(2.90 mm) .114"

**Jacket Color:** Amber

**Bend Radius:** 12.8 mm

**RoHS Compliant:** Yes

**Mates with:**  
SMA, MCX,  
MMCX, TNC, BNC5



**Solutionator**  
DESIGN IN A MINUTE

- Create a full system: cable assembly and board level mates, 50 Ω and 75 Ω solutions
- 24-hour samples on standard products
- Visit: [rf.samtec.com](http://rf.samtec.com)

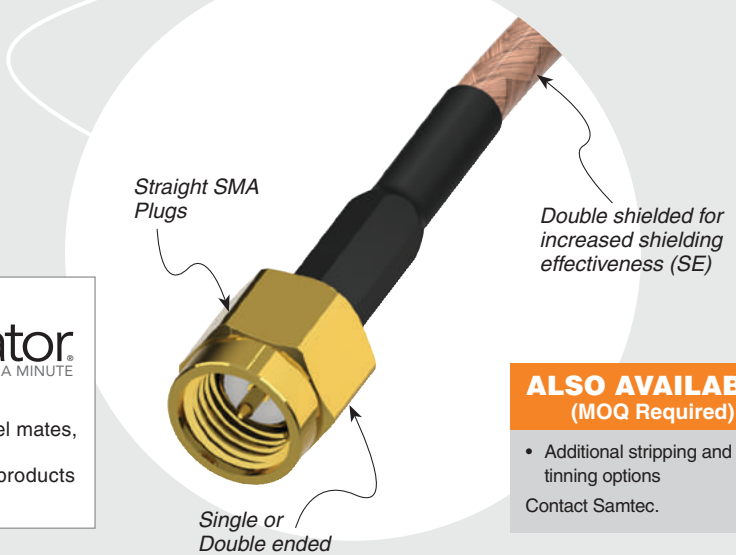

## ALSO AVAILABLE (MOQ Required)

- Additional stripping and tinning options
- Contact Samtec.

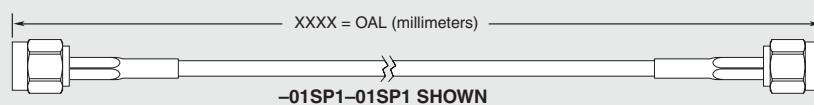

## OTHER SOLUTIONS

- Single shielded RG 316 cable available, see RF316 Series
- Cable connector kits (see cable components catalog pages)

END OPTIONS	
-01SP1 = SMA Straight Plug (30 μ" (0.76 μm) Gold on Center Contact, Gold Flash on Shell)	
02SJ1 = MCX Straight Jack (30 μ" (0.76 μm) Gold on Center Contact, Gold Flash on Shell)	
-02SP1 = MCX Straight Plug (30 μ" (0.76 μm) Gold on Center Contact, Gold Flash on Shell)	
-03SP1 = MMCX Straight Plug (30 μ" (0.76 μm) Gold on Center Contact, Gold Flash on Shell)	
05SP3 = TNC Straight Plug (10 μ" (0.25 μm) Gold on Center Contact, Nickel on Shell)	

END OPTIONS	
-01BJ1 = SMA Straight Bulkhead Jack (30 μ" (0.76 μm) Gold on Center Contact, Gold Flash on Shell)	
-04BJ2 = BNC Bulkhead Jack (30 μ" (0.76 μm) Gold on Center Contact, Nickel on Shell)	
SING = Single Ended (End 2 Callout)	
XXXXXX = Stripped & Tinned (End 2 Callout)	

STRIPPED & TINNED (Dimensions in mm)			
CALLOUT	A	B	C
-303030	3.0	3.0	3.0
-303040	3.0	3.0	4.0
-403030	4.0	3.0	3.0
-403040	4.0	3.0	4.0
-404040	4.0	4.0	4.0

Both center conductor and braid shield are stripped, only the center conductor is tinned.

Due to technical progress, all designs, specifications and components are subject to change without notice.

RF058-01SP1-01SP1-0100



RF058-05SR3-05SR3-0100

**RF058 SERIES**

# 50 Ω RG 58 CABLE ASSEMBLIES

**SPECIFICATIONS**

For complete specifications see [www.samtec.com?RF058](http://www.samtec.com?RF058)

**RF Connector:**

**Outer Contact Material:**  
Ni plated Brass (TNC, N Type),  
Au plated Ni (SMA)

**Center Contact Material:**  
Au plated Ni (TNC, N Type),  
Au plated Brass (SMA)

**Insulator Material:**  
PTFE

**Frequency Range:**  
0~1 GHz

**Impedance:**  
50 Ω

**RoHS Compliant:**  
Yes

**RG 58 Cable:**

**Impedance:**  
50 Ω

**Capacitance:**  
102 pF/meter

**Max Attenuation (cable only):**  
0.8 dB @ 1 GHz

**Conductor Size:**  
20 AWG, (0.90 mm) .036" dia.

**Conductor Material:**  
Tinned Copper

**Insulator Diameter:**  
(3.00 mm) .076"

**Insulator Material:**  
Solid Polyethylene

**Shield Material:**  
Tinned Copper

**Jacket Material:**  
PVC

**Jacket Diameter:**  
(5.00 mm) .197" dia.

**Bend Radius:**  
48.3 mm

**Jacket Temp Rating:**  
-50 °C to +90 °C

**RoHS Compliant:**  
Yes

**Mates with:**  
TNC, SMA



- Create a full system: cable assembly and board level mates, 50 Ω and 75 Ω solutions
- 24-hour samples on standard products
- Visit: [rf.samtec.com](http://rf.samtec.com)

20 AWG  
RG 58 coax cable



Single or Double Ended

SMA, TNC or N Type end options

**RF058**

**END 1 CONNECTOR**

**END 2 CONNECTOR**

**OVERALL LENGTH**

Specify END OPTIONS from chart

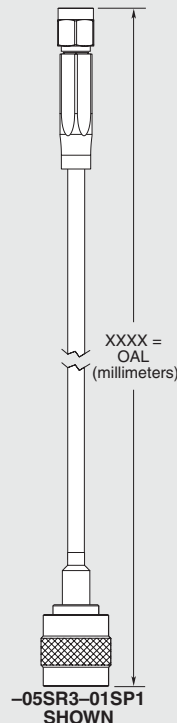

END OPTIONS	
<p><b>-01SP1 = SMA</b> Straight Plug (30 μ" (0.76 μm) Gold on Center Contact, Gold Flash on Outer Contact and Shell)</p>	
<p><b>-05SR3 = TNC</b> Reversed Polarity Straight Plug (10 μ" (0.25 μm) Gold on Center Contact, Nickel on Shell)</p>	
<p><b>-06SP3 = N Type</b> Straight Plug (10 μ" (0.25 μm) Gold on Center Contact, Nickel on Shell)</p>	
<p><b>-01BJ1 = SMA</b> Straight Bulkhead Jack <b>-01SB1 = SMA</b> Straight Bulkhead Jack, Sealed (30 μ" (0.76 μm) Gold on Center Contact, Gold Flash on Outer Contact and Shell)</p>	
<p><b>-SING =</b> Single Ended (End 2 Callout)</p>	
<p><b>-XXXXXX =</b> Stripped &amp; Tinned (End 2 Callout)</p>	

–“XXXX”  
= Overall Length in millimeters  
–0100 (100 mm) 3.94" minimum

**STRIPPED & TINNED (Dimensions in mm)**

CALLOUT	A	B	C
-303030	3.0	3.0	3.0
-303040	3.0	3.0	4.0
-403030	4.0	3.0	3.0
-403040	4.0	3.0	4.0
-404040	4.0	4.0	4.0

Both center conductor and braid shield are stripped, only the center conductor is tinned.

**ALSO AVAILABLE (MOQ Required)**

- Additional stripping and tinning options
  - Additional plating options
  - Additional end connector options
- Contact Samtec.

**OTHER SOLUTIONS**

- Cable connector kits (see cable components catalog pages)

RF405-01SP1-01RP1-0500

RF405-00SJ7-00SJ7-0500

**RF405 SERIES**

# 50 Ω .086" DIA SEMI-FLEXIBLE CABLE

**SPECIFICATIONS**

For complete specifications see [www.samtec.com?RF405](http://www.samtec.com?RF405)

**RF Connector:**

**Shell Material:**  
Brass (SMA),  
Au plated BeCu (SMP)  
**Contact Material:**  
Brass (SMA),  
Au plated BeCu (SMP)  
**Impedance:**  
50 Ω

**Frequency Range:**  
DC to 20 GHz

**Dielectric Withstanding:**  
1,000 Vrms (SMA),  
500 Vrms min (SMP)

**RG 405 (.086")**

**Cable:**

**Impedance:**  
50 Ω microwave  
**Capacitance:**  
104.97 pF/meter  
**Max Attenuation (cable only):**  
0.72 @ 1 GHz for 1 meter  
**Conductor Size:**  
24 AWG (0.56 mm) .022" dia.  
**Conductor Material:**  
Silver plated copper clad steel  
**Insulator Material:**  
PTFE  
**Shield Material:**  
Tinned Copper  
**Bend Radius:**  
3.18 mm  
**RoHS Compliant:**  
Yes

**Mates with:**  
SMA, SMP



**Solutionator**  
DESIGN IN A MINUTE

- Create a full system: cable assembly and board level mates, 50 Ω and 75 Ω solutions
- 24-hour samples on standard products
- Visit: [rf.samtec.com](http://rf.samtec.com)

Hand-formable semi-flexible cable

(2.18 mm) .086" DIA cable

Choice of SMA or SMP terminations

**CABLE TYPE**

**END 1 CONNECTOR**

**END 2 CONNECTOR**

**OVERALL LENGTH**

**RF405**  
= (2.18 mm) .086" DIA  
24 AWG Semi-flexible  
coax cable

Specify  
END OPTIONS  
from chart

– “XXXX”  
= Overall Length in millimeters  
–0100 (100 mm) 3.94" minimum

**ALSO AVAILABLE (MOQ Required)**

- Additional stripping and tinning options Contact Samtec.

**OTHER SOLUTIONS**

- Cable connector kits (see cable components catalog pages)

**Note:**  
Cable lengths longer than (1000 mm) 39.40" are not supported with S.I. test data.

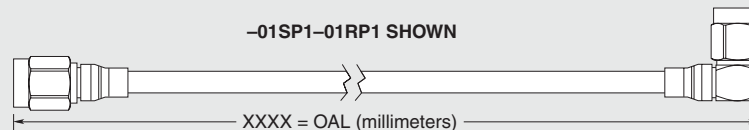

**STRIPPED & TINNED (Dimensions in mm)**

CALLOUT	A	B
-3030	3.0	3.0
-4030	4.0	3.0
-4040	4.0	4.0

Both center conductor and braid shield are stripped, only the center conductor is tinned.

END OPTIONS		END OPTIONS	
<p><b>-01SP1 = SMA</b> Straight Plug (30 μ" (0.76 μm) Gold on Center Contact, Gold Flash on Shell)</p>		<p><b>-00SJ7 = SMP</b> Straight Jack (10 μ" (0.25 μm) Gold on Center Contact, Gold Flash on Shell)</p>	
<p><b>-01RP1 = SMA</b> Right-angle Plug (30 μ" (0.76 μm) Gold on Center Contact, Gold Flash on Shell)</p>		<p><b>-00RJ7 = SMP</b> Right-angle Jack (10 μ" (0.25 μm) Gold on Center Contact, Gold Flash on Shell)</p>	
		<p><b>XXXX = Stripped &amp; Tinned (End 2 callout)</b></p>	

Due to technical progress, all designs, specifications and components are subject to change without notice.

[WWW.SAMTEC.COM](http://WWW.SAMTEC.COM)

All parts within this catalog are built to Samtec's specifications. Customer specific requirements must be approved by Samtec and identified in a Samtec customer-specific drawing to apply.





**RF402 SERIES**

# 50 Ω .141" DIA SEMI-FLEXIBLE CABLE

**SPECIFICATIONS**

For complete specifications see [www.samtec.com?RF402](http://www.samtec.com?RF402)

**RF Connector:**

**Shell Material:**

Brass

**Contact Material:**

Brass

**Insulator Material:**

PTFE

**Impedance:**

50 Ω

**Frequency Range:**

0-20 GHz

**Dielectric Withstanding:**

1,000 Vrms

**RG 402 (.141")**

**Cable:**

**Impedance:**

50 Ω microwave

**Capacitance:**

98.072 pF/meter

**Max Attenuation**

**(cable only):**

0.40 @ 1 GHz for 1 meter

**Conductor Size:**

19 AWG (0.92 mm) .036" dia.

**Conductor Material:**

Silver plated copper clad steel

**Insulator Material:**

PTFE

**Shield Material:**

Tinned Copper

**Bend Radius:**

6.35 mm

**RoHS Compliant:**

Yes

**Mates with:**

SMA



**Solutionator**  
DESIGN IN A MINUTE

- Create a full system: cable assembly and board level mates, 50 Ω and 75 Ω solutions
- 24-hour samples on standard products
- Visit: [rf.samtec.com](http://rf.samtec.com)

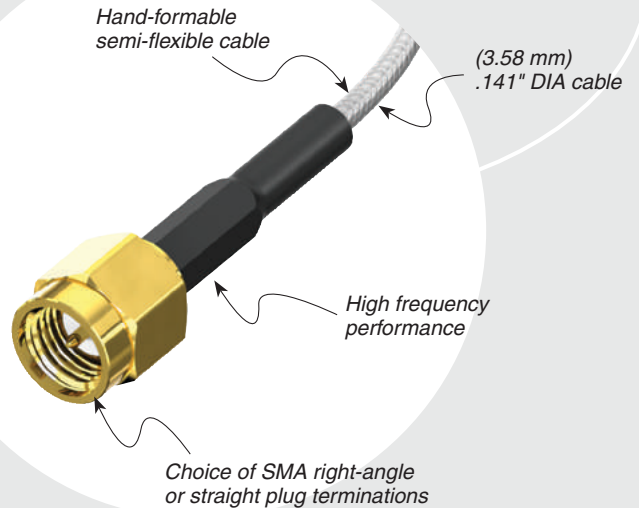

CABLE TYPE	END 1 CONNECTOR	END 2 CONNECTOR	OVERALL LENGTH
<b>RF402</b> = (3.58 mm) .141" DIA 19 AWG Semi-flexible coax cable	Specify END OPTIONS from chart		– “XXXX” = Overall Length in millimeters –0100 (100 mm) 3.94" minimum

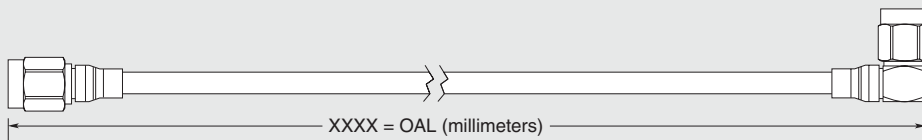

**ALSO AVAILABLE**  
(MOQ Required)

- Additional stripping and tinning options
- Contact Samtec.

**OTHER SOLUTIONS**

- Cable connector kits (see cable components catalog pages)

**Note:**  
Cable lengths longer than (1000 mm) 39.40" are not supported with S.I. test data.

END OPTIONS	
<p>–01SP1 = SMA Straight Plug (30 μ" (0.76 μm) Gold on Center Contact, Gold Flash on Shell)</p>	
<p>–01RP1 = SMA Right-angle Plug (30 μ" (0.76 μm) Gold on Center Contact, Gold Flash on Shell)</p>	
<p><b>XXXX</b> = Stripped &amp; Tinned (End 2 callout)</p>	

**STRIPPED & TINNED**  
(Dimensions in mm)

CALLOUT	A	B
–3030	3.0	3.0
–4030	4.0	3.0
–4040	4.0	4.0

Both center conductor and braid shield are stripped, only the center conductor is tinned.

*Due to technical progress, all designs, specifications and components are subject to change without notice.*

[WWW.SAMTEC.COM](http://WWW.SAMTEC.COM)

All parts within this catalog are built to Samtec's specifications.  
Customer specific requirements must be approved by Samtec and identified in a Samtec customer-specific drawing to apply.

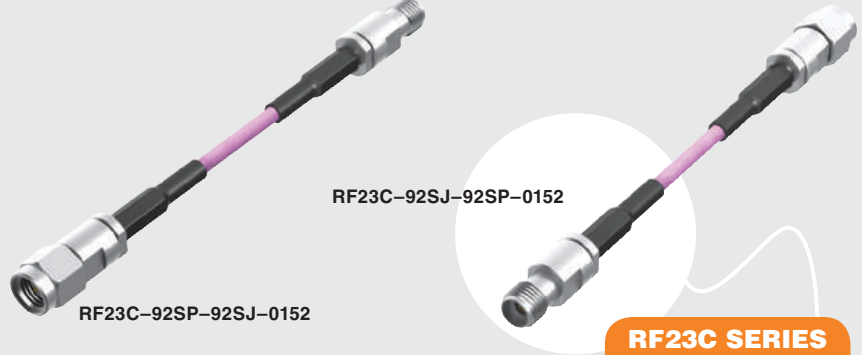

**RF23C SERIES**

# 50 Ω 50 GHz RF CABLE ASSEMBLY

**SPECIFICATIONS**

For complete specifications see [www.samtec.com?RF23C](http://www.samtec.com?RF23C)

**RF Connector:**

**Shell Material:** Stainless Steel  
**Contact Material:** BeCu

**Cable Body:** Stainless Steel

**Insulator Material:** Ultem 1000

**Operating Temperature:** -40 °C to +85 °C

**Impedance:** 50 Ω

**Frequency Range:** 50 GHz

**RoHS Compliant:** Yes

**MWC-2350CU-01 Cable:**

**Type:** Low Loss Microwave Coax

**Gauge:** 23 AWG

**Shield Material:**  
 1. Flat silver plated copper  
 2. Copper tape  
 3. Silver plated copper braid

**Dielectric:** Solid FEP

**Jacket Material:** FEP

**Bend Radius:** 6 mm

**Impedance:** 50 Ω ± 1 Ω

**Propagation Delay:** 4.76 nsec/meter

**Capacitance:** 97.80 pF/meter

**Mates with:** 292

*Robust in dynamic applications*

**TEST REPORTS**

Visit [www.samtec.com?RF23C](http://www.samtec.com?RF23C) or contact [RFTechnicalGroup@samtec.com](mailto:RFTechnicalGroup@samtec.com) for Insertion Loss, Return Loss, V.S.W.R. and other testing information.

*2.92 mm and 2.40 mm terminations*

**APPLICATION**

*Copper foil shielding*

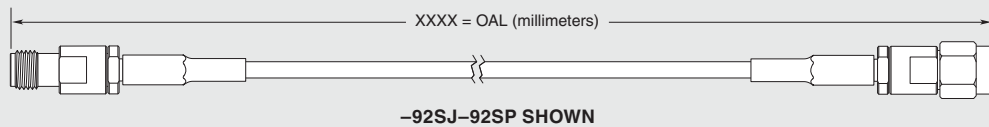
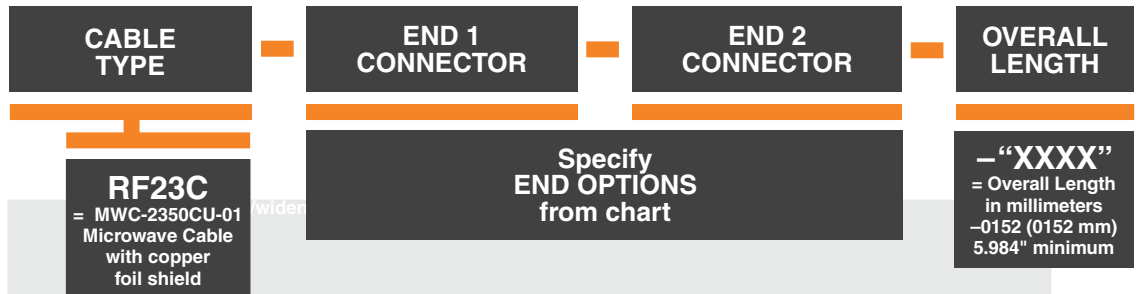
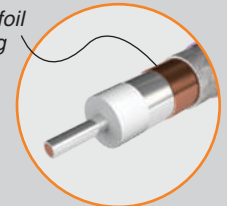

*-24SJ & -24SP PRELIMINARY*

**OTHER SOLUTIONS**

- Bulls Eye® Test Point available
- See [www.samtec.com?BE40C](http://www.samtec.com?BE40C) for complete specifications.

**Notes:**  
 Cable lengths longer than 40.00" (1 meter) are not supported with S.I. test data.

Some lengths, styles and options are non-standard, non-returnable.

END OPTIONS*	
–92SJ = 2.92 mm Straight Jack –24SJ = 2.40 mm Straight Jack (30 μ" (0.76 μm) Gold on Center Contact, Stainless Steel on Shell)	
–92SP = 2.92 mm Straight Plug –24SP = 2.40 mm Straight Plug (30 μ" (0.76 μm) Gold on Center Contact, Stainless Steel on Shell)	

\* 2.40 mm end option is needed for 50 GHz performance. Contact [RFTechnicalGroup@samtec.com](mailto:RFTechnicalGroup@samtec.com)

# 50 Ω, 23 AWG SOLID, MICRO CU COAX CABLE

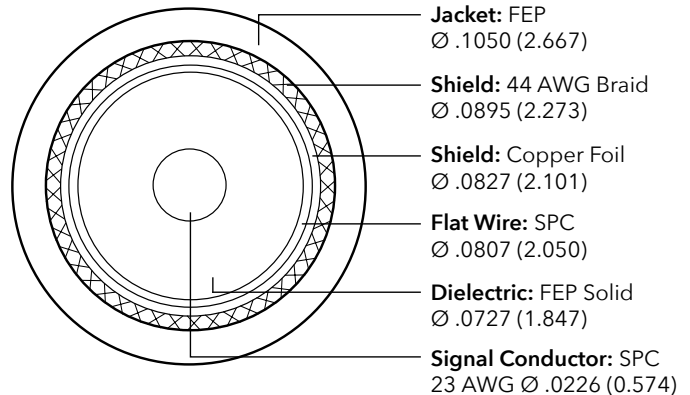
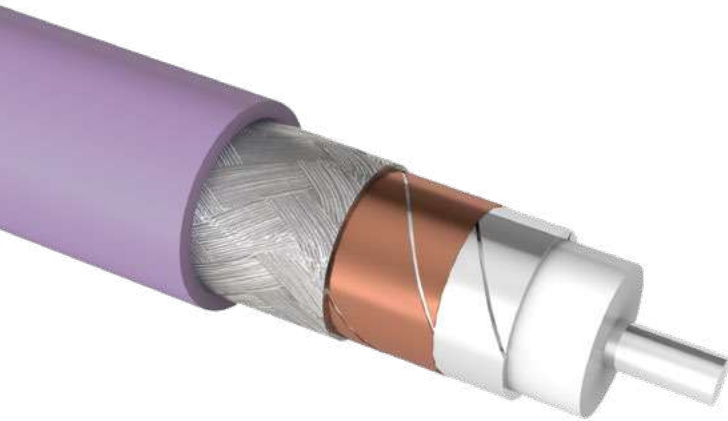

## PERFORMANCE DATA

Capacitance: 97.80 pF/meter (nominal)  
 Propagation Delay: 4.76 ns/meter  
 Flex Cycles: 600 cycles, single conductor\*  
 Current Rating: Single conductor = 6.9 Amps\*\*

Shield DCR: 10.8 Ω/1000 ft  
 CC DCR: 21.6 Ω/1000 ft  
 Min. Bend Radius: 6 mm  
 Availability: Single  
 Temperature Rating: -65 °C to +125 °C, UL VW-1 Tested \*\*\*  
 DWV Working Voltage: 375 V†

Insertion Loss	0.25 m	1 m
-3 dB	>40 GHz	13 GHz
-7 dB	>40 GHz	>40 GHz

\* Test Conditions – 4 oz. weight, dia 7/8" mandrel, +/-90 bend X2

\*\* Rating – 30 °C Temperature Rise, 20% de-rated.

\*\*\* Temperature Rating – Heat Shock/Cold Soak per UL #1581, wire wrap 1/4" mandrel, visual inspection

†Test Conditions – IR/DWW/Thermal Shock/Humidity per EIA-364-20, 21, 31 and 32

## INSERTION LOSS AND RETURN LOSS GRAPHS‡

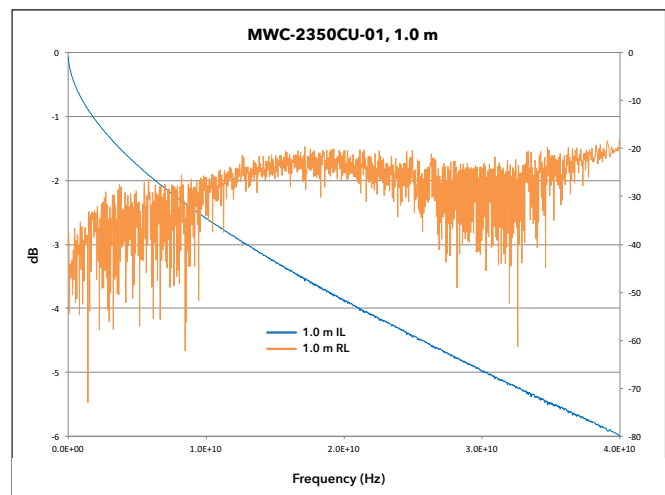
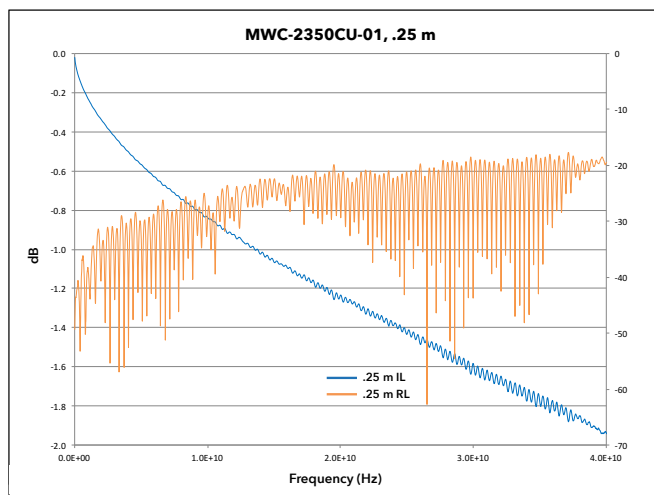

‡IL and RL data is typical. Results may vary. DUT terminated with SMA Connector and has not been de-embedded.



**RF25S, RF23S SERIES**

# 50 Ω RF CABLE ASSEMBLIES

Mates with:  
SMA, SMP

**SPECIFICATIONS**

For complete specifications see [www.samtec.com?RF25S](http://www.samtec.com?RF25S)

**MWC-2550-01**

**Cable:**  
Type: Low Loss Microwave Coax  
Gauge: 25 AWG  
Shield Material:  
1. Flat silver plated copper  
2. Silver plated copper braid  
**Dielectric:** Solid FEP  
**Jacket Material:** FEP  
**Bend Radius:** 9 mm  
**Impedance:** 50 Ω ± 1 Ω  
**Propagation Delay:** 4.76 nsec/meter  
**Capacitance:** 96.8 pF/meter

**Notes:**  
Cable lengths longer than 40.00" (1 meter) are not supported with S.I. test data.  
Some lengths, styles and options are non-standard, non-returnable.

CABLE TYPE	END 1 CONNECTOR	END 2 CONNECTOR	OVERALL LENGTH																																											
<b>RF25S</b> = MWC-2550-01 Microwave Cable with 25 AWG solid FEP Dielectric	Specify END OPTIONS from chart		– "XXXX" = Overall Length in millimeters –0100 (100 mm) 3.94" minimum																																											
<table border="1"> <thead> <tr> <th colspan="2">END OPTIONS</th> </tr> </thead> <tbody> <tr> <td>–01SP1 = SMA Straight Plug (30 μ" (0.76 μm) Gold on Center Contact, Gold Flash on Shell)</td> <td></td> </tr> <tr> <td>–01BJ1 = SMA Bulkhead Jack (30 μ" (0.76 μm) Gold on Center Contact, Gold Flash on Shell)</td> <td></td> </tr> <tr> <td>–00SJ7 = SMP Straight Jack (10 μ" (0.25 μm) Gold on Center Contact, Gold Flash on Shell)</td> <td></td> </tr> </tbody> </table>	END OPTIONS		–01SP1 = SMA Straight Plug (30 μ" (0.76 μm) Gold on Center Contact, Gold Flash on Shell)		–01BJ1 = SMA Bulkhead Jack (30 μ" (0.76 μm) Gold on Center Contact, Gold Flash on Shell)		–00SJ7 = SMP Straight Jack (10 μ" (0.25 μm) Gold on Center Contact, Gold Flash on Shell)		<table border="1"> <thead> <tr> <th colspan="2">END OPTIONS</th> </tr> </thead> <tbody> <tr> <td>–00RJ7 = SMP Right-angle Jack (10 μ" (0.25 μm) Gold on Center Contact, Gold Flash on Shell)</td> <td></td> </tr> <tr> <td>–SING = Single Ended (End 2 only)</td> <td></td> </tr> <tr> <td>XXXXXX = Stripped &amp; Tinned (End 2 only)</td> <td></td> </tr> </tbody> </table>	END OPTIONS		–00RJ7 = SMP Right-angle Jack (10 μ" (0.25 μm) Gold on Center Contact, Gold Flash on Shell)		–SING = Single Ended (End 2 only)		XXXXXX = Stripped & Tinned (End 2 only)		<table border="1"> <thead> <tr> <th colspan="4">STRIPPED &amp; TINNED (Dimensions in mm)</th> </tr> <tr> <th>CALLOUT</th> <th>A</th> <th>B</th> <th>C</th> </tr> </thead> <tbody> <tr> <td>–303030</td> <td>3.0</td> <td>3.0</td> <td>3.0</td> </tr> <tr> <td>–303040</td> <td>3.0</td> <td>3.0</td> <td>4.0</td> </tr> <tr> <td>–403030</td> <td>4.0</td> <td>3.0</td> <td>3.0</td> </tr> <tr> <td>–403040</td> <td>4.0</td> <td>3.0</td> <td>4.0</td> </tr> <tr> <td>–404040</td> <td>4.0</td> <td>4.0</td> <td>4.0</td> </tr> </tbody> </table> <p>Both center conductor and braid shield are stripped, only the center conductor is tinned.</p>	STRIPPED & TINNED (Dimensions in mm)				CALLOUT	A	B	C	–303030	3.0	3.0	3.0	–303040	3.0	3.0	4.0	–403030	4.0	3.0	3.0	–403040	4.0	3.0	4.0	–404040	4.0	4.0	4.0
END OPTIONS																																														
–01SP1 = SMA Straight Plug (30 μ" (0.76 μm) Gold on Center Contact, Gold Flash on Shell)																																														
–01BJ1 = SMA Bulkhead Jack (30 μ" (0.76 μm) Gold on Center Contact, Gold Flash on Shell)																																														
–00SJ7 = SMP Straight Jack (10 μ" (0.25 μm) Gold on Center Contact, Gold Flash on Shell)																																														
END OPTIONS																																														
–00RJ7 = SMP Right-angle Jack (10 μ" (0.25 μm) Gold on Center Contact, Gold Flash on Shell)																																														
–SING = Single Ended (End 2 only)																																														
XXXXXX = Stripped & Tinned (End 2 only)																																														
STRIPPED & TINNED (Dimensions in mm)																																														
CALLOUT	A	B	C																																											
–303030	3.0	3.0	3.0																																											
–303040	3.0	3.0	4.0																																											
–403030	4.0	3.0	3.0																																											
–403040	4.0	3.0	4.0																																											
–404040	4.0	4.0	4.0																																											
<b>ALSO AVAILABLE (MOQ Required)</b>	Additional stripping and tinning options Contact Samtec.		<b>OTHER SOLUTIONS</b>																																											
			Bulls Eye® test point available Contact Samtec.																																											

**SPECIFICATIONS**

For complete specifications see [www.samtec.com?RF23S](http://www.samtec.com?RF23S)

**MWC-2350-01**

**Cable:**  
Type: Low Loss Microwave Coax  
Gauge: 23 AWG  
Shield Material:  
1. Flat silver plated copper  
2. Silver plated copper braid  
**Dielectric:** Solid FEP  
**Jacket Material:** FEP  
**Bend Radius:** 12 mm  
**Impedance:** 50 Ω ± 1 Ω  
**Propagation Delay:** 4.72 nsec/meter  
**Capacitance:** 95.45 pF/meter

**Notes:**  
Cable lengths longer than 40.00" (1 meter) are not supported with S.I. test data.  
Some lengths, styles and options are non-standard, non-returnable.

CABLE TYPE	END 1 CONNECTOR	END 2 CONNECTOR	OVERALL LENGTH																																				
<b>RF23S</b> = MWC-2350-01 Microwave Cable with 23 AWG solid FEP Dielectric	Specify END OPTIONS from chart		– "XXXX" = Overall Length in millimeters –0100 (100 mm) 3.94" minimum																																				
<table border="1"> <thead> <tr> <th colspan="2">END OPTIONS</th> </tr> </thead> <tbody> <tr> <td>–35SJP = 3.50 mm Straight Jack (30 μ" (0.76 μm) Gold on Center Contact, Stainless Steel on Shell)</td> <td></td> </tr> <tr> <td>–35SPP = 3.50 mm Straight Plug (30 μ" (0.76 μm) Gold on Center Contact, Stainless Steel on Shell)</td> <td></td> </tr> <tr> <td>SING = Single Ended (End 2 only)</td> <td></td> </tr> <tr> <td>XXXXXX = Stripped &amp; Tinned (End 2 only)</td> <td></td> </tr> </tbody> </table>	END OPTIONS		–35SJP = 3.50 mm Straight Jack (30 μ" (0.76 μm) Gold on Center Contact, Stainless Steel on Shell)		–35SPP = 3.50 mm Straight Plug (30 μ" (0.76 μm) Gold on Center Contact, Stainless Steel on Shell)		SING = Single Ended (End 2 only)		XXXXXX = Stripped & Tinned (End 2 only)		<table border="1"> <thead> <tr> <th colspan="4">STRIPPED &amp; TINNED (Dimensions in mm)</th> </tr> <tr> <th>CALLOUT</th> <th>A</th> <th>B</th> <th>C</th> </tr> </thead> <tbody> <tr> <td>–303030</td> <td>3.0</td> <td>3.0</td> <td>3.0</td> </tr> <tr> <td>–303040</td> <td>3.0</td> <td>3.0</td> <td>4.0</td> </tr> <tr> <td>–403030</td> <td>4.0</td> <td>3.0</td> <td>3.0</td> </tr> <tr> <td>–403040</td> <td>4.0</td> <td>3.0</td> <td>4.0</td> </tr> <tr> <td>–404040</td> <td>4.0</td> <td>4.0</td> <td>4.0</td> </tr> </tbody> </table> <p>Both center conductor and braid shield are stripped, only the center conductor is tinned.</p>	STRIPPED & TINNED (Dimensions in mm)				CALLOUT	A	B	C	–303030	3.0	3.0	3.0	–303040	3.0	3.0	4.0	–403030	4.0	3.0	3.0	–403040	4.0	3.0	4.0	–404040	4.0	4.0	4.0
END OPTIONS																																							
–35SJP = 3.50 mm Straight Jack (30 μ" (0.76 μm) Gold on Center Contact, Stainless Steel on Shell)																																							
–35SPP = 3.50 mm Straight Plug (30 μ" (0.76 μm) Gold on Center Contact, Stainless Steel on Shell)																																							
SING = Single Ended (End 2 only)																																							
XXXXXX = Stripped & Tinned (End 2 only)																																							
STRIPPED & TINNED (Dimensions in mm)																																							
CALLOUT	A	B	C																																				
–303030	3.0	3.0	3.0																																				
–303040	3.0	3.0	4.0																																				
–403030	4.0	3.0	3.0																																				
–403040	4.0	3.0	4.0																																				
–404040	4.0	4.0	4.0																																				

Due to technical progress, all designs, specifications and components are subject to change without notice.



RFA6T-74SP3-74SP3-0300

RFA6T, RFB6T SERIES

# 75 Ω OPTIMIZED BNC CABLE ASSEMBLIES

## SPECIFICATIONS

For complete specifications see [www.samtec.com?RFA6T](http://www.samtec.com?RFA6T) or [www.samtec.com?RFB6T](http://www.samtec.com?RFB6T)

### RF Connector:

**Outer Contact Material:**  
Ni plated Brass (BNC),  
Au plated BeCu (DIN),  
Au plated Phosphor Bronze (HDBNC)

**Center Contact Material:**  
Gold plated Brass

**Insulator Material:**  
PTFE

**Operating Temperature:**  
-65 °C to +125 °C

**Impedance:**  
75 Ω ± 3 Ω (-ST)  
75 Ω ± 4 Ω (-RA)

**Frequency Range:**  
0-3.5 GHz \*

**Working Voltage:**  
500 Vrms max \*

**Dielectric Withstanding:**  
1500 Vrms min\*

**RoHS Compliant:**  
Yes

### RG 6/1694A Cable:

**Impedance:**  
75 Ω ± 3 Ω

**Capacitance:**  
54 ± 3 pF/meter

**Max Attenuation (cable only):**  
0.21 dB @ 1 GHz for 1 meter

**Conductor Size:**  
18 AWG, (1.02 mm) .040" dia.

**Conductor Material:**  
Bare Copper

**Insulator Material:**  
Gas Injected Foamed Polyethylene

**Shield Material:**  
Tinned Copper Braid over Aluminum Foil Wrap

**Jacket Material:**  
PVC

**Jacket Diameter:**  
(7.00 mm) .275"

**Bend Radius:** 69.85 mm

**Jacket Color:** Black

**RoHS Compliant:** Yes

**Mates with:**  
BNC7T, DIN7A, HDBNC

18 AWG 75 Ω  
RG 6 coax cable,  
or 1694A Belden cable



**Solutionator**  
DESIGN IN A MINUTE

- Create a full system: cable assembly and board level mates, 50 Ω and 75 Ω solutions
- 24-hour samples on standard products
- Visit: [rf.samtec.com](http://rf.samtec.com)

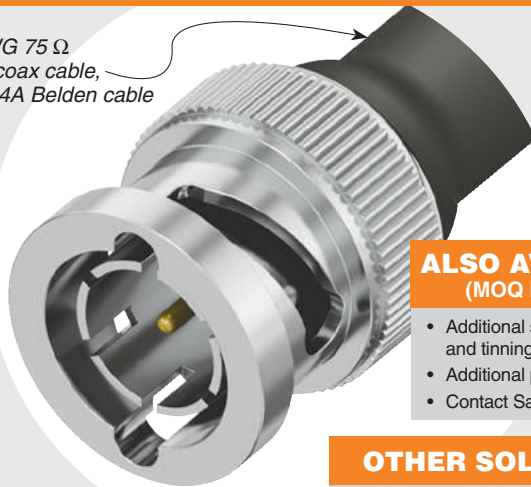

**ALSO AVAILABLE (MOQ Required)**

- Additional stripping and tinning options
- Additional plating options
- Contact Samtec.

## OTHER SOLUTIONS

- Hand tool available. Contact [RFGroup@samtec.com](mailto:RFGroup@samtec.com)
- Cable connector kits (see cable components catalog pages)

\* See connector component pages for specific range.

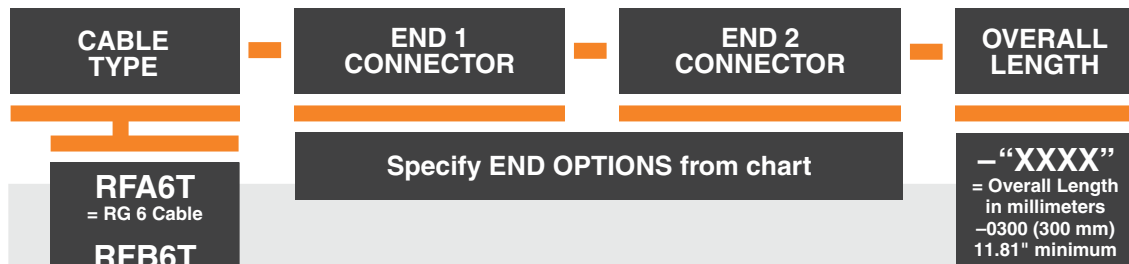

**RFA6T**  
= RG 6 Cable

**RFB6T**  
= Belden 1694A Cable

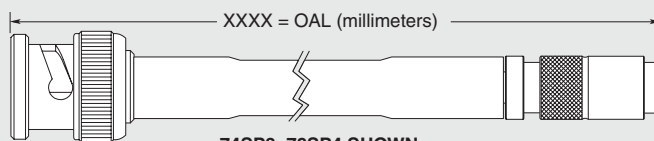

### STRIPPED & TINNED (Dimensions in mm)

CALLOUT	A	B	C
-303030	3.0	3.0	3.0
-303040	3.0	3.0	4.0
-403030	4.0	3.0	3.0
-403040	4.0	3.0	4.0
-404040	4.0	4.0	4.0

Both center conductor and braid shield are stripped, only the center conductor is tinned.

END OPTIONS		END OPTIONS	
-H4SP3 = 75 Ω High-Density BNC Straight Plug (10 μ" (0.25 μm) Gold on Center Contact, Nickel on Shell)		-74RP3 = 75 Ω BNC Right-angle Plug (10 μ" (0.25 μm) Gold on Center Contact, Nickel on Shell)	
-78SP4 = 75 Ω DIN Straight Plug (10 μ" (0.25 μm) Gold on Center Contact, Nickel on Shell)		-SING = Single Ended (End 2 callout)	
-74SP3* = 75 Ω BNC Straight Plug (10 μ" (0.25 μm) Gold on Center Contact, Nickel on Shell)		-XXXXXX = Stripped & Tinned (End 2 callout) (See chart for callout)	

(\*Die Cast also available = -D4SP3)

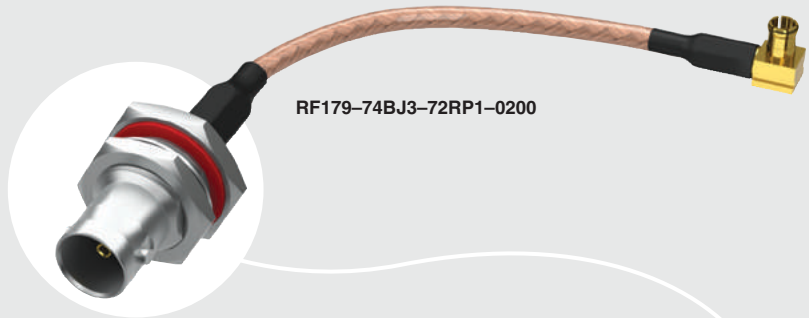

RF179-74BJ3-72RP1-0200

# 75 Ω OPTIMIZED RG 179 CABLES

## SPECIFICATIONS

For complete specifications see [www.samtec.com?RF179](http://www.samtec.com?RF179)

### RF Connector:

#### Outer Contact Material:

Ni plated Brass

(BNC)

Au plated Brass

(SMB)

Au plated BeCu

(MCX, MMCX7, DIN)

#### Center Contact Material:

Au plated Brass

(BNC-P, MCX, MMCX7)

Au plated BeCu

(SMB)

Au plated Copper Alloy

(DIN, BNC-J)

#### Insulator Material:

PTFE

#### Operating Temperature:

-50 °C to +165 °C

#### Impedance:

75 Ω

#### Frequency Range:

0-4 GHz \*

(Cable & connector dependent)

#### RoHS Compliant:

Yes

### RG 179 Cable:

#### Impedance:

75 Ω ±3 Ω

#### Capacitance:

64 pF/meter

#### Propagation Delay:

4.83 nsec/meter

#### Max Attenuation

(cable only):

0.8 dB @ 1 GHz for 1 meter

#### Conductor Size:

30 AWG, (0.31 mm) .012" dia.

#### Conductor Material:

Silver Plated Copper

#### Conductor Resistance:

0.34 Ω/meter max

#### Current Rating:

3 A DC

#### Insulator Diameter:

(1.6 mm) .063"

#### Insulator Material:

PTFE

#### Dielectric Constant:

1.8 dK

#### Shield Material:

Silver Plated Copper

#### Jacket Material:

FEP

#### Jacket Diameter:

(2.54 mm) .100"

#### Bend Radius:

10.2 mm

#### Jacket Temp Rating:

-50 °C to +165 °C

#### Jacket Color:

Amber

#### RoHS Compliant:

Yes

### Mates with:

BNC7T, MCX7, MMCX7,  
SMB7H, DIN7A



**Solutionator**  
DESIGN IN A MINUTE

- Create a full system: cable assembly and board level mates, 50 Ω and 75 Ω solutions
- 24-hour samples on standard products
- Visit: [rf.samtec.com](http://rf.samtec.com)

\* See connector component pages for specific range.

30 AWG  
75 Ω RG 179  
coax cable

Standard  
Heat Shrink

Single or Double  
Ended

CABLE TYPE

END 1  
CONNECTOR

END 2  
CONNECTOR

**RF179**  
= RG 179 Cable

Specify END OPTIONS from chart

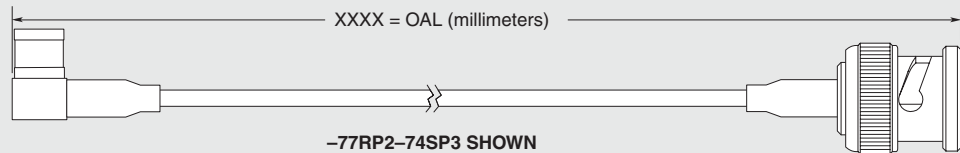

END OPTIONS		END OPTIONS	
<p><b>-73SP4 = 75 Ω MMCX7</b> Straight Plug (10 μ" (0.25 μm) Gold on Center Contact, Gold Flash on Shell)</p>		<p><b>-72RP1 = 75 Ω MCX</b> Right-angle Plug (30 μ" (0.76 μm) Gold on Center Contact, Gold Flash on Shell)</p>	
<p><b>-73RP1 = 75 Ω MMCX7</b> Right-angle Plug (30 μ" (0.76 μm) Gold on Center Contact, Gold Flash on Shell)</p>		<p><b>-72SP1 = 75 Ω MCX</b> Straight Plug (30 μ" (0.76 μm) Gold on Center Contact, Gold Flash on Shell)</p>	
<p><b>-73SJ4 = 75 Ω MMCX7</b> Straight Jack (10 μ" (0.25 μm) Gold on Center Contact, Gold Flash on Shell)</p>		<p><b>-77SP1 = 75 Ω SMB</b> Straight Plug (30 μ" (0.76 μm) Gold on Center Contact, Gold Flash on Shell)</p>	

Due to technical progress, all designs, specifications and components are subject to change without notice.

[WWW.SAMTEC.COM](http://WWW.SAMTEC.COM)

All parts within this catalog are built to Samtec's specifications.

Customer specific requirements must be approved by Samtec and identified in a Samtec customer-specific drawing to apply.



RF179-78SP4-77SP1-0200



RF179-72SP1-73SJ4-0100

**RF179 SERIES**



Wide variety of 75 Ω end options including BNC, MCX and SMB

Straight or Right-angle terminations



**ALSO AVAILABLE**  
(MOQ Required)

- Additional stripping and tinning options
  - Additional plating options
  - Additional end connector combinations
- Contact Samtec.

**OTHER SOLUTIONS**

- Cable connector kits (see cable components catalog pages)

**OVERALL LENGTH**

–“XXXX”

= Overall Length in millimeters –0100 (100 mm) 3.94" minimum

**STRIPPED & TINNED**  
(Dimensions in mm)

CALLOUT	A	B	C
–303030	3.0	3.0	3.0
–303040	3.0	3.0	4.0
–403030	4.0	3.0	3.0
–403040	4.0	3.0	4.0
–404040	4.0	4.0	4.0

Both center conductor and braid shield are stripped, only the center conductor is tinned.

**END OPTIONS**

<p>–77RP1 = 75 Ω SMB Right-angle Plug (30 μ" (0.76 μm) Gold on Center Contact, Gold Flash on Shell)</p>	
<p>–74SP3 = 75 Ω BNC Straight Plug –D4SP3 = 75 Ω BNC Die Cast Straight Plug (10 μ" (0.25 μm) Gold on Center Contact, Nickel on Shell)</p>	
<p>–74BJ3 = 75 Ω BNC Bulkhead Jack (10 μ" (0.25 μm) Gold on Center Contact, Nickel on Shell)</p>	

**END OPTIONS**

<p>–78SP4 = 75 Ω DIN Straight Plug (10 μ" (0.25 μm) Gold on Center Contact, Nickel on Shell)</p>	
<p>–SING = Single Ended (End 2 callout)</p>	
<p>XXXXXX = Stripped &amp; Tinned (End 2 callout)</p>	

Due to technical progress, all designs, specifications and components are subject to change without notice.

[WWW.SAMTEC.COM](http://WWW.SAMTEC.COM)

All parts within this catalog are built to Samtec's specifications.  
Customer specific requirements must be approved by Samtec and identified in a Samtec customer-specific drawing to apply.



RFB8T SERIES

# 75 Ω OPTIMIZED 1855A CABLE ASSEMBLIES

## SPECIFICATIONS

For complete specifications see [www.samtec.com?RFB8T](http://www.samtec.com?RFB8T)

### RF Connector:

**Outer Contact Material:**

Ni plated Brass (BNC)

Au plated BeCu (DIN)

**Center Contact Material:**

Au plated Brass

**Operating Temperature:**

-65 °C to +125 °C

**Impedance:**

75 Ω ±2 Ω (ST), 75 Ω ±4 Ω (RA)

**Frequency Range:**

0-3.5 GHz \*

**Working Voltage:**

250 Vrms (DIN),

330 Vrms (BNC)

**Dielectric Withstanding:**

750 Vrms (DIN),

1000 Vrms (BNC)

**RoHS Compliant:**

Yes

### 1855A Cable:

**Impedance:**

75 Ω ±3 Ω

**Capacitance:**

56 ±3 pF/meter

**Max Attenuation**

(cable only):

0.37 dB @ 1 GHz for 1 meter

**Conductor Size:**

23 AWG, (0.58 mm) .023" dia.

**Conductor Material:**

Bare Copper

**Insulator Material:**

Gas Injected Foamed

Polyethylene

**Shield Material:**

Tin Copper

**Jacket Material:**

PVC

**Jacket Diameter:**

(4.03 mm) .159"

**Bend Radius:**

38.1 mm

**Jacket Color:**

Black

**RoHS Compliant:**

Yes

Mates with:

DIN7A, HDBNC



**Solutionator**  
DESIGN IN A MINUTE

- Create a full system: cable assembly and board level mates, 50 Ω and 75 Ω solutions
- 24-hour samples on standard products
- Visit: [rf.samtec.com](http://rf.samtec.com)

23 AWG 75 Ω  
1855A Belden cable



Single or Double Ended

\* See connector component pages for specific range.

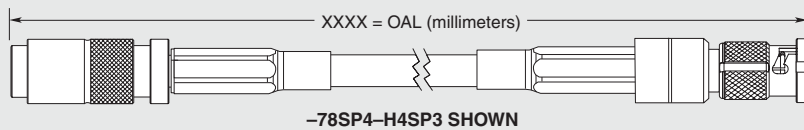
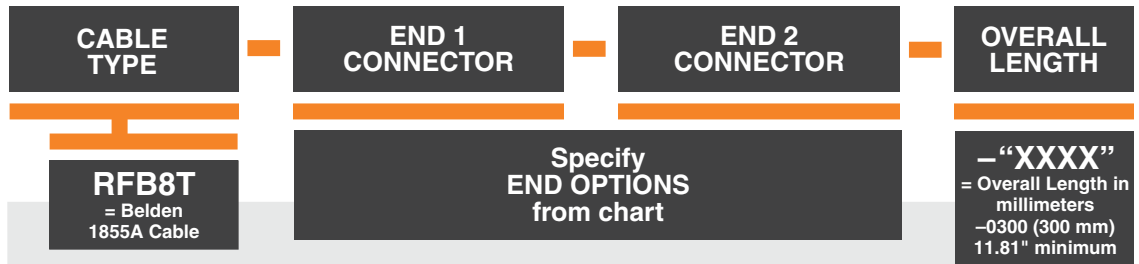

STRIPPED & TINNED (Dimensions in mm)

CALLOUT	A	B	C
-303030	3.0	3.0	3.0
-303040	3.0	3.0	4.0
-403030	4.0	3.0	3.0
-403040	4.0	3.0	4.0
-404040	4.0	4.0	4.0

Both center conductor and braid shield are stripped, only the center conductor is tinned.

## ALSO AVAILABLE (MOQ Required)

- Additional stripping and tinning options
  - Additional plating options
- Contact Samtec.

## OTHER SOLUTIONS

- Hand tool available. Contact [RFGroup@samtec.com](mailto:RFGroup@samtec.com)
- Cable connector kits (see cable components catalog pages)

END OPTIONS	
-H4SP3 = 75 Ω High-Density BNC Straight Plug (10 μ" (0.25 μm) Gold on Center Contact, Nickel on Shell)	
-78SP4 = 75 Ω DIN Straight Plug (10 μ" (0.25 μm) Gold on Center Contact, Nickel on Shell)	

END OPTIONS	
-SING = Single Ended (End 2 callout)	
-XXXXXX = Stripped & Tinned (End 2 callout) (See chart for callout)	





# 50 $\Omega$ & 75 $\Omega$ CONNECTORS

## 50 $\Omega$ CONNECTORS

2.92 mm Precision Jacks & Cable Components (292, 292-CA).....	42-43
50 $\Omega$ SMA Jacks & Cable Components (SMA, SMA-CA) .....	44-46
50 $\Omega$ SMP Jacks/Plugs & Adaptor (SMP, SMP-CA) .....	47
50 $\Omega$ SMB Jacks & Plugs (SMB5, SMB5-CA).....	48
50 $\Omega$ MMCX & MCX Jacks & Plugs (MMCX, MCX) .....	49-50
50 $\Omega$ MMCX & MCX Cable Components (MMCX-CA, MCX-CA) .....	51
50 $\Omega$ BNC Cable Components (BNC5-CA) .....	52
50 $\Omega$ N Type Cable Components (NTPE-CA) .....	53
50 $\Omega$ TNC Jacks & Cable Components (TNC, TNC-CA) .....	54

## 75 $\Omega$ CONNECTORS

75 $\Omega$ DIN 1.0/2.3 Jacks & Cable Components (DIN7A, DIN7A-CA).....	55
75 $\Omega$ High Density BNC Jacks & Cable Components (HDBNC, HDBNC-CA) .....	56-57
75 $\Omega$ BNC Jacks & Cable Components (BNC7T, BNC7T-CA) .....	58-59
75 $\Omega$ SMB Jacks & Cable Components (SMB7H, SMB7H-CA).....	60

## APPLICATIONS

50 $\Omega$ Cables & Connectors.....	8-9
75 $\Omega$ Cables & Connectors.....	10-11

292-J-P-HP-ST-CM2



292-J-P-HP-ST-CM2



**292-CM SERIES**

# 50 Ω 2.92 JACK

**SPECIFICATIONS**

For complete specifications and assembly instructions see [www.samtec.com?292-CM](http://www.samtec.com?292-CM)

- Shell Material:** Stainless Steel
- Insert:** Stainless Steel
- Socket:** BeCu
- Insulator Material:** PCTFE
- Impedance:** 50 Ω
- RoHS Compliant:** Yes
- Lead-Free Solderable:** Yes

**APPLICATION**

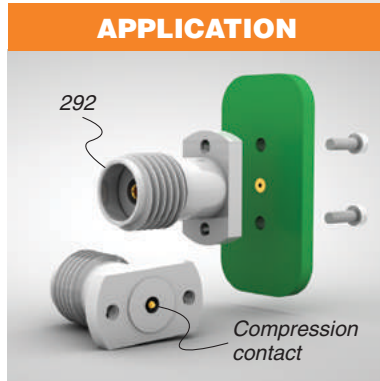

Performance up to 40 GHz/80 Gbps

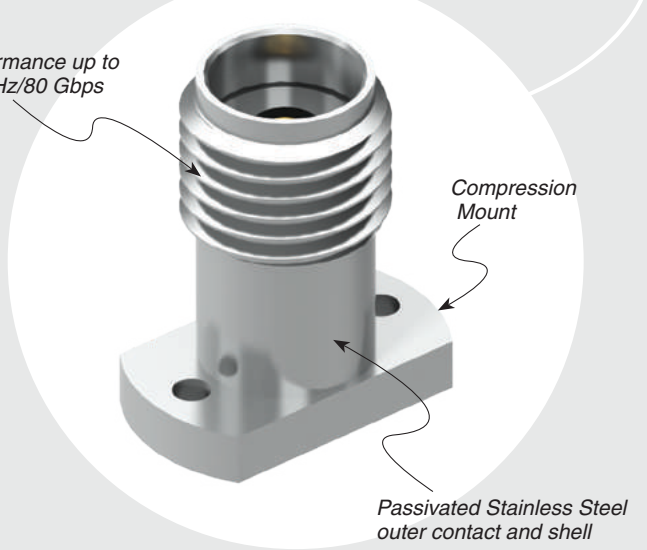

TYPE	GENDER	TYPE	PLATING	ORIENTATION	TERMINATION
<b>292</b> = Passivated Stainless Steel	<b>-J</b> = Jack	<b>-P</b> = PCB Mount	<b>-HP</b> = 30 μ" (0.76 μm) Gold center contact, Passivated outer contact	<b>-ST</b> = Straight	<b>-CM2</b> = Compression Mount

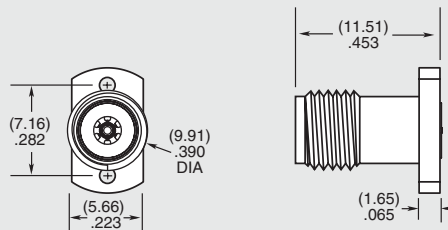

Due to technical progress, all designs, specifications and components are subject to change without notice.

292-J-C-HP-ST-CS3



292-P-C-HP-ST-CS3

292-CA SERIES

# 50 Ω 2.92 COMPONENTS

## SPECIFICATIONS

For complete specifications and assembly instructions see [www.samtec.com?292-CA](http://www.samtec.com?292-CA)

- Shell Material:** Stainless Steel
- Contact Material:** BeCu
- Cable Body:** Stainless Steel
- Insulator Material:** Ultem 1000
- Insert Material:** Stainless Steel

TYPE	GENDER	TYPE	PLATING	ORIENTATION	TERMINATION
<b>292</b> = Passivated Stainless Steel	<b>-J</b> = Jack	<b>-C</b> = Cable	<b>-HP</b> = 30 μm (0.76 μm) Gold center contact, Passivated outer contact	<b>-ST</b> = Straight	<b>-CS3</b> = MWC-2350-01 23 AWG Microwave Cable

## SPECIFICATIONS

For complete specifications and assembly instructions see [www.samtec.com?292-CA](http://www.samtec.com?292-CA)

- Shell Material:** Stainless Steel
- Contact Material:** BeCu
- Cable Body:** Stainless Steel
- Insulator Material:** Ultem 1000
- Gasket:** Silicone
- C-Ring:** Stainless Steel

TYPE	GENDER	TYPE	PLATING	ORIENTATION	TERMINATION
<b>292</b> = Passivated Stainless Steel	<b>-P</b> = Plug	<b>-C</b> = Cable	<b>-HP</b> = 30 μm (0.76 μm) Gold center contact, Passivated outer contact	<b>-ST</b> = Straight	<b>-CS3</b> = MWC-2350-01 23 AWG Microwave Cable

Due to technical progress, all designs, specifications and components are subject to change without notice.

[WWW.SAMTEC.COM](http://WWW.SAMTEC.COM)

All parts within this catalog are built to Samtec's specifications.  
Customer specific requirements must be approved by Samtec and identified in a Samtec customer-specific drawing to apply.



SMA-J-P-H-ST-TH1

SMA-J-P-H-RA-TH1



SMA-J-P-H-ST-EM1

# 50 Ω SMA JACKS

## SPECIFICATIONS

For complete specifications and recommended PCB layouts see [www.samtec.com?SMA-TH](http://www.samtec.com?SMA-TH), [www.samtec.com?SMA-SM](http://www.samtec.com?SMA-SM), [www.samtec.com?SMA-EM](http://www.samtec.com?SMA-EM) or [www.samtec.com?SMA-MT](http://www.samtec.com?SMA-MT)

- Contact Material:** BeCu
- Shell Material:** Brass
- Insulator Material:** PTFE (-PN)
- Operating Temp Range:** -65 °C to +125 °C
- Impedance:** 50 Ω
- Dielectric Withstanding Voltage:** 1,000 Vrms
- Frequency Range:** 0~20 GHz (Cable dependent)
- Working Voltage:** 335 V
- RoHS Compliant:** Yes

**Mates with:**  
 RF174, RF316, RF058,  
 RF405, RF402, RS316,  
 GRF1H-C, IJ5H, RF23S

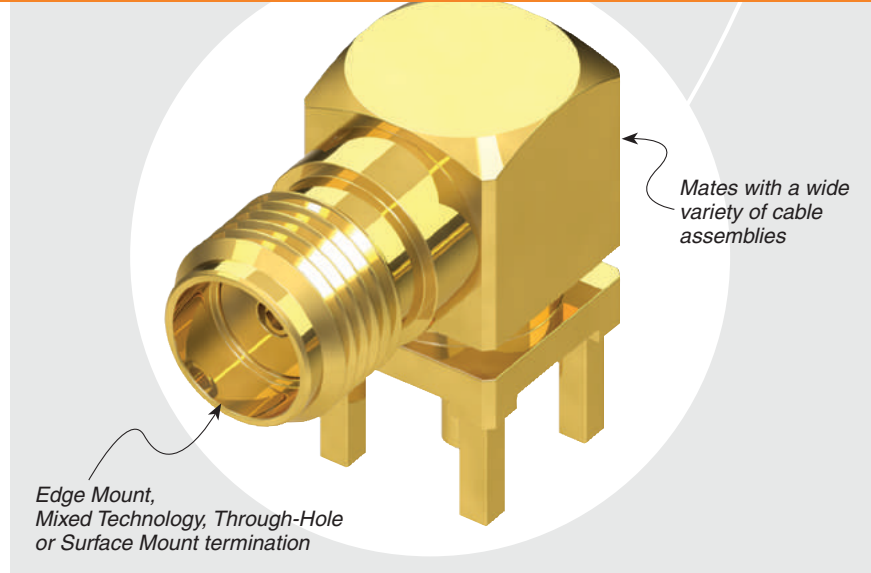

## PROCESSING

**Lead-Free Solderable:** Yes

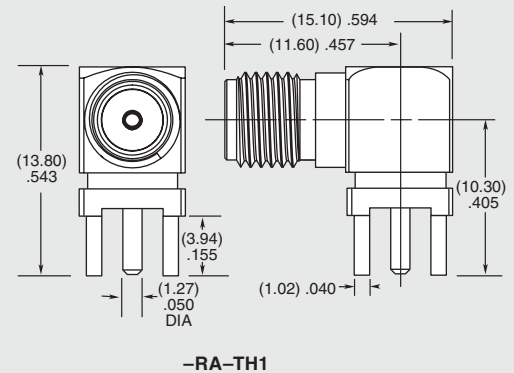
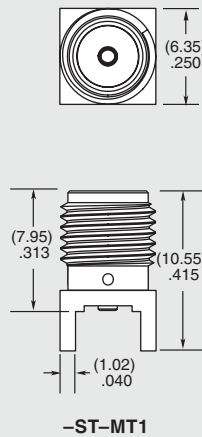
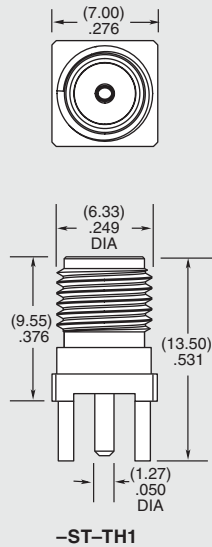
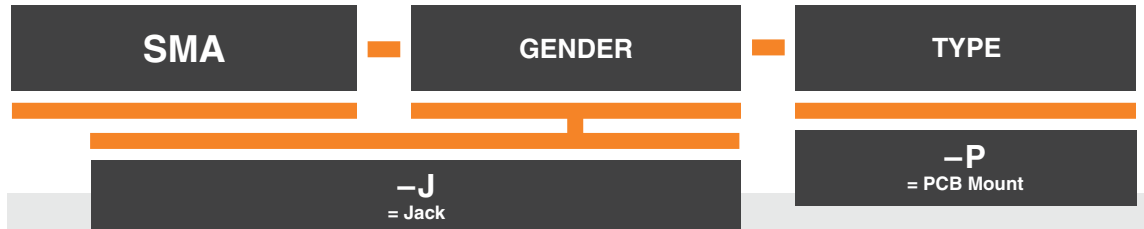

**Note:** While optimized for 50 Ω applications, this connector can also perform well in certain 75 Ω applications. Contact [RFGroup@samtec.com](mailto:RFGroup@samtec.com) for further information.

Due to technical progress, all designs, specifications and components are subject to change without notice.

[WWW.SAMTEC.COM](http://WWW.SAMTEC.COM)

All parts within this catalog are built to Samtec's specifications. Customer specific requirements must be approved by Samtec and identified in a Samtec customer-specific drawing to apply.

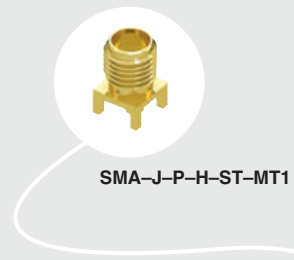
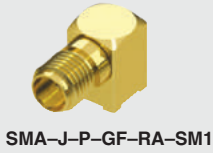

**SMA SERIES**

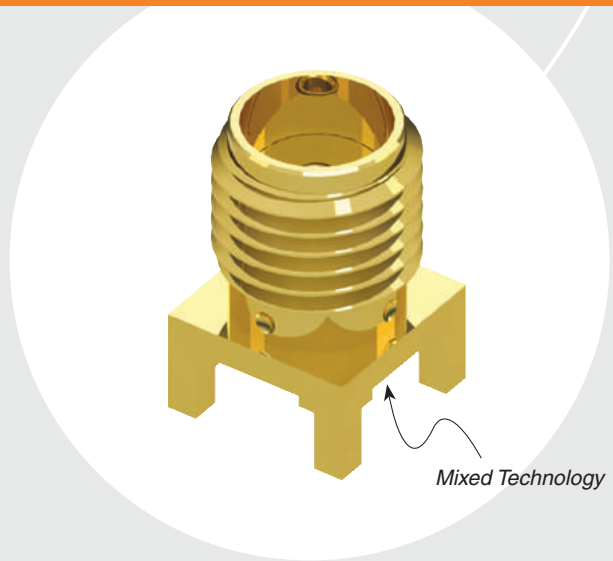
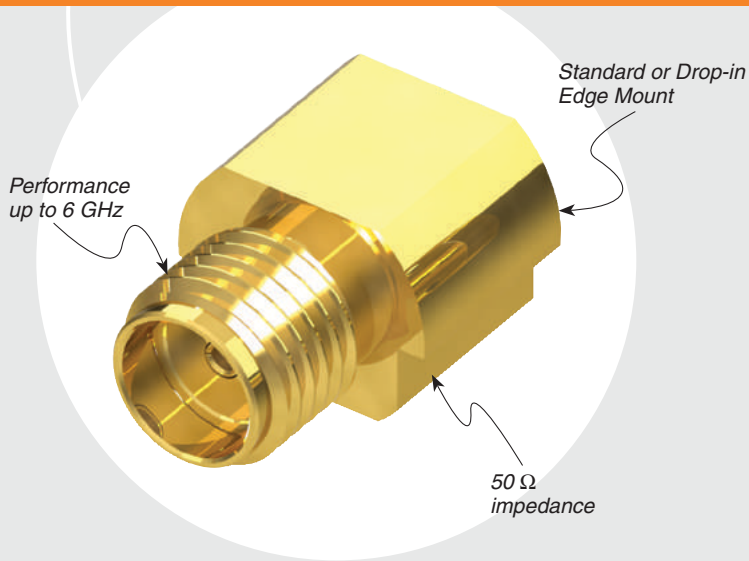

**PLATING**

**-H**

= 30 μ" (0.76 μm) Gold center contact,  
3 μ" (0.08 μm) Gold outer contact

**-GF**

= 10 μ" (0.25 μm) Gold center contact,  
3 μ" (0.08 μm) Gold outer contact  
(-SM1 only)

**ORIENTATION**

**-ST**

= Straight

**-RA**

= Right-angle

**TERMINATION**

**-TH1**

= Through-hole

**-SM1**

= Surface Mount  
(-GF-RA only)

**-EM1**

= Edge Mount  
(-ST only)

**-EM3**

= Drop-in Edge Mount  
(-ST only)

**-MT1**

= Mixed Technology  
(-ST only)

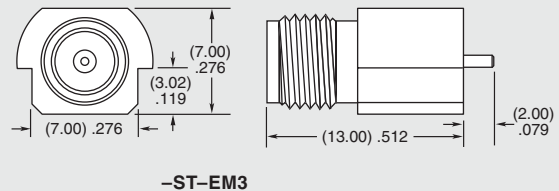
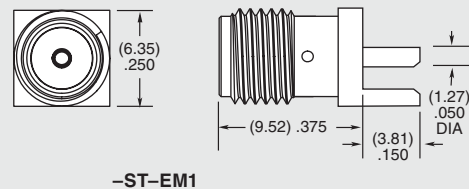
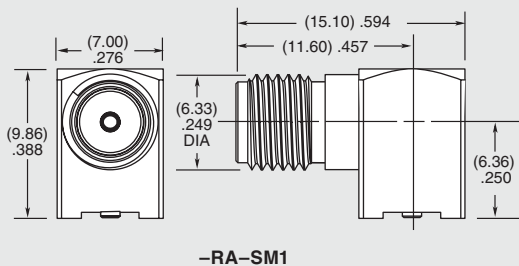

Due to technical progress, all designs, specifications and components are subject to change without notice.

[WWW.SAMTEC.COM](http://WWW.SAMTEC.COM)

All parts within this catalog are built to Samtec's specifications.  
Customer specific requirements must be approved by Samtec and identified in a Samtec customer-specific drawing to apply.

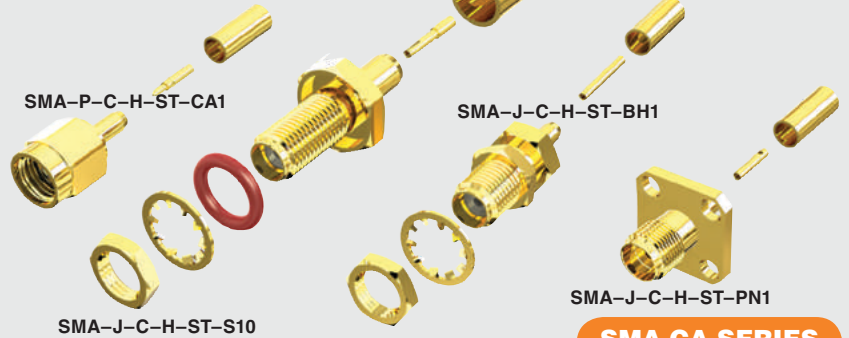
**SMA-CA SERIES**

# 50 Ω SMA COMPONENTS

**SPECIFICATIONS**

For complete specifications and assembly instructions see [www.samtec.com?SMA-CA](http://www.samtec.com?SMA-CA)

**Shell Material:**

Brass

**Contact Material:**

Brass

**Center Contact:**

Soldered

**Outer Ferrule:**

Crimped

**Operating Temperature:**

-65 °C to +125 °C

**Voltage Rating:**

335 V

**Dielectric Withstanding Voltage:**

1,000 Vrms

**Frequency Range:**

0~20 GHz  
(Cable dependent)

**Impedance:**

50 Ω

SMA	GENDER	TYPE	PLATING	ORIENTATION	TERMINATION
	<b>-J</b> = Jack	<b>-C</b> = Cable <b>-C4</b> = Cable 4-Mounting Screws (-PN1 only)	<b>-H</b> = 30 μ" (0.76 μm) Gold center contact, 3 μ" (0.08 μm) Gold outer contact (N/A with -BH1S) <b>-HF</b> = 30 μ" (0.76 μm) Gold center contact, 3 μ" (0.08 μm) Gold outer contact (-BH1S only)	<b>-ST</b> = Straight	<b>-BH1</b> = Bulkhead RG 174 / 316 Cable <b>-BH2</b> = Bulkhead RG 178 Cable <b>-BR1</b> = Bulkhead RG 174 / 316, Reversed Polarity <b>-BR2</b> = Bulkhead RG 178 Cable, Reversed Polarity <b>-BH1S</b> = Bulkhead RG 316 Cable, Double Shield <b>-B10</b> = Bulkhead RG 58 Cable <b>-PN1</b> = 4-Hole Panel Mount RG 174 / 316 Cable <b>-S10</b> = Sealed Bulkhead RG 58 Cable
		<b>-BH1, -BH2, -BR1, -BR2, BH1S</b>			<b>-S10, -B10</b>

Supplied with pins, washers, nuts and ferrules. See website for dimensions.

SMA	GENDER	TYPE	PLATING	ORIENTATION	TERMINATION
	<b>-P</b> = Plug	<b>-C</b> = Cable	<b>-H</b> = 30 μ" (0.76 μm) Gold center contact, 3 μ" (0.08 μm) Gold outer contact (-CA1, -CA10 only) <b>-HF</b> = 30 μ" (0.76 μm) Gold center contact, 3 μ" (0.08 μm) Gold outer contact (-CA7, -CA9, -CA1S only)	<b>-ST</b> = Straight <b>-RA</b> = Right-angle	<b>-CA1</b> = RG 174 / 316 Cable <b>-CA7</b> = RG 405 (.086" DIA) Semi-flexible Cable <b>-CA9</b> = RG 402 (.141" DIA) Semi-flexible Cable <b>-C10</b> = RG 58 Cable (-ST only) <b>-CA1S</b> = RG 316 Double Shielded Cable (-ST only)
					<b>-ST-CA9 &amp; -ST-C10</b>

Supplied with pins and ferrules. See website for dimensions.

Due to technical progress, all designs, specifications and components are subject to change without notice.

[WWW.SAMTEC.COM](http://WWW.SAMTEC.COM)

All parts within this catalog are built to Samtec's specifications.

Customer specific requirements must be approved by Samtec and identified in a Samtec customer-specific drawing to apply.

SMP-J-B-GF-ST-1450



SMP-J-C-GF-ST-CA5



SMP-PF-P-HH-ST-EM3



SMP-PF-P-GF-ST-TH2



SMP-J-C-GF-RA-CA7

**SMP SERIES**

# 50 Ω SMP JACKS/PLUGS & ADAPTOR

**SMP-PF, SMP-PL, SMP-PS, SMP-PC**  
 Mate with:  
 SMP-B Bullet Adaptor

**Cable Mates:**  
 RF405, RF25S

**SPECIFICATIONS**

For complete specifications see [www.samtec.com?SMP-TH](http://www.samtec.com?SMP-TH), [www.samtec.com?SMP-EM](http://www.samtec.com?SMP-EM), [www.samtec.com?SMP-B](http://www.samtec.com?SMP-B) or [www.samtec.com?SMP-CA](http://www.samtec.com?SMP-CA)

**Shell Material:**  
 Au plated Brass (-TH2, -EM3)  
 Au plated BeCu (-J-B, -J-C)

**Contact Material:**  
 Brass (-TH2, -EM3)  
 BeCu (-CA)

**Insulator Material:**  
 PTFE

**Impedance:**  
 50 Ω

**Frequency Range:**  
 DC to 40 GHz,  
 DC to 20 GHz (25 AWG)

**Working Voltage:**  
 335 Vrms min

**Dielectric Withstanding:**  
 500 Vrms min

**Engagement Force:**  
 -PF: 15 lbs. max  
 -PL: 10 lbs. max  
 -PS & -PC: 2 lbs. max

**Disengagement Force:**  
 -PF: 2 lbs. min  
 -PL: 2 lbs. min  
 -PS & -PC: 0.5 lbs. min

**Operating Temperature:**  
 -65 °C to +165 °C

**RoHS Compliant:**  
 Yes

**PROCESSING**

**Lead-Free Solderable:**  
 Yes

**ALTERNATIVE SOLUTIONS**

The SMP Series is an alternative to the Corning Gilbert GPO Series. A mini SMP Series, available as an ASO, is an alternative to the Corning Gilbert GPPO Series.

**Note:**  
 While optimized for 50 Ω applications, this connector can also perform well in certain 75 Ω applications. Contact [RFGroup@samtec.com](mailto:RFGroup@samtec.com) for further information.

SMP	GENDER	TYPE	PLATING	ORIENTATION	TERMINATION
		-P = PCB Mount	-GF = 10 μ" (0.25 μm) Gold center contact, Gold Flash outer contact (-TH2 only)	-ST = Straight	-TH2 = Through-hole
		-PF = Plug, Full Detent	-HH = 30 μ" (0.76 μm) Gold center and outer contact (-EM3)		-EM3 = Drop-in Edge Mount (Not available with -PC)
		-PL = Plug, Limited Detent			
		-PS = Plug, Smooth Bore			
		-PC = Plug, Catcher's Mitt			

GENDER	A DIA
-PF	(4.19) .165
-PL	(4.19) .165
-PS	(4.19) .165
-PC	(5.99) .236

**APPLICATION**

LENGTH	BOARD SPACE
-0645	(9.05) .356
-1450	(17.10) .673

**EXTRACTION TOOL**

- CAT-EX-SMP-01 Contact Samtec

SMP	J	TYPE	PLATING	ORIENTATION	BULLET LENGTH	CABLE END
		-B = Bullet Adaptor	-GF = 10 μ" (0.25 μm) Gold center contact, Gold Flash outer contact	-ST = Straight	Leave blank for cable end	Leave blank for bullet type
		-C = Cable End	-RA = Right-angle (Not available with -B)		-0645 = 6.45 mm (.254")	-CA7 = RG 405 (.086" DIA) Semi-flexible Cable
					-1450 = 14.50 mm (.571")	-CA5 = CCA-25M Cable
						-CS5 = MWC-2550-01 25 AWG Microwave Cable

Due to technical progress, all designs, specifications and components are subject to change without notice.

[WWW.SAMTEC.COM](http://WWW.SAMTEC.COM)

All parts within this catalog are built to Samtec's specifications. Customer specific requirements must be approved by Samtec and identified in a Samtec customer-specific drawing to apply.

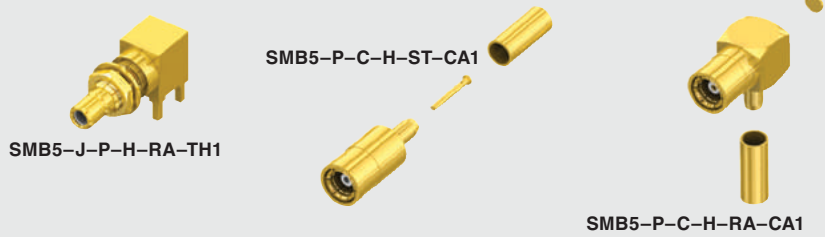

**SMB5 SERIES**

# 50 Ω SMB JACKS & PLUGS

Mates with:  
RF174, RF316, GRF1H-C

**SPECIFICATIONS**

For complete specifications and recommended PCB layouts see [www.samtec.com?SMB5-TH](http://www.samtec.com?SMB5-TH)

- Shell Material: Brass
- Contact Material: Brass
- Insulator Material: PTFE
- Impedance: 50 Ω
- Frequency Range: 0-4 GHz
- Working Voltage: 250 Vrms max
- Dielectric Withstanding: 750 Vrms min
- Operating Temp Range: -65 °C to +165 °C
- RoHS Compliant: Yes

**PROCESSING**

Lead-Free Solderable: Yes

Note: 75 Ω version available. See SMB7H Series.

SMB5	GENDER	TYPE	PLATING	ORIENTATION	TERMINATION
	-J = Jack	-P = PCB Mount	-H = 30 μ" (0.76 μm) Gold center contact, 3 μ" (0.08 μm) Gold outer contact	-RA = Right-angle	-TH1 = Through-hole

**SPECIFICATIONS**

For complete specifications and assembly instructions see [www.samtec.com?SMB5-CA](http://www.samtec.com?SMB5-CA)

- Shell Material: Brass
- Contact Material: Brass (-J), Phosphor Bronze (-P-ST), BeCu (-P-RA)
- Center Contact: Soldered
- Outer Ferrule: Crimped
- Insulator Material: PTFE
- Impedance: 50 Ω
- Frequency Range: 0-4 GHz
- Working Voltage: 335 Vrms max
- Dielectric Withstanding: 1000 Vrms min
- Operating Temp Range: -65 °C to +165 °C

SMB5	GENDER	TYPE	PLATING	ORIENTATION	TERMINATION
	-P = Plug -J = Jack	-C = Cable	-H = 30 μ" (0.76 μm) Gold center contact, 3 μ" (0.08 μm) Gold outer contact	-ST = Straight -RA = Right-angle (-P only)	-CA1 = RG 174/316 Cable (-P only) -CA2 = RG 178 Cable (-J only) -BH1 = RG 316 Cable (-J only)

Supplied with pins, washers, nuts and ferrules. See website for dimensions.

*Due to technical progress, all designs, specifications and components are subject to change without notice.*

[WWW.SAMTEC.COM](http://WWW.SAMTEC.COM)

All parts within this catalog are built to Samtec's specifications. Customer specific requirements must be approved by Samtec and identified in a Samtec customer-specific drawing to apply.



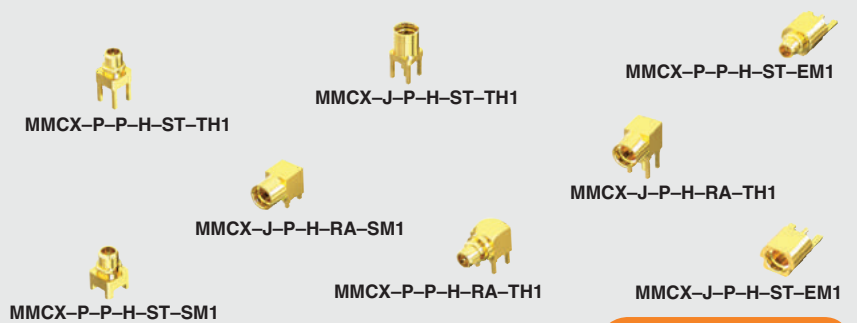

**MMCX SERIES**

# 50 Ω MMCX MICRO-MINI JACKS & PLUGS

**Mates with:**  
RF174, RF316, RF178,  
RS316, GRF1H-C

**SPECIFICATIONS**

For complete specifications and recommended PCB layouts see [www.samtec.com?MMCX-EM](http://www.samtec.com?MMCX-EM), [www.samtec.com?MMCX-MT](http://www.samtec.com?MMCX-MT), [www.samtec.com?MMCX-SM](http://www.samtec.com?MMCX-SM) or [www.samtec.com?MMCX-TH](http://www.samtec.com?MMCX-TH)

**Contact Material:** BeCu  
**Insulator Material:** PTFE  
**Pin and Shell Material:** Brass  
**Operating Temp Range:** -65 °C to +125 °C  
**Impedance:** 50 Ω  
**Dielectric Withstanding Voltage:** 500 Vrms, 50 Hz  
**Dielectric Working Voltage:** 170 Vrms, 50Hz  
**Frequency Range:** 0-6 GHz  
**RoHS Compliant:** Yes

**PROCESSING**

**Lead-Free Solderable:** Yes

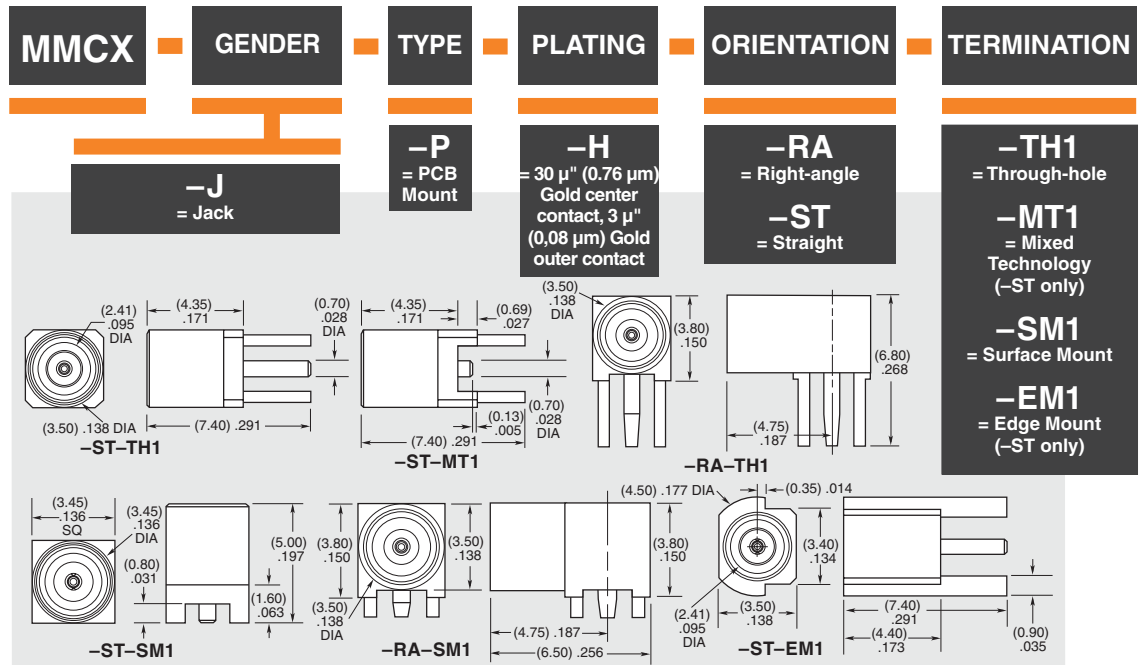

**OTHER SOLUTIONS**

- High Vibration jacks and plugs. These connectors are not interchangeable with the MMCX.
  - MMCX Jack that switches from internal to external antenna when cable is mated.
- Contact Samtec.

**Notes:**  
Random vibration and Resonant Search test reports available online.

75 Ω version available. See MMCX7 Series.

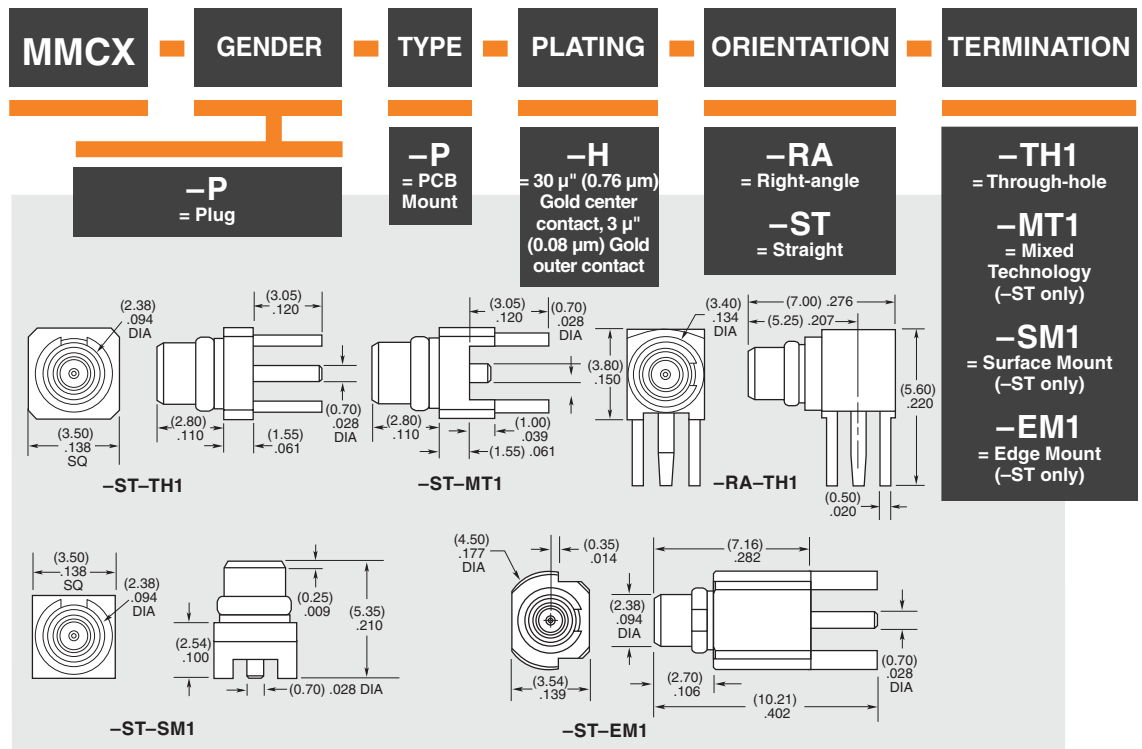

Due to technical progress, all designs, specifications and components are subject to change without notice.

[WWW.SAMTEC.COM](http://WWW.SAMTEC.COM)

All parts within this catalog are built to Samtec's specifications. Customer specific requirements must be approved by Samtec and identified in a Samtec customer-specific drawing to apply.

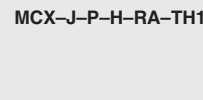
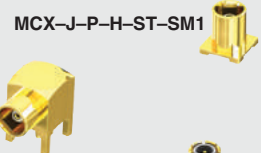

MCX SERIES

# 50 $\Omega$ MCX MINI JACKS & PLUGS

### Mates with:

RF174, RF316, RF178,  
 RS316, GRF1H-C

### SPECIFICATIONS

For complete specifications and recommended PCB layouts see [www.samtec.com?MCX-TH](http://www.samtec.com?MCX-TH), [www.samtec.com?MCX-SM](http://www.samtec.com?MCX-SM), [www.samtec.com?MCX-EM](http://www.samtec.com?MCX-EM) or [www.samtec.com?MCX-MT](http://www.samtec.com?MCX-MT)

**Insulator Material:** PTFE  
**Contact Material:** BeCu, Brass (-P-TH)  
**Shell Material:** Brass  
**Operating Temp Range:** -65 °C to +125 °C  
**Impedance:** 50  $\Omega$   
**Dielectric Withstanding Voltage:** 1000 Vrms min, 50 Hz  
**Dielectric Working Voltage:** 335 Vrms max  
**Frequency Range:** 0-6 GHz  
**RoHS Compliant:** Yes

### PROCESSING

**Lead-Free Solderable:** Yes

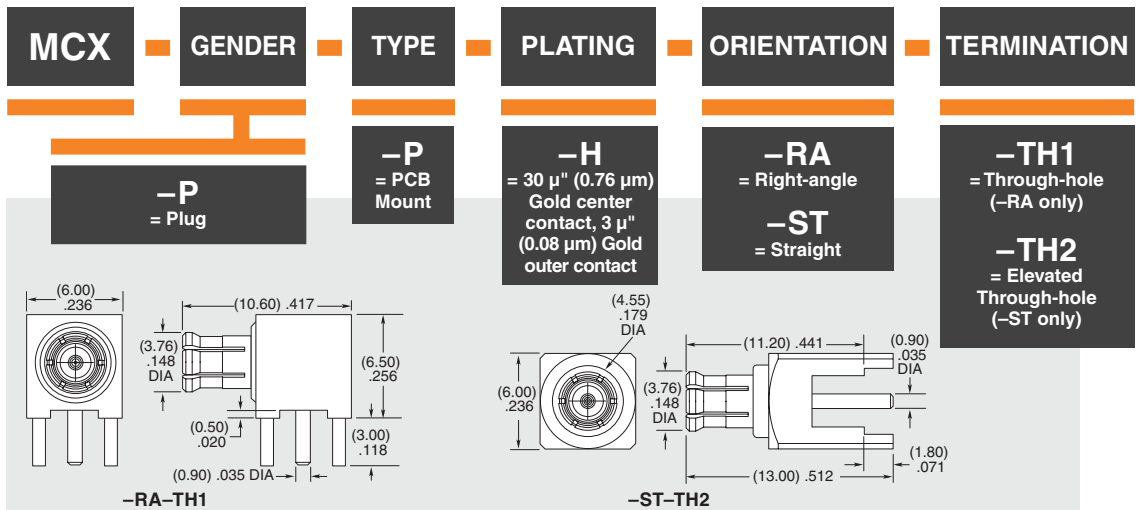
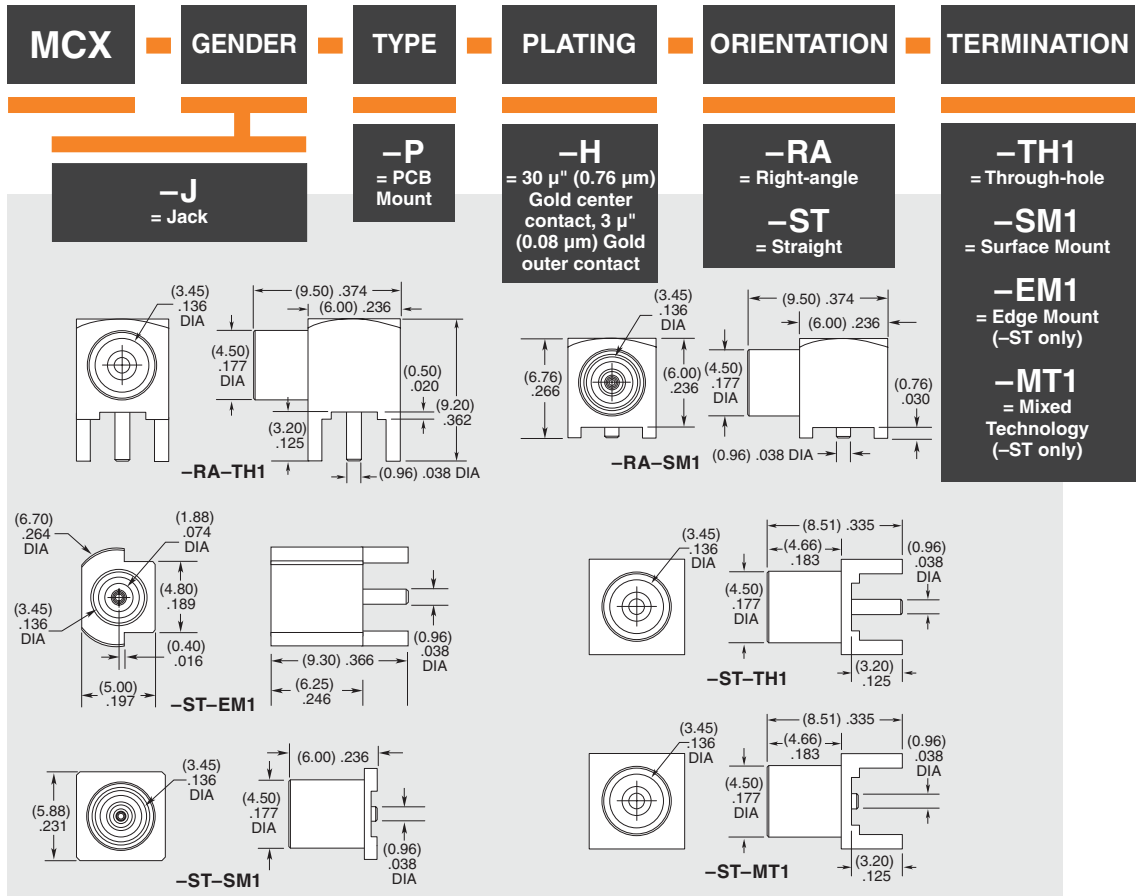

**Note:** 75  $\Omega$  version available. See MCX7 Series.

Due to technical progress, all designs, specifications and components are subject to change without notice.

[WWW.SAMTEC.COM](http://WWW.SAMTEC.COM)

All parts within this catalog are built to Samtec's specifications. Customer specific requirements must be approved by Samtec and identified in a Samtec customer-specific drawing to apply.

MMCX-P-C-H-RA-CA2



MCX-J-C-H-ST-CA1



MCX-P-C-H-RA-CA1



MMCX-CA, MCX-CA SERIES

# 50 Ω MMCX & MCX COMPONENTS

## SPECIFICATIONS

For complete specifications and assembly instructions see [www.samtec.com?MMCX-CA](http://www.samtec.com?MMCX-CA)

- Shell Material: Brass
- Insulator Material: PTFE
- Lead, Contact Socket and Outer Conductor Material: BeCu with Au plating
- Center Contact: Soldered
- Outer Ferrule: Crimped
- Operating Temp Range: -65 °C to +125 °C
- Impedance: 50 Ω
- Dielectric Withstanding Voltage: 500 Vrms, 50 Hz
- Dielectric Working Voltage: 170 Vrms, 50 Hz
- Frequency Range: 0-6 GHz (Cable dependent)

MMCX — GENDER — TYPE — PLATING — ORIENTATION — TERMINATION

**-P**  
= Plug

**-C**  
= Cable

**-H**  
= 30 μ" (0.76 μm) Gold center contact, 3 μ" (0.08 μm) Gold outer contact (-CA1 & -CA2 only)

**-HF**  
= 30 μ" (0.76 μm) Gold center contact, 3 μ" (0.08 μm) Gold outer contact (-CA1S only)

**-RA**  
= Right-angle

**-ST**  
= Straight

**-CA1**  
= RG 174/316 Cable

**-CA2**  
= RG 178 Cable

**-CA1S**  
= RG 316 Cable, Double Shield (-ST only)

**-RA-CA1 & -RA-CA2**

**-ST-CA1, -ST-CA2 & -ST-CA1S**

Supplied with pins and ferrules. See website for dimensions.

## SPECIFICATIONS

For complete specifications and assembly instructions see [www.samtec.com?MCX-CA](http://www.samtec.com?MCX-CA)

- Insulator Material: PTFE
- Contact Material: BeCu
- Shell and Pin Material: Brass
- Center Contact: Soldered
- Outer Ferrule: Crimped
- Operating Temp Range: -65 °C to +125 °C
- Impedance: 50 Ω
- Frequency Range: 0-6 GHz (Cable dependent)
- Dielectric Withstanding Voltage: 1,000 Vrms min, 50 Hz
- Dielectric Working Voltage: 335 Vrms max.

MCX — GENDER — TYPE — PLATING — ORIENTATION — TERMINATION

**-J**  
= Jack

**-P**  
= Plug

**-C**  
= Cable

**-H**  
= 30 μ" (0.76 μm) Gold center contact, 3 μ" (0.08 μm) Gold outer contact (-CA1 & -CA2 only)

**-HF**  
= 30 μ" (0.76 μm) Gold center contact, 3 μ" (0.08 μm) Gold outer contact (-CA1S only)

**-RA**  
= Right-angle (-P only)

**-ST**  
= Straight

**-CA1**  
= RG 174/316 Cable

**-CA2**  
= RG 178 Cable

**-CA1S**  
= RG 316 Cable, Double Shield (-ST only)

TYPE (-RA)	A	B
-P-CA1	(7.78) .306	(9.50) .374
-P-CA2	(8.58) .338	(10.00) .394

TYPE (-ST)	E	F
-J-CA1	(4.50) .177	(15.50) .610
-J-CA2	(4.78) .188	(15.00) .591
-J-CA1S	(4.50) .177	(15.50) .610

**-RA**

**-P-ST**

**J-ST**

Supplied with pins and ferrules. See website for dimensions.

Due to technical progress, all designs, specifications and components are subject to change without notice.

BNC5-P-C-GN-ST-CA1



BNC5-J-C-GN-ST-BH1

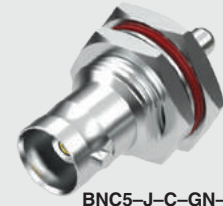

BNC5 SERIES

# 50 Ω BNC CABLE COMPONENTS

## SPECIFICATIONS

For complete specifications and assembly instructions see [www.samtec.com?BNC5-CA](http://www.samtec.com?BNC5-CA)

### Shell Material:

Brass

### Contact Material:

Brass (-P)

Copper Alloy (-J)

### Center Contact:

Soldered

### Outer Contact:

Crimped

### Impedance:

50 Ω

### Frequency Range:

0-4 GHz

(Cable dependent)

### Working Voltage:

500 Vrms max

### Dielectric Withstanding:

1500 Vrms min

### Operating Temp Range:

-65 °C to +125 °C

Locking feature

Fits RG 174,  
RG 178 &  
RG 316 cable

Plug or jack

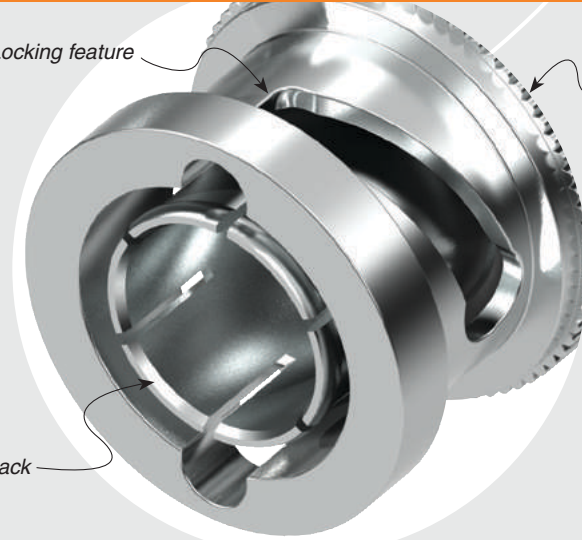

BNC5

GENDER

TYPE

PLATING

ORIENTATION

TERMINATION

-P  
= Plug-J  
= Jack-C  
= Cable

-GN  
= 10 μ"  
(0.25 μm)  
Gold on  
contact,  
Nickel on  
body

-ST  
= Straight

-CA1  
= RG 174 / 316 Cable  
(-P only)

-CA2  
= RG 178 Cable  
(-P only)

-BH1  
= Bulkhead,  
RG 174 / 316 Cable  
(-J only)

-BH2  
= Bulkhead,  
RG 178 Cable  
(-J only)

-BH1S  
= Bulkhead,  
RG 316 Cable,  
Double Shield  
(-J only)

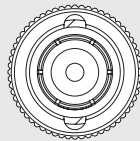

-P

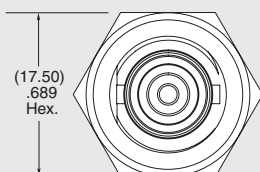
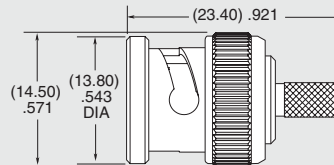

-J

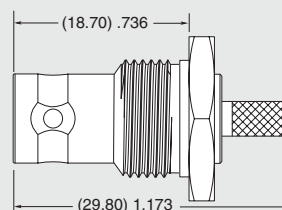

Supplied with pins, washers, nuts, gaskets and ferrules. See website for dimensions.

*Due to technical progress, all designs, specifications and components are subject to change without notice.*

[WWW.SAMTEC.COM](http://WWW.SAMTEC.COM)

All parts within this catalog are built to Samtec's specifications.

Customer specific requirements must be approved by Samtec and identified in a Samtec customer-specific drawing to apply.

## OTHER SOLUTIONS

- 50 Ω BNC Board Jacks
  - 50 Ω TNC Board Jacks
  - 50 Ω TNC Cable Components
- Contact Samtec.

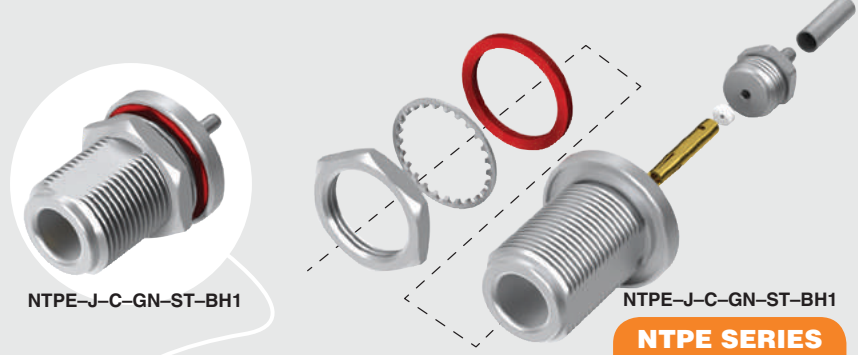

# 50 Ω N TYPE RF COMPONENTS

## SPECIFICATIONS

For complete specifications and assembly instructions see [www.samtec.com?NTPE-CA](http://www.samtec.com?NTPE-CA)

- Shell Material:**  
Brass
- Contact Material:**  
Phosphor Bronze
- Insulator Material:**  
PTFE
- Center Contact:**  
Soldered
- Outer Contact:**  
Crimped
- Impedance:**  
50 Ω
- Frequency Range:**  
0~3 GHz  
(Cable dependent)
- Working Voltage:**  
1000 Vrms max
- Dielectric Withstanding:**  
2500 Vrms min
- Operating Temp Range:**  
-65 °C to +125 °C

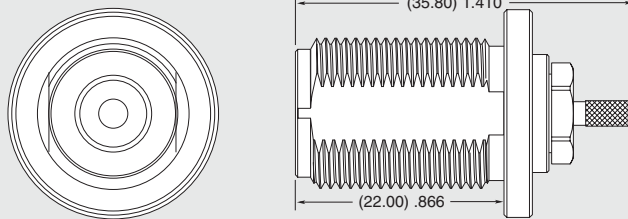
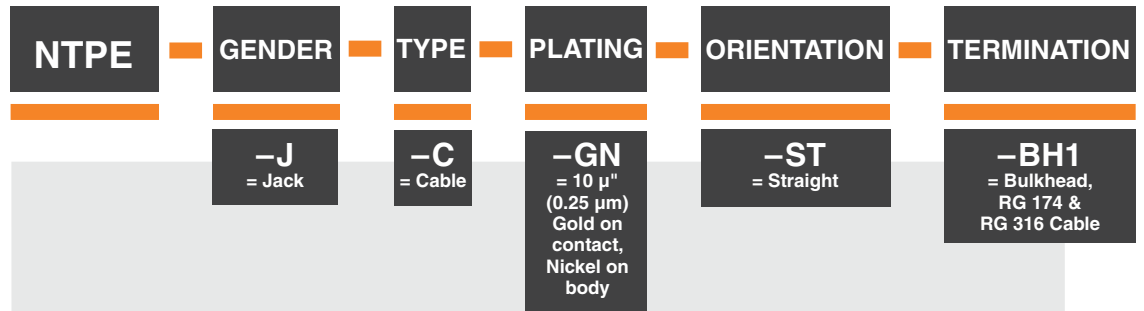
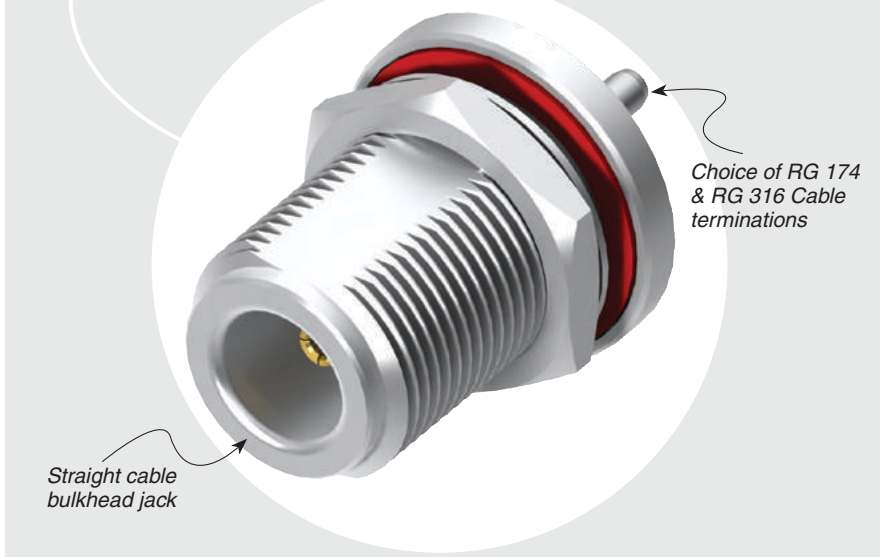

Supplied with pins, washers, nuts, gaskets and ferrules. See website for dimensions.

Due to technical progress, all designs, specifications and components are subject to change without notice.

[WWW.SAMTEC.COM](http://WWW.SAMTEC.COM)

*All parts within this catalog are built to Samtec's specifications.  
Customer specific requirements must be approved by Samtec and identified in a Samtec customer-specific drawing to apply.*

TNC-J-C-GN-ST-BH1



TNC-J-P-H-RA-TH1



**TNC SERIES**

# 50 Ω TNC JACKS & PLUGS

Mates with:  
RF058, RF178, RF316,  
RF174, GRF1H-C

## SPECIFICATIONS

For complete specifications and recommended PCB layouts see [www.samtec.com?TNC-TH](http://www.samtec.com?TNC-TH)

- Outer Contact Material:** Ni plated Brass
- Center Contact Material:** Au plated Phosphor Bronze
- Insulator Material:** PTFE
- Operating Temperature:** -65 °C to +125 °C
- Impedance:** 50 Ω
- Frequency Range:** 0~6 GHz
- Working Voltage:** 500 Vrms max
- Dielectric Withstanding:** 1500 Vrms min
- RoHS Compliant:** Yes

## PROCESSING

**Lead-Free Solderable:**  
Yes

TNC	GENDER	TYPE	PLATING	ORIENTATION	TERMINATION
	-J = Jack	-P = PCB Mount	-H = 30 μ" (0.76 μm) Gold on center contact, Nickel on Shell	-RA = Right-angle	-TH1 = Through-hole

**Note:**  
While optimized for 50 Ω applications, this connector can also perform well in certain 75 Ω applications. Contact [RFGroup@samtec.com](mailto:RFGroup@samtec.com) for further information.

## SPECIFICATIONS

For complete specifications and assembly instructions see [www.samtec.com?TNC-CA](http://www.samtec.com?TNC-CA)

- Shell Material:** Brass
- Contact Material:** Brass (-P-ST), Phosphor Bronze (-J)
- Center Contact:** Soldered
- Outer Ferrule:** Crimped
- Impedance:** 50 Ω
- Frequency Range:** 0~3 GHz (Cable dependent)
- Working Voltage:** 500 Vrms max
- Dielectric Withstanding:** 1500 Vrms min
- Operating Temp Range:** -65 °C to +125 °C

**ALSO AVAILABLE (MOQ Required)**

- IP67 sealed option Contact Samtec.

TNC	GENDER	TYPE	PLATING	ORIENTATION	TERMINATION
	-P = Plug  -J = Jack	-C = Cable	-GN = 10 μ" (0.25 μm) Gold on contact, Nickel on body	-ST = Straight  -SR = Straight Reverse Polarity (-P only)	-CA1 = RG 174 / 316 Cable (-P & -ST only)  -CA2 = RG 178 Cable (-P & -ST only)  -C10 = RG 58 Cable (-P & -SR only)  -BH1 = Bulkhead, RG 174 / 316 Cable (-J & -ST only)  -BH2 = Bulkhead, RG 178 Cable (-J & -ST only)

Supplied with pins, washers, nuts and ferrules. See website for dimensions.

Due to technical progress, all designs, specifications and components are subject to change without notice.

DIN7A-PP-C-GF-ST-CA3

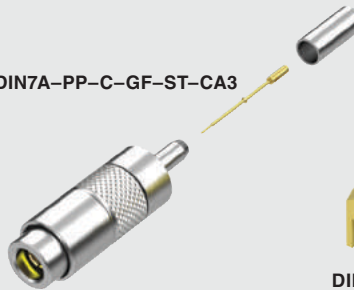

DIN7A-J-P-GF-RA-BH1

DIN7A-J-P-GF-ST-TH1



DIN7A SERIES

# 75 Ω DIN 1.0/2.3 JACKS & PLUGS

Mates with:  
RFB8T, RFA6T, RFB6T,  
RF179, GRF7H-C

## SPECIFICATIONS

For complete specifications see  
www.samtec.com?DIN7A-TH,  
www.samtec.com?DIN7A-BH or  
www.samtec.com?DIN7A-CA

**Shell Material:**

Brass

**Contact:**

Copper Alloy

**Insulator Material:**

PTFE

**Operating Temp Range:**

-65 °C to +125 °C

**Impedance:**

75 Ω

**Working Voltage:**

250 Vrms

**Dielectric Withstanding:**

750 Vrms

DIN7A	GENDER	TYPE	PLATING	ORIENTATION	TERMINATION
	-J = Jack	-P = PCB Mount	-GF = 10 μ" (0.25 μm) Gold center contact, 3 μ" (0.08 μm) Gold outer contact, (100 μ" (2.54 μm) Nickel body -RA only)	-ST = Straight (-TH1 only)  -RA = Right-angle (-BH1 only)	-TH1 = Through-hole (-ST only)  -BH1 = Bulkhead Through-hole (-RA only)
	<p>-ST-TH1</p>				
	<p>-RA-BH1</p>				

**Notes:**  
12G-SDI available for PCB mounts only.  
Contact RFTechnicalGroup@samtec.com for 12G-SDI PCB mount launch characteristics.  
Designed to meet SMPTE 2082 12G-SDI specifications.

DIN7A	PP	TYPE	PLATING	ORIENTATION	TERMINATION
	-PP = Push Pull Plug	-C = Cable	-GF = 10 μ" (0.25 μm) Gold on contact, Flash Gold on outer contact, Nickel on shell	-ST = Straight	-CA3 = RG 179 Cable  -CA6 = RG 6 or Belden 1694A Cable  -CA8 = Belden 1855A Cable
	<p>-CA6 SHOWN</p>				

Supplied with pins and ferrules. See website for dimensions.

*Due to technical progress, all designs, specifications and components are subject to change without notice.*



HDBNC-J-P-GN-ST-EM1



HDBNC-J-P-GN-ST-BH1



HDBNC-J-P-GN-RA-BH1



HDBNC-J-P-GN-ST-TH1

**HDBNC SERIES**

# 75 Ω HIGH-DENSITY BNC JACKS

## SPECIFICATIONS

For complete specifications and recommended PCB layouts see [www.samtec.com?HDBNC-TH](http://www.samtec.com?HDBNC-TH), [www.samtec.com?HDBNC-BH1](http://www.samtec.com?HDBNC-BH1) or [www.samtec.com?HDBNC-EM](http://www.samtec.com?HDBNC-EM)

**Shell Material:**

Au plated Brass

**Contact Material:**

Copper Alloy

**Insulator Material:**

PTFE

**Impedance:**

75 Ω ±2 Ω

**Voltage Rating:**

500 VAC

**Dielectric Withstanding:**

1500 Vrms min

**Operating Temperature:**

-65 °C to +125 °C

**RoHS Compliant:**

Yes

**Lead-Free Solderable:**

Yes

**Mates with:**

RFB6T, RFB8T, RFA6T

Patented design and bayonet latch

20% reduction in weight of traditional BNCs

Extended performance of 12G for high density terminations

### 4X THE PANEL DENSITY

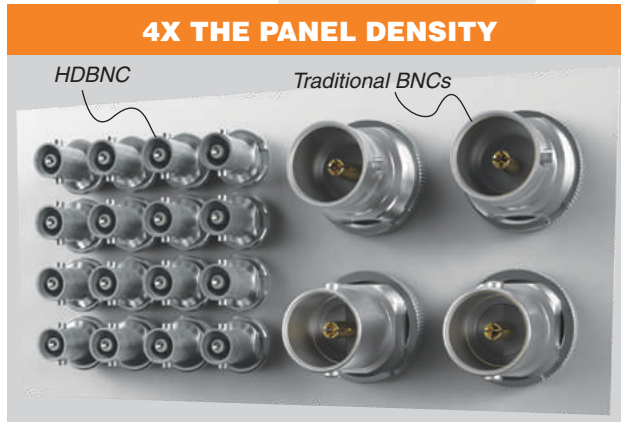

## EXTRACTION TOOL

- Hand tool for quickly installing/uninstalling HDBNC Series.
- Part Number: CAT-EX-HDBNC-01
- Contact Samtec.

HDBNC	GENDER	TYPE	PLATING	ORIENTATION	TERMINATION
-J	= Jack	-P = PCB Mount	-GN = 10 μ" (0.25 μm) Gold contact, 100 μ" (2.54 μm) Nickel shell	-ST = Straight  -RA = Right-angle	-BH1 = Through-hole  -BH2 = Through-hole (2.36 mm) .093 Board (-RA only)  -EM1 = Edge Mount (-ST only)  -TH1 = Through-hole (-ST only)

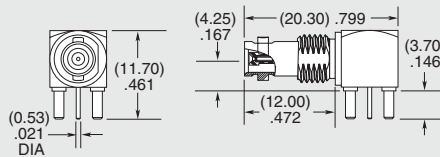

HDBNC-RA

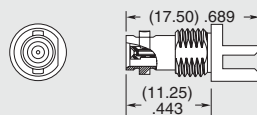

HDBNC-EM1

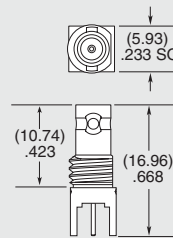

HDBNC-BH1

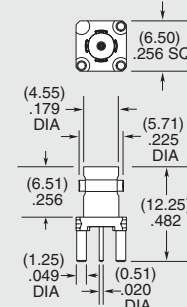

HDBNC-TH1

**Notes:**  
Compatible with Amphenol's HD-BNC™

Designed to meet SMPTE 424M 12G-SDI specifications.

Due to technical progress, all designs, specifications and components are subject to change without notice.

[WWW.SAMTEC.COM](http://WWW.SAMTEC.COM)

All parts within this catalog are built to Samtec's specifications. Customer specific requirements must be approved by Samtec and identified in a Samtec customer-specific drawing to apply.



HDBNC-P-C-GN-ST-CA8

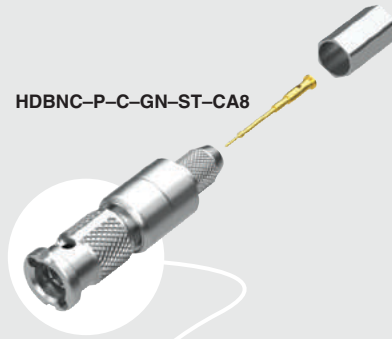

HDBNC-P-C-GN-ST-CA6



**HDBNC-CA SERIES**

# 75 Ω HIGH-DENSITY BNC COMPONENTS

**SPECIFICATIONS**

For complete specifications and assembly instructions see [www.samtec.com?HDBNC-CA](http://www.samtec.com?HDBNC-CA)

- Shell Material:**  
Brass
- Contact Material:**  
Brass
- Center Contact:**  
Soldered
- Outer Ferrule:**  
Crimped
- Impedance:**  
75 Ω
- Voltage Rating:**  
500 VAC
- Dielectric Withstanding:**  
1000 Vrms
- Operating Temperature:**  
-65 °C to +125 °C

*Crimp style plugs use industry standard termination tools*

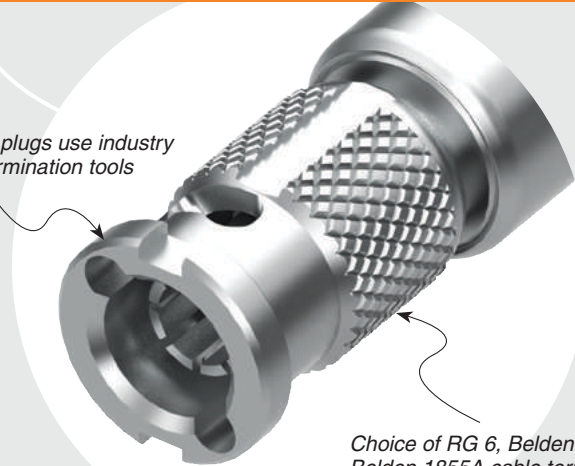

*Choice of RG 6, Belden 1694A or Belden 1855A cable terminations*

**EXTRACTION TOOL**

- Hand tool for quickly installing/uninstalling HDBNC Series.  
Part Number: CAT-EX-HDBNC-01  
Contact Samtec.

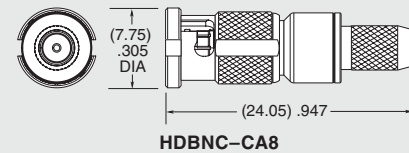
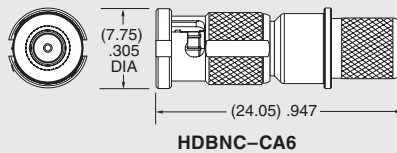
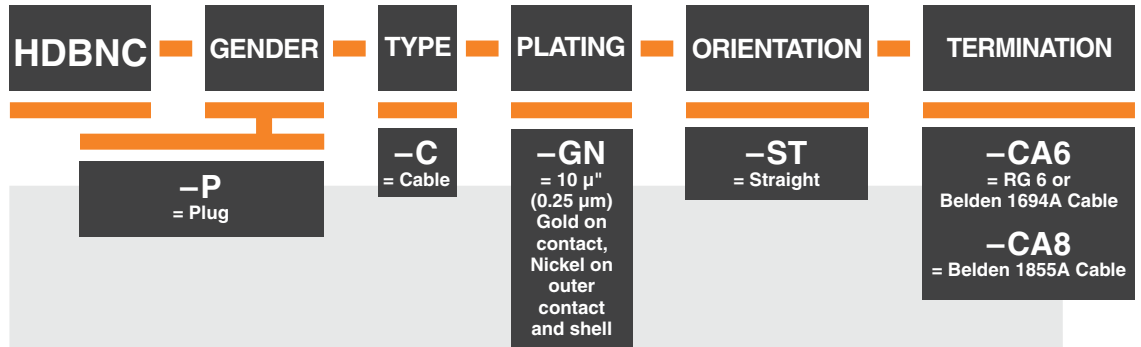

**Notes:**  
Compatible with Amphenol's HD-BNC™

Supplied with pins and ferrules. See website for dimensions.

*Due to technical progress, all designs, specifications and components are subject to change without notice.*

[WWW.SAMTEC.COM](http://WWW.SAMTEC.COM)

*All parts within this catalog are built to Samtec's specifications. Customer specific requirements must be approved by Samtec and identified in a Samtec customer-specific drawing to apply.*

BNC7T-J-P-GN-ST-TH1



BNC7T-J-P-GN-ST-EM2



BNC7T-J-C-GN-ST-BH3

**BNC7T SERIES**

# 75 Ω MACHINED BNC JACKS & PLUGS

Mates with:  
RF179, RFA6T,  
RFB6T, GRF7H-C

**SPECIFICATIONS**

For complete specifications and recommended PCB layouts see [www.samtec.com?BNC7T-TH](http://www.samtec.com?BNC7T-TH), [www.samtec.com?BNC7T-BH](http://www.samtec.com?BNC7T-BH) or [www.samtec.com?BNC7T-EM](http://www.samtec.com?BNC7T-EM)

**Shell Material:**  
Ni plated Brass  
**Contact Material:**  
TH1 & BH1 = Copper Alloy  
**Insulator Material:**  
PTFE  
**Impedance:**  
ST = 75 Ω ±2 Ω  
RA = 75 Ω ±4 Ω  
**Frequency Range:**  
0-12 GHz  
**Working Voltage:**  
500 Vrms  
**Dielectric Withstanding:**  
1500 Vrms min  
**Operating Temperature:**  
-65 °C to +125 °C  
**RoHS Compliant:**  
Yes  
**Lead-Free Solderable:** Yes

**Notes:**  
12G-SDI available for PCB mounts only.  
Contact [RFTechnicalGroup@samtec.com](mailto:RFTechnicalGroup@samtec.com) for 12G-SDI PCB mount launch characteristics.  
Designed to meet SMPTE 2082 12G-SDI specifications.

BNC7T	GENDER	TYPE	PLATING	ORIENTATION	TERMINATION
-J = Jack		-P = PCB Mount	-GN = 10 μ" (0.25 μm) Gold contact, 100 μ" (2.54 μm) Nickel shell	-ST = Straight -RA = Right-angle Bulkhead/ Panel Mount	-TH1 = Standard Through-hole -BH1* = Standard Bulkhead Through-hole (-RA only) -EM1* = Edge Mount Bulkhead/Panel Mount for (1.60 mm) .062" PCB (-ST only) -EM2* = Edge Mount Bulkhead/Panel Mount for (2.40 mm) .093" PCB (-ST only)

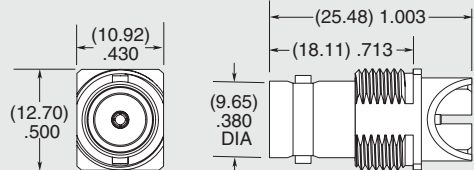

-ST-EM1 & -ST-EM2

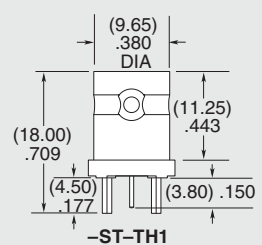

-ST-TH1

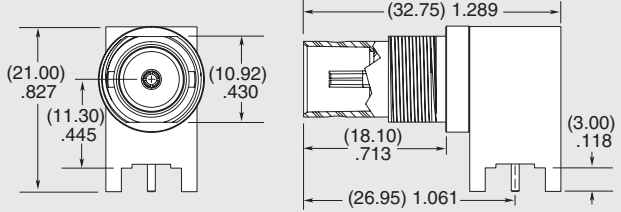

-RA-BH1

\* Lock washers & knurled nuts supplied with Bulkhead/Panel Mount options

**TOOL**

Tool for quickly installing/uninstalling knurl nut for BNC7T Series  
Part Number: TOOL-BNC7T-01

**SPECIFICATIONS**

For complete specifications and assembly instructions see [www.samtec.com?BNC7T-CA](http://www.samtec.com?BNC7T-CA)

**Shell Material:**  
Brass  
**Contact Material:**  
Brass (-P), Copper Alloy (-J)  
**Center Contact:**  
Soldered  
**Outer Ferrule:**  
Crimped  
**Impedance:**  
75 Ω  
**Working Voltage:**  
500 Vrms  
**Dielectric Withstanding:**  
1500 Vrms min  
**Operating Temperature:**  
-65 °C to +125 °C

BNC7T	GENDER	TYPE	PLATING	ORIENTATION	TERMINATION
-P = Plug -J = Jack		-C = Cable	-GN = 10 μ" (0.25 μm) Gold on contact, Nickel on outer contact and shell	-ST = Straight -RA = Right-angle (-P only)	-CA3 = RG 179 Cable (-P only) -CA6 = RG 6 or Belden 1694A Cable (-P only) -BH3 = Bulkhead, RG 179 Cable (-J only)

TERMINATION	C (DIA)
-CA3	(2.70) .106
-CA6	(6.85) .270

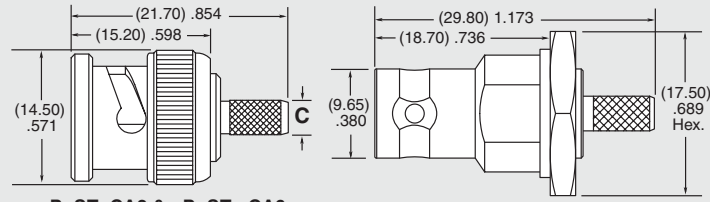

-P-ST-CA3 & -P-ST-CA6

-J-ST-BH3

Supplied with pins, ferrules, washers, nuts and gaskets. See website for dimensions.

Due to technical progress, all designs, specifications and components are subject to change without notice.



# 75 Ω DIE CAST BNC JACKS & PLUGS

Mates with:  
RF179, RFA6T,  
RFB6T, GRF7H-C

## SPECIFICATIONS

For complete specifications and recommended PCB layouts see [www.samtec.com?BNC7T-TH](http://www.samtec.com?BNC7T-TH), [www.samtec.com?BNC7T-BH](http://www.samtec.com?BNC7T-BH), [www.samtec.com?BNC7T-BM](http://www.samtec.com?BNC7T-BM) or [www.samtec.com?BNC7T-EM](http://www.samtec.com?BNC7T-EM)

**Shell Material:** Zinc  
**Contact Material:** Copper Alloy  
**Insulator Material:** PTFE  
**Impedance:**  
ST = 75 Ω ±2 Ω  
RA = 75 Ω ±4 Ω  
**Frequency Range:** 0–12 GHz  
**Working Voltage:** 500 Vrms  
**Dielectric Withstanding:** 1500 Vrms min  
**Operating Temperature:** -65 °C to +125 °C  
**RoHS Compliant:** Yes  
**Lead-Free Solderable:** Yes

## TOOL

Tool for quickly installing/uninstalling knurl nut for BNC7T Series  
Part Number:  
TOOL-BNC7T-01

**Notes:**  
12G-SDI available for PCB mounts only.

Contact [RFTechnicalGroup@samtec.com](mailto:RFTechnicalGroup@samtec.com) for 12G-SDI PCB mount launch characteristics.

Designed to meet SMPTE 2082 12G-SDI specifications.

BNC7T	GENDER	TYPE	PLATING	ORIENTATION	TERMINATION
	-J = Jack	-P = PCB Mount	-GN = 10 μ" (0.25 μm) Gold contact, 100 μ" (2.54 μm) Nickel shell	-ST = Straight  -RA = Right-angle Bulkhead/ Panel Mount	-TH2D = Tall Through-hole Die Cast  -BH2D* = Die Cast Bulkhead Through-hole (-RA only)  -BM1D* = Low Profile Mixed Technology Die Cast Bulkhead for (1.60 mm) .062" PCB (-RA only)  -EM1D* = Edge Mount Die Cast Bulkhead/Panel Mount for (1.60 mm) .062" PCB (-ST only)  -EM2D* = Edge Mount Die Cast Bulkhead/Panel Mount for (2.40 mm) .093" PCB (-ST only)
					* Lock washers & knurled nuts supplied with Bulkhead/Panel Mount options

## SPECIFICATIONS

For complete specifications and assembly instructions see [www.samtec.com?BNC7T-CA](http://www.samtec.com?BNC7T-CA)

**Shell Material:** Zinc  
**Contact Material:** Brass  
**Center Contact:** Soldered  
**Outer Ferrule:** Crimped  
**Impedance:** 75 Ω  
**Working Voltage:** 500 Vrms  
**Dielectric Withstanding:** 1500 Vrms min  
**Operating Temperature:** -65 °C to +125 °C

BNC7T	GENDER	TYPE	PLATING	ORIENTATION	TERMINATION
	-P = Plug	-C = Cable	-GN = 10 μ" (0.25 μm) Gold contact, 100 μ" (2.54 μm) Nickel shell	-ST = Straight	-CA3D = RG 179 Cable Die Cast  -CA6D = RG 6 or Belden 1694A Cable Die Cast

Supplied with pins, ferrules, washers, nuts and gaskets. See website for dimensions.

[WWW.SAMTEC.COM](http://WWW.SAMTEC.COM)

Due to technical progress, all designs, specifications and components are subject to change without notice.

All parts within this catalog are built to Samtec's specifications. Customer specific requirements must be approved by Samtec and identified in a Samtec customer-specific drawing to apply.

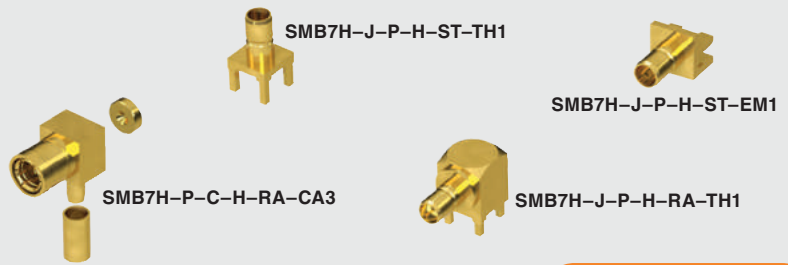

**SMB7H SERIES**

# 75 Ω OPTIMIZED SMB JACKS & PLUGS

**SPECIFICATIONS**

For complete specifications and recommended PCB layouts see [www.samtec.com?SMB7H-TH](http://www.samtec.com?SMB7H-TH) or [www.samtec.com?SMB7H-EM](http://www.samtec.com?SMB7H-EM)

- Shell Material:** Brass
- Contact Material:** Brass
- Insulator Material:** PTFE
- Impedance:** ST = 75 Ω ±3 Ω  
RA = 75 Ω ±4 Ω
- Frequency Range:** 0~4 GHz
- Working Voltage:** 335 Vrms max
- Dielectric Withstanding:** 1000 Vrms min
- Operating Temperature:** -65 °C to +165 °C
- RoHS Compliant:** Yes
- Lead-Free Solderable:** Yes

**SMB7H**

**GENDER**

**TYPE**

**PLATING**

**ORIENTATION**

**TERMINATION**

Mates with:  
RF179, GRF7H-C

**-J**  
= Jack

**-P**  
= PCB Mount

**-H**  
= 30 μ" (0.76 μm)  
Gold center contact,  
3 μ" (0.08 μm)  
Gold outer contact

**-ST**  
= Straight  
**-RA**  
= Right-angle

**-TH1**  
= Through-hole  
(0.90 mm) .035" DIA  
Signal Pin  
**-TH2**  
= Through-hole  
(0.51 mm) .020" DIA  
Signal Pin  
**-EM1**  
= Edge Mount  
(-ST only)

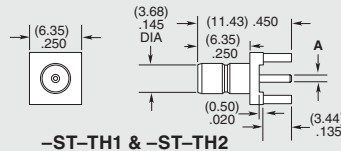
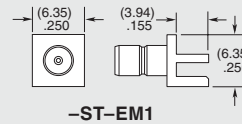
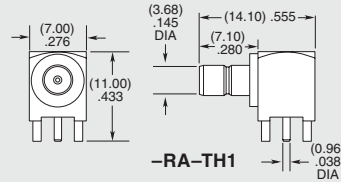

TERMINATION	A (DIA)
-TH1	(0.90) .035
-TH2	(0.51) .020

**SPECIFICATIONS**

For complete specifications and assembly instructions see [www.samtec.com?SMB7H-CA](http://www.samtec.com?SMB7H-CA)

- Shell Material:** Brass
- Contact Material:** BeCu
- Insulator Material:** PTFE
- Center Contact:** Soldered
- Outer Ferrule:** Crimped
- Impedance:** 75 Ω
- Frequency Range:** 0~8 GHz (-ST)  
0~7 GHz (-RA)
- Working Voltage:** 335 Vrms max
- Dielectric Withstanding:** 1000 Vrms min
- Operating Temperature:** -65 °C to +165 °C

**SMB7H**

**GENDER**

**TYPE**

**PLATING**

**ORIENTATION**

**TERMINATION**

**-P**  
= Plug

**-C**  
= Cable

**-H**  
= 30 μ" (0.76 μm)  
Gold center contact,  
3 μ" (0.08 μm)  
Gold outer contact  
(-ST only)

**-ST**  
= Straight  
**-RA**  
= Right-angle

**-CA3**  
= RG 179 Cable

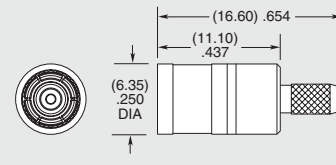
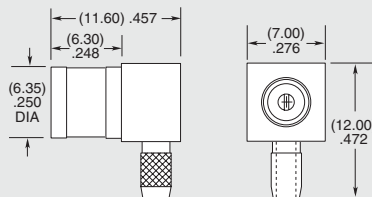

-P-RA

-P-ST

Supplied with pins and ferrules. See website for dimensions.

*Due to technical progress, all designs, specifications and components are subject to change without notice.*

[WWW.SAMTEC.COM](http://WWW.SAMTEC.COM)

All parts within this catalog are built to Samtec's specifications. Customer specific requirements must be approved by Samtec and identified in a Samtec customer-specific drawing to apply.



# ORIGINAL RF SOLUTIONS

## 100 Ω SYSTEMS

Shielded Twisted Pair Twinax Cable (C28S).....	62
Twinax Jack (CJT).....	63

## 75 Ω SYSTEMS

75 Ω Micro-Mini Ganged Cable (GRF7H-C).....	68-69
75 Ω Micro-Mini Ganged Connectors (GRF7-J, GRF7-P) .....	70
75 Ω MMCX Jacks & Plugs (MMCX7).....	72
75 Ω MCX Jacks/Plugs & Cable Components (MCX7).....	73

## 50 Ω SYSTEMS

50 Ω Micro-Mini Ganged Connectors (GRF1-J, GRF1-P) .....	64
50 Ω Micro-Mini Ganged Cable (GRF1-C, GRF1H-C) .....	65-67
50 Ω, 30 AWG Flexible Cable Assembly, (.047" DIA) (RF047) .....	71
50 Ω IsoRate® Cable (IJ5C, IJ5H).....	74-75
50 Ω IsoRate® Connectors (IJ5, IP5) .....	76-77

## APPLICATIONS

Original RF Solutions.....	14
----------------------------	----

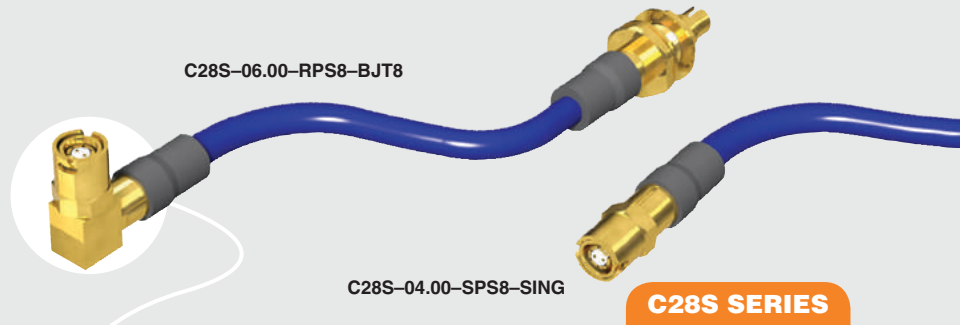

**C28S SERIES**

# 100 Ω CIRCULAR RF TWINAX CABLE

**SPECIFICATIONS**

For complete specifications see [www.samtec.com?C28S](http://www.samtec.com?C28S)

**RF CONNECTOR**

**Outer Contact Material:** Phosphor Bronze (Plug), Brass (Jack)  
**Center Contact Material:** Phosphor Bronze (Terminals), BeCu (Sockets)  
**Insulator Material:** PTFE  
**Operating Temperature:** -40 °C to +85 °C  
**Voltage Rating:** 200 VAC  
**Frequency Range:** 0 - 4 GHz  
**Impedance:** 100 Ω  
**RoHS Compliant:** Yes

Mates with: **CJT, C28S**

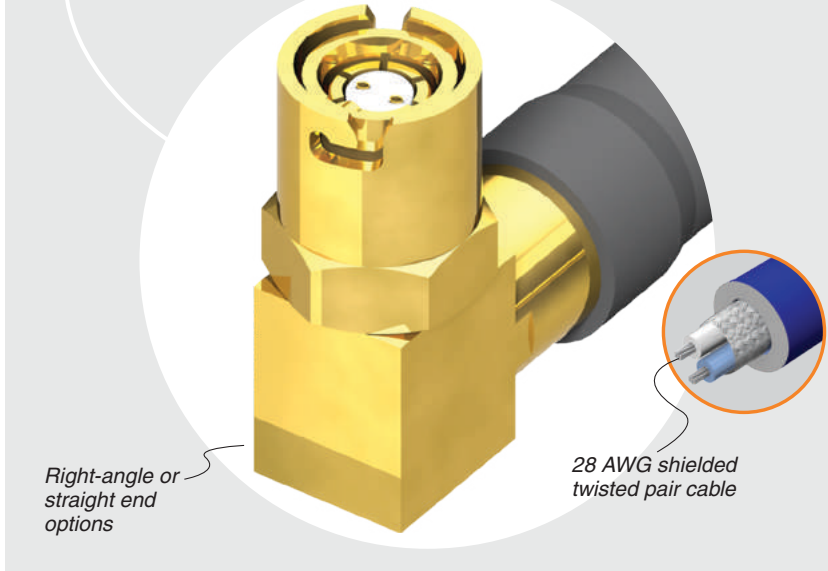

Right-angle or straight end options

28 AWG shielded twisted pair cable

**CABLE**

**Cable:** 28 AWG shielded twisted pair  
**Signal Routing:** 100 Ω Differential  
**Jacket Material:** PVC  
**Insulator Material:** FEP  
**RoHS Compliant:** Yes

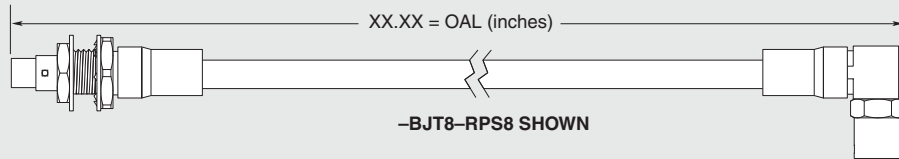
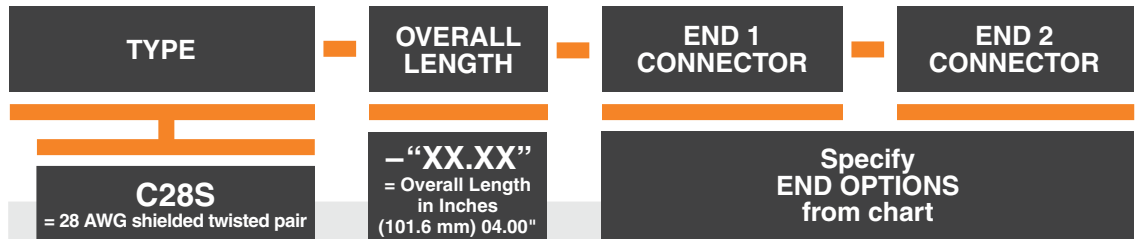

END OPTIONS	
-SPS8 = Straight Plug with Sockets (30 μ" (0.76 μm) Gold on Center and Outer Contact, Gold Flash on Shell)	
-RPS8 = Right-angle Plug with Sockets (30 μ" (0.76 μm) Gold on Center and Outer Contact, Gold Flash on Shell)	
-BJT8 = Bulkhead Jack with Terminals (30 μ" (0.76 μm) Gold on Center and Outer Contact, Gold Flash on Shell)	
-SING = Single Ended (End 2 callout)	
-XXXXXX = Stripped & Tinned (End 2 callout) (See chart for callout)	

STRIPPED & TINNED (Dimensions in inches)			
CALLOUT	A	B	C
-303030	.30	.30	.30
-303040	.30	.30	.40
-403030	.40	.30	.30
-403040	.40	.30	.40

Both center conductors and braid shield are stripped, only the center conductors are tinned.

**ALSO AVAILABLE (MOQ Required)**

- Additional stripping and tinning options  
Contact Samtec.

**Note:** Cable lengths longer than 36.00" (0.92 meter) are not supported with S.I. test data.

Due to technical progress, all designs, specifications and components are subject to change without notice.



CJT-T-P-HH-RA-TH1



CJT-T-P-HH-RA-BH1



**CJT SERIES**

# 100 Ω CIRCULAR RF TWINAX JACK

**SPECIFICATIONS**

For complete specifications and recommended PCB layouts see [www.samtec.com?CJT-TH](http://www.samtec.com?CJT-TH) or [www.samtec.com?CJT-BH](http://www.samtec.com?CJT-BH)

- Shell Material:**  
Brass
- Insulator Material:**  
PTFE
- Contact Material:**  
Phosphor Bronze
- Operating Temperature:**  
-20 °C to +105 °C
- Frequency Range:**  
0 - 4 GHz
- Working Voltage:**  
200 VAC
- Impedance:**  
100 Ω
- RoHS Compliant:**  
Yes
- Lead-Free Solderable:**  
Yes

**Mates with:**  
C28S

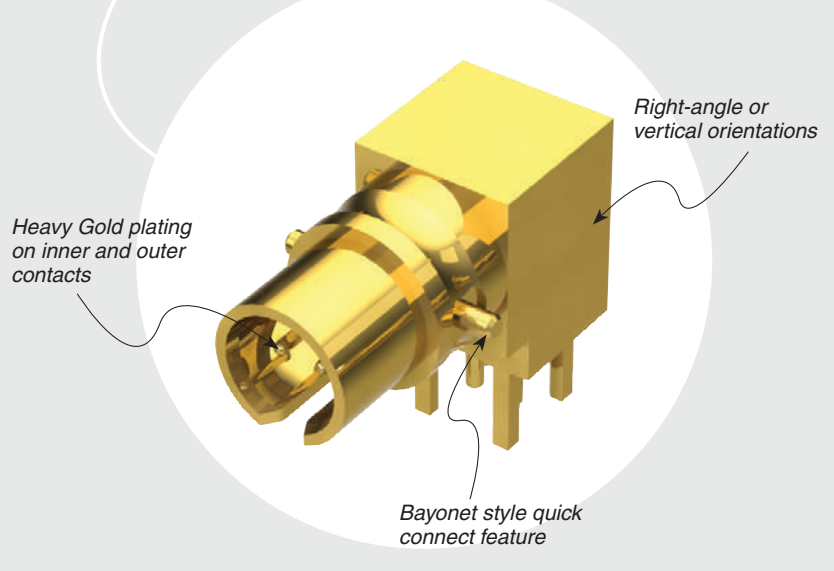

CJT	GENDER	TYPE	PLATING	ORIENTATION	TERMINATION
-T		-P = PCB Mount	-HH = 30 μ" (0.76 μm) Gold on pins and outer contact	-ST = Straight -RA = Right-angle	-TH1 = Standard Through-hole -BH1* = Standard Bulkhead Through-hole (-RA only)

**-ST-TH1** dimensions: (0.70) .028 DIA, (1.27) .050, (6.35) .250, (4.70) .185 DIA, (10.01) .394, (7.31) .288, (9.76) .384, (0.51) .020

**-RA-TH1** dimensions: (3.15) .124 DIA, (9.05) .356, (6.35) .250, (8.81) .347, (2.54) .100, (10.86) .428, (3.30) .130, (3.70) .146

**-RA-BH1\*** dimensions: (10.60) .417 DIA, (18.86) .743, (2.54) .100

\* Lock washer, nut and gasket supplied unassembled with Bulkhead option.

Due to technical progress, all designs, specifications and components are subject to change without notice.

[WWW.SAMTEC.COM](http://WWW.SAMTEC.COM)

All parts within this catalog are built to Samtec's specifications. Customer specific requirements must be approved by Samtec and identified in a Samtec customer-specific drawing to apply.

GRF1-P-P-08-E-ST-TH1

GRF1-P-P-04-E-ST-TH1

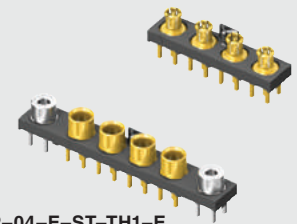
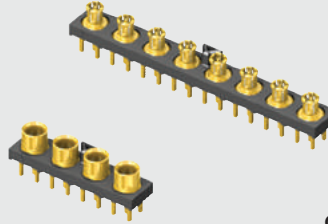

GRF1-J-P-04-E-ST-TH1

GRF1-J-P-04-E-ST-TH1-E

GRF1-J, GRF1-P SERIES

(5.00 mm) .197"

# 50 Ω GANGED MICRO-MINI RF SYSTEMS

## SPECIFICATIONS

For complete specifications and recommended PCB layouts see [www.samtec.com?GRF1-J](http://www.samtec.com?GRF1-J) or [www.samtec.com?GRF1-P](http://www.samtec.com?GRF1-P)

**Shell Material:**

Brass

**Insulator Material:**

PTFE

**Contact Material:**

BeCu

**Pin Material:**

Brass

**Plating:**

30 μ" (0.76 μm) Au

over 50 μ" (1.27 μm) Ni

**Current Rating**

(GRF1-J/GRF1-P):

Signals: 3.6 A per pin

(8 adjacent pins powered)

Grounds: 6.2 A per pin

(8 adjacent pins powered)

**Operating Temp Range:**

-40 °C to +90 °C

**Impedance:**

50 Ω

**Dielectric**

**Withstanding Voltage:**

500 Vrms, 50 Hz

**Dielectric Working Voltage:**

170 Vrms, 50 Hz

**Frequency Range:**

0-6 GHz

**RoHS Compliant:**

Yes

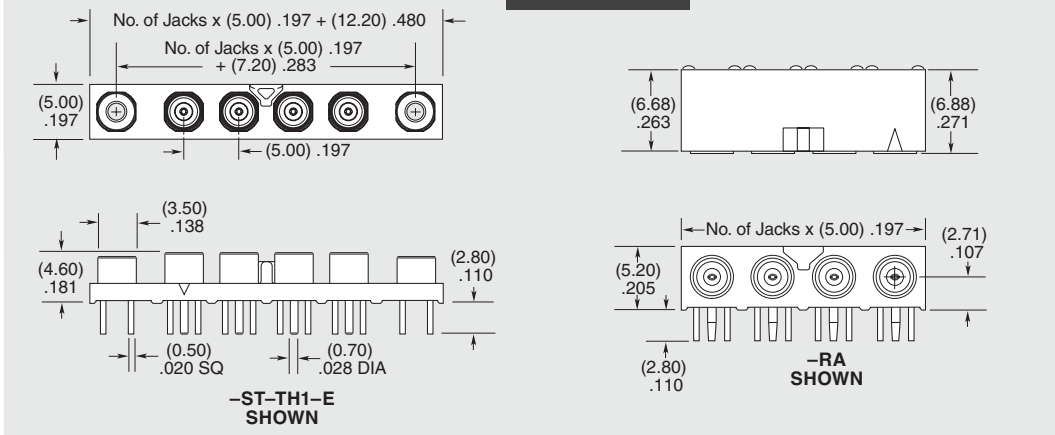
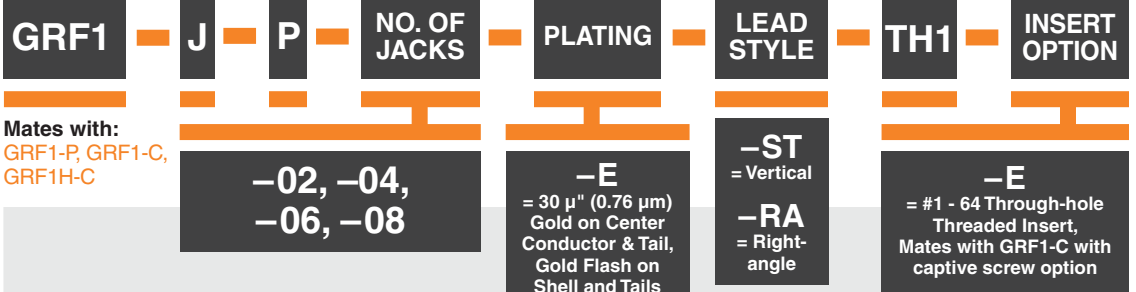

## PROCESSING

**Lead-Free Solderable:**

Yes

## RECOGNITIONS

For complete scope of recognitions see [www.samtec.com/quality](http://www.samtec.com/quality)



FILE NO. E111594

## APPLICATION

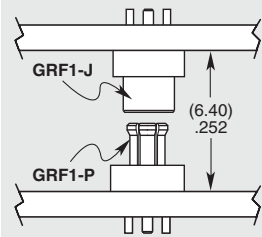

## OTHER SOLUTIONS

- Cable assembly (see GRF1-C Series)

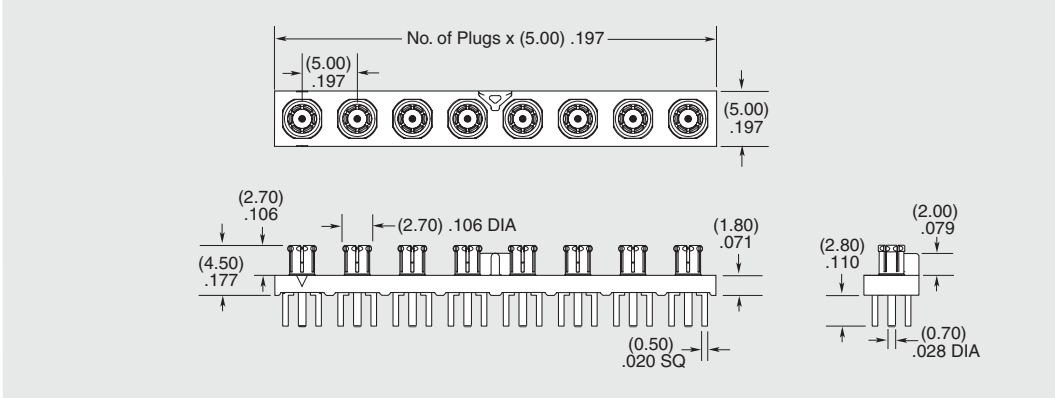
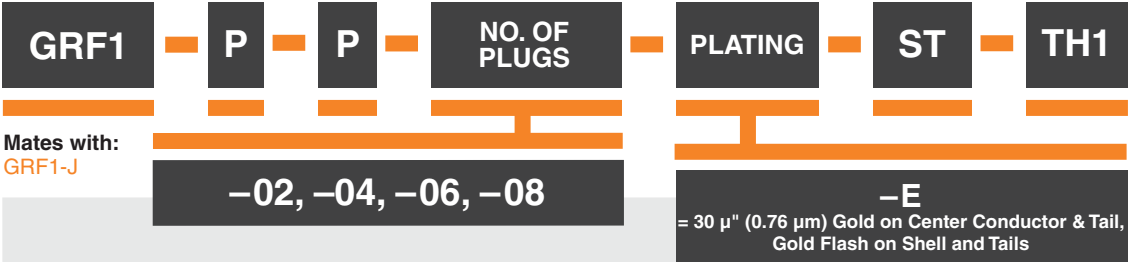

Due to technical progress, all designs, specifications and components are subject to change without notice.



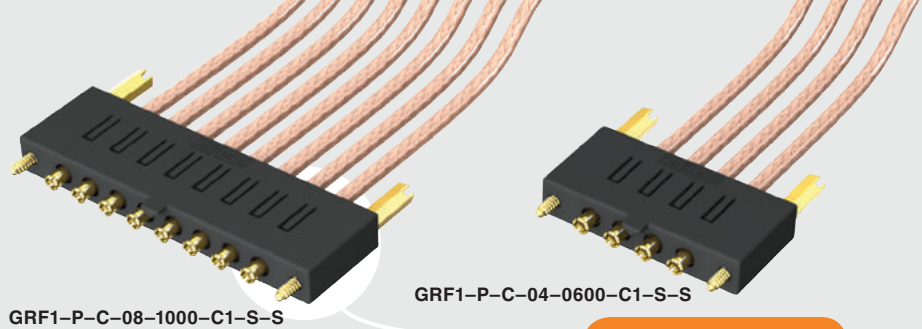

**GRF1-C SERIES**

**(5.00 mm) .197"**

# 50 Ω GANGED MICRO-MINI RF CABLE

## SPECIFICATIONS

For complete specifications see [www.samtec.com?GRF1-C](http://www.samtec.com?GRF1-C)

- Shell Material:** Brass
- Insulator Material:** PTFE
- Contact Material:** BeCu
- Pin Material:** Brass
- Plating:** 30 μ" (0.76 μm) Au over 50 μ" (1.27 μm) Ni
- Operating Temp Range:** -40 °C to +90 °C
- Impedance:** 50 Ω
- RoHS Compliant:** Yes

- RG 316 Cable:**
- Impedance:** 50 Ω
- Capacitance:** 96.432 pF/meter
- Propagation Delay:** 4.83 nsec/meter
- Max Attenuation (cable only):** 1.25 dB @ 1 GHz for 1 meter
- Conductor Size:** 26 AWG, (0.51 mm) .020" dia.
- Conductor Material:** Silver Plated Copper
- Insulator Diameter:** (1.52 mm) .060"
- Insulator Material:** PTFE
- Shield Material:** Silver Plated Copper Clad Steel
- Jacket Material:** FEP
- Jacket Diameter:** (2.54 mm) .100"
- Jacket Color:** Amber
- Bend Radius:** 12.7 mm
- RoHS Compliant:** Yes

**Mates with:**  
 GRF1-J

**TOOLING**  
 Application Tooling.  
 Contact atg@samtec.com for more information.

**OTHER SOLUTIONS**  
 • 50 Ω Board-to-Board system (see GRF1-J & GRF1-P Series)

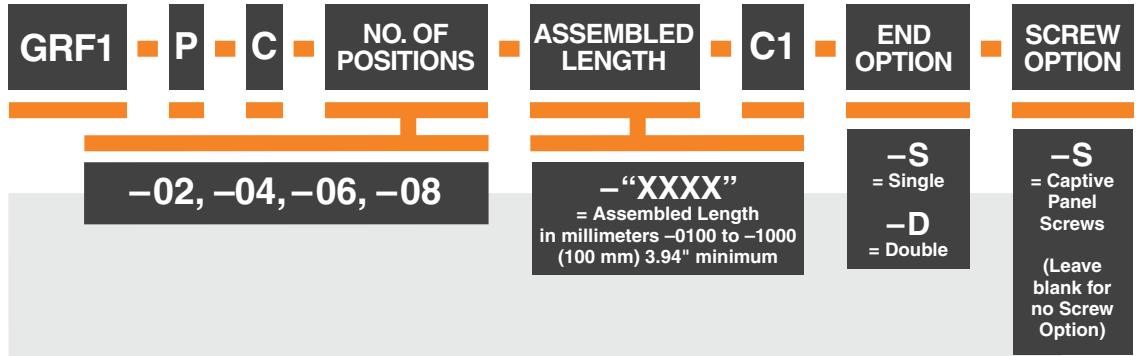
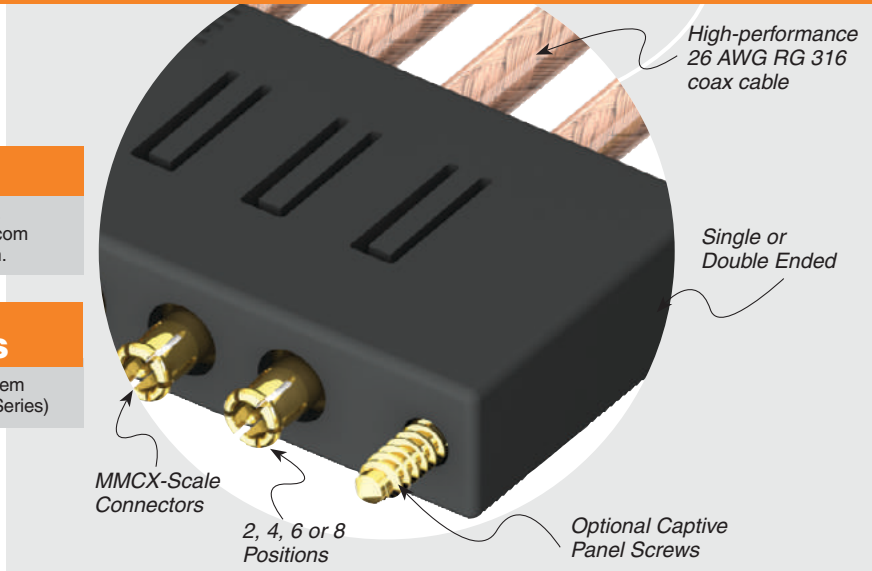

## RECOGNITIONS

For complete scope of recognitions see [www.samtec.com/quality](http://www.samtec.com/quality)



**Notes:**  
 Cable lengths longer than 40.00" (1 meter) are not supported with S.I. test data.  
 This Series is non-standard, non-returnable.

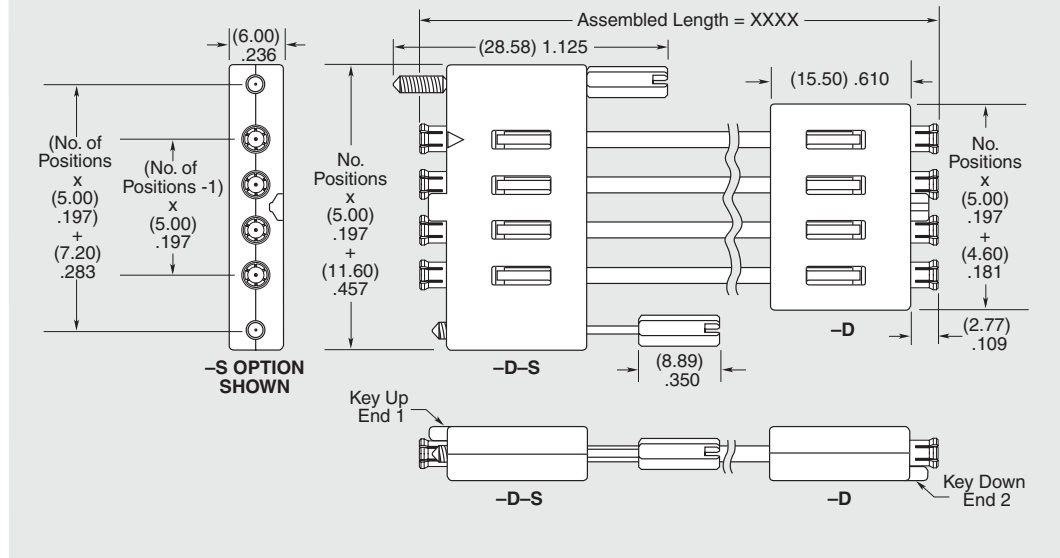

*Due to technical progress, all designs, specifications and components are subject to change without notice.*

[WWW.SAMTEC.COM](http://WWW.SAMTEC.COM)

All parts within this catalog are built to Samtec's specifications.  
 Customer specific requirements must be approved by Samtec and identified in a Samtec customer-specific drawing to apply.

GRF1H-4-0300-1-CA1-S-02SP1

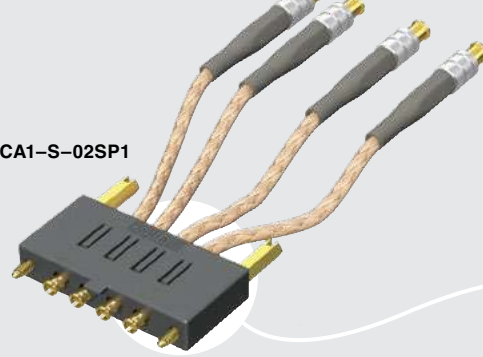

(5.00 mm) .197"

# 50 Ω HYBRID MICRO-MINI RF CABLE

## SPECIFICATIONS

For complete specifications see [www.samtec.com?GRF1H-C](http://www.samtec.com?GRF1H-C)

### RF Connector:

**Shell Material:**  
Brass  
(GRF, SMA, MCX, MMCX, SMB, BNC)  
**Insulator Material:**  
PTFE  
**Contact Material:**  
Brass  
(GRF, SMA, MCX, MMCX, SMB-J, BNC-P, TNC-P)  
Phosphor Bronze  
(SMB-P-ST, TNC-J, N Type)  
BeCu  
(SMB-P-RA)  
Copper Alloy  
(BNC-J)

**Operating Temp Range:**  
-40 °C to +90 °C

**Impedance:**  
50 Ω

**RoHS Compliant:**  
Yes

### RG 316 Cable:

**Impedance:**  
50 Ω  
**Capacitance:**  
96.432 pF/meter  
**Propagation Delay:**  
4.83 nsec/meter  
**Max Attenuation (cable only):**  
1.25 dB @ 1 GHz for 1 meter  
**Conductor Size:**  
26 AWG,  
(0.51 mm) .020" dia.  
**Conductor Material:**  
Silver Plated Copper  
**Insulator Material:**  
PTFE  
**Shield Material:**  
Silver Plated  
Copper Clad Steel  
**Jacket Material:**  
FEP  
**Jacket Diameter:**  
(2.54 mm) .100"  
**Jacket Color:**  
Amber  
**Bend Radius:**  
12.7 mm  
**RoHS Compliant:**  
Yes

**Mates with:**  
GRF1-J, SMA,  
MCX, SMB5, MMCX,  
BNC5, TNC, NTPE

High-performance  
26 AWG RG 316  
coax cable

2, 4, 6 or 8  
Positions

MMCX-Scale  
Connectors

Optional Captive  
Panel Screws

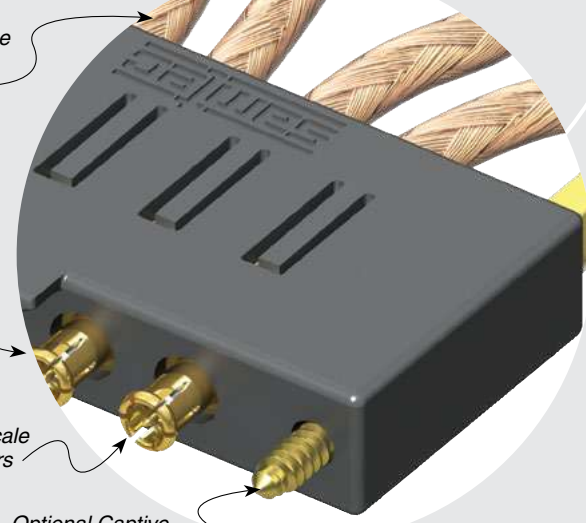

GRF1H

NO. OF  
POSITIONS

ASSEMBLED  
LENGTH

-2, -4, -6, -8

- "XXXX"

= Assembled Length in millimeters  
-0100 (0100 mm) 3.94" minimum

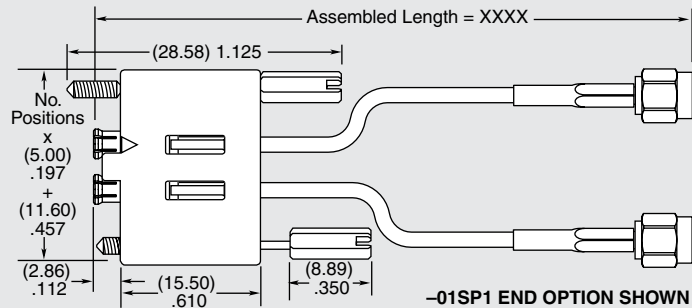
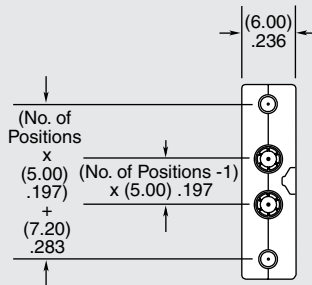

-01SP1 END OPTION SHOWN

## RECOGNITIONS

For complete scope of recognitions see [www.samtec.com/quality](http://www.samtec.com/quality)



**Notes:**  
Cable lengths longer than 40.00" (1 meter) are not supported with S.I. test data.

This series is non-standard, non-returnable.

END OPTIONS		END OPTIONS	
-01SP1 = SMA Straight Plug (30 μ" (0.76 μm) Gold on Center Contact, Gold Flash on Shell)		-07SP1 = SMB Straight Plug (30 μ" (0.76 μm) Gold on Center Contact, Gold Flash on Shell)	
-01RP1 = SMA Right-angle Plug (30 μ" (0.76 μm) Gold on Center Contact, Gold Flash on Shell)		-07RP1 = SMB Right-angle Plug (30 μ" (0.76 μm) Gold on Center Contact, Gold Flash on Shell)	
-01PN1 = SMA Straight Panel Mount Jack (30 μ" (0.76 μm) Gold on Center Contact, Gold Flash on Shell)		-02SJ1 = MCX Straight Jack (30 μ" (0.76 μm) Gold on Center Contact, Gold Flash on Shell)	

Due to technical progress, all designs, specifications and components are subject to change without notice.

[WWW.SAMTEC.COM](http://WWW.SAMTEC.COM)

All parts within this catalog are built to Samtec's specifications.

Customer specific requirements must be approved by Samtec and identified in a Samtec customer-specific drawing to apply.

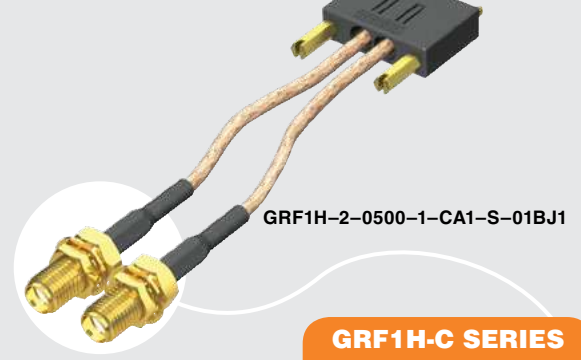

**GRF1H-C SERIES**

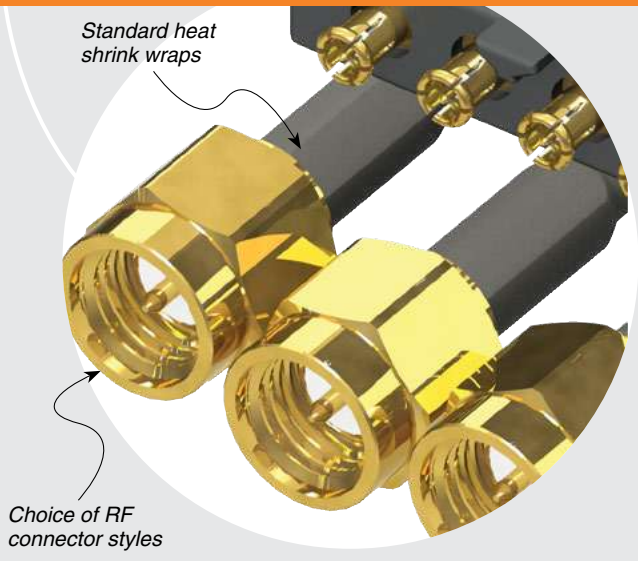

**END 1 PLATING**

**-1**  
= All Gold components

**CABLE TYPE**

**-CA1**  
= RG 316 cable

**SCREW OPTION**

**-S**  
= Captive Panel Screws  
(Leave blank for no Screw Option)

**END 2 OPTION**

Specify END OPTIONS from chart

END OPTIONS		END OPTIONS		END OPTIONS	
<p><b>-02SP1 = MCX</b> Straight Plug (30 μ" (0.76 μm) Gold on Center Contact, Gold Flash on Shell)</p>		<p><b>-05SP3 = TNC</b> Straight Plug (10 μ" (0.25 μm) Gold on Center Contact, Nickel on Shell)</p>		<p><b>-07BJ1 = SMB</b> Straight Bulkhead Jack (30 μ" (0.76 μm) Gold on Center Contact, Gold Flash on Shell)</p>	
<p><b>-02RP1 = MCX</b> Right-angle Plug (30 μ" (0.76 μm) Gold on Center Contact, Gold Flash on Shell)</p>		<p><b>-01BJ1 = SMA</b> Straight Bulkhead Jack <b>-01BR1 = SMA</b> Straight Bulkhead Jack, Reversed Polarity <b>-01SB1 = SMA</b> Straight Bulkhead Jack, Sealed <b>-01SR1 = SMA</b> Straight Bulkhead Jack, Sealed, Reversed Polarity (30 μ" (0.76 μm) Gold on Center Contact, Gold Flash on Shell)</p>		<p><b>-04BJ2 = BNC</b> Straight Bulkhead Jack (30 μ" (0.76 μm) Gold on Center Contact, Nickel on Shell)</p>	
<p><b>-03SP1 = MMCX</b> Straight Plug (30 μ" (0.76 μm) Gold on Center Contact, Gold Flash on Shell)</p>				<p><b>-05BJ3 = TNC</b> Straight Bulkhead Jack (10 μ" (0.25 μm) Gold on Center Contact, Nickel on Shell)</p>	
<p><b>-03RP1 = MMCX</b> Right-angle Plug (30 μ" (0.76 μm) Gold on Center Contact, Gold Flash on Shell)</p>				<p><b>-06BJ2 = N Type</b> Straight Bulkhead Jack (30 μ" (0.76 μm) Gold on Center Contact, Nickel on Shell)</p>	
<p><b>-04SP3 = BNC</b> Straight Plug (10 μ" (0.25 μm) Gold on Center Contact, Nickel on Shell)</p>					

Due to technical progress, all designs, specifications and components are subject to change without notice.

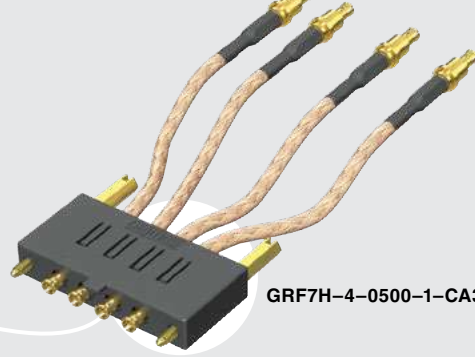

GRF7H-4-0500-1-CA3-S-73SP1

(5.00 mm) .197"

# 75 Ω HYBRID MICRO-MINI RF CABLE

## SPECIFICATIONS

For complete specifications see [www.samtec.com?GRF7H-C](http://www.samtec.com?GRF7H-C)

### RF Connector:

**Shell Material:**  
Brass  
(GRF, MCX, SMB, DIN, BNC, MMCX7-J)  
BeCu  
(MMCX7-P)

**Insulator Material:**  
PTFE

**Contact Material:**  
BeCu  
(GRF, SMB)  
Brass  
(MCX, BNC-P, MMCX7)  
Copper Alloy  
(DIN, BNC-J)

**Operating Temp Range:**  
-40 °C to +90 °C

**Impedance:**  
75 Ω

**RoHS Compliant:**  
Yes

### RG 179 Cable:

**Impedance:**  
75 Ω ±3 Ω  
**Capacitance:**  
64 pF/meter  
**Max Attenuation (cable only):**  
0.8 dB @ 1 GHz for 1 meter  
**Conductor Size:**  
30 AWG, (0.31 mm) .012" dia.

**Conductor Material:**  
Silver Plated Copper

**Insulator Material:**  
PTFE

**Shield Material:**  
Silver Plated Copper

**Jacket Material:**  
FEP

**Jacket Diameter:**  
(2.54 mm) .100"

**Jacket Color:**  
Amber

**Bend Radius:**  
10.2 mm

**RoHS Compliant:**  
Yes

### Mates with:

GRF7-J, MCX7, MMCX7, SMB7H, DIN7A, BNC7T

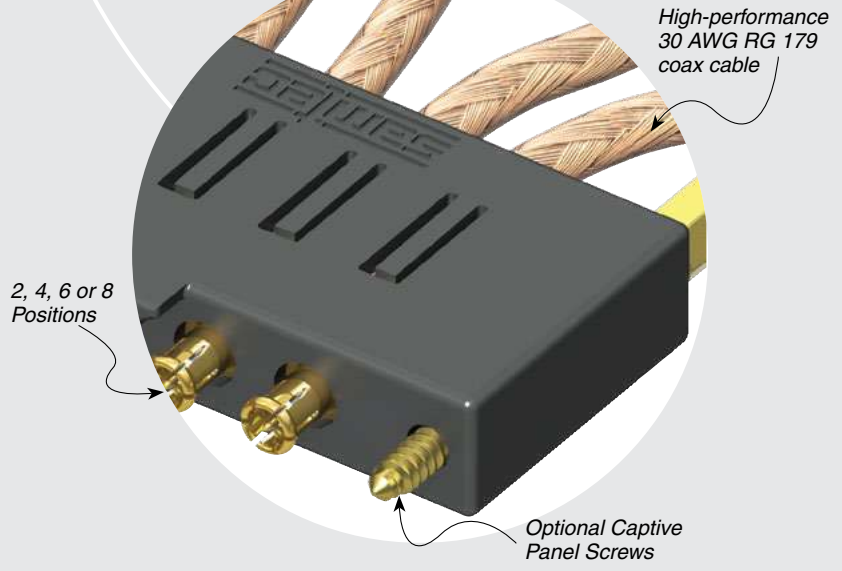

GRF7H

NO. OF POSITIONS

ASSEMBLED LENGTH

-2, -4, -6, -8

- "XXXX"

= Assembled Length in millimeters  
-0100 (100 mm) 3.94" minimum

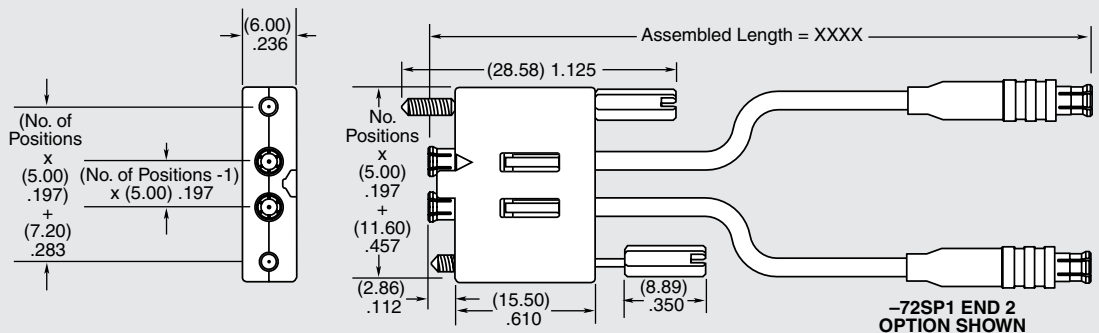

## RECOGNITIONS

For complete scope of recognitions see [www.samtec.com/quality](http://www.samtec.com/quality)



**Notes:**  
Cable lengths longer than 40.00" (1 meter) are not supported with S.I. test data.

This series is non-standard, non-returnable.

END OPTIONS		END OPTIONS	
-73SP1 = 75 Ω MMCX7 Straight Plug (30 μ" (0.76 μm) Gold on Center Contact, Gold Flash on Shell)		-72SP1 = 75 Ω MCX Straight Plug (30 μ" (0.76 μm) Gold on Center Contact, Gold Flash on Shell)	
-73SJ1 = 75 Ω MMCX7 High Vibration Straight Jack (30 μ" (0.76 μm) Gold on Center Contact, Gold Flash on Shell)		-72RP1 = 75 Ω MCX Right-angle Plug (30 μ" (0.76 μm) Gold on Center Contact, Gold Flash on Shell)	

Due to technical progress, all designs, specifications and components are subject to change without notice.

[WWW.SAMTEC.COM](http://WWW.SAMTEC.COM)

All parts within this catalog are built to Samtec's specifications. Customer specific requirements must be approved by Samtec and identified in a Samtec customer-specific drawing to apply.



GRF7H-2-0300-1-CA3-S-74BJ3



GRF7H-4-0800-1-CA3-73SJ1

**GRF7H-C SERIES**



Variety of standard straight and right-angle plugs and jacks

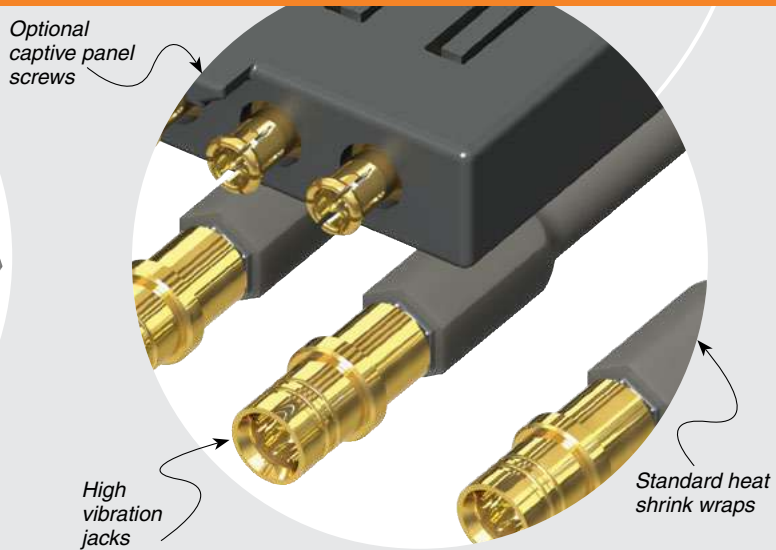

Optional captive panel screws

High vibration jacks

Standard heat shrink wraps

**END 1 PLATING**

-1

= All Gold components

**CABLE TYPE**

-CA3

= RG 179 cable

**SCREW OPTION**

-S

= Captive Panel Screws  
(Leave blank for no Screw Option)

**END 2 OPTION**

Specify END OPTIONS from chart

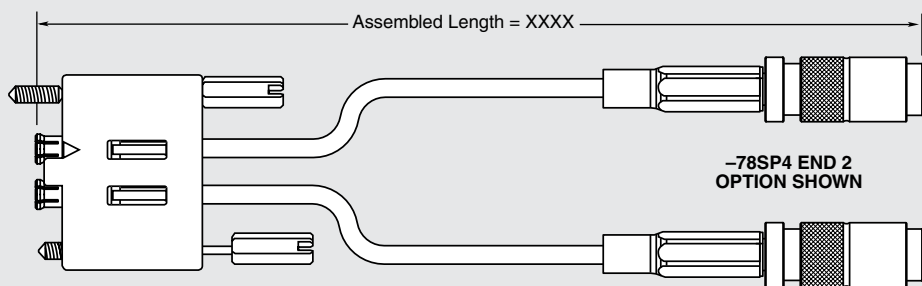

END OPTIONS	
-77RP1 = 75 Ω SMB Right-angle Plug (30 μ" (0.76 μm) Gold on Center Contact, Gold Flash on Shell)	
-77SP1 = 75 Ω SMB Straight Plug (30 μ" (0.76 μm) Gold on Center Contact, Gold Flash on Shell)	
-78SP4 = 75 Ω DIN Straight Plug (10 μ" (0.25 μm) Gold on Center Contact, Nickel on Shell)	

END OPTIONS	
-74BJ3 = 75 Ω BNC Straight Bulkhead Jack (10 μ" (0.25 μm) Gold on Center Contact, Nickel on Shell)	
-74SP3* = 75 Ω BNC Straight Plug (10 μ" (0.25 μm) Gold on Center Contact, Nickel on Shell)  (*Die Cast also available = -D4SP3)	

Due to technical progress, all designs, specifications and components are subject to change without notice.

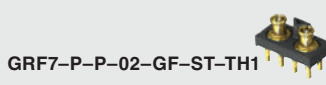

GRF7-P-P-02-GF-ST-TH1

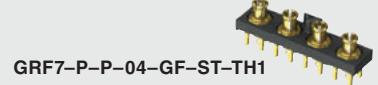

GRF7-P-P-04-GF-ST-TH1

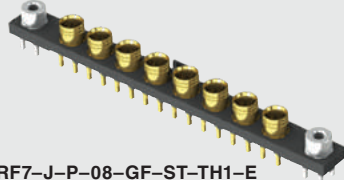

GRF7-J-P-08-GF-ST-TH1-E

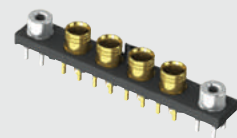

GRF7-J-P-04-GF-ST-TH1-E

**GRF7-J, GRF7-P SERIES**

**(5.00 mm) .197"**

# 75 Ω GANGED MICRO-MINI RF SYSTEMS

## SPECIFICATIONS

For complete specifications and recommended PCB layouts see [www.samtec.com?GRF7-J](http://www.samtec.com?GRF7-J) or [www.samtec.com?GRF7-P](http://www.samtec.com?GRF7-P)

- Housing Material:** ABS
- Shell Material:** Brass
- Insulator Material:** PTFE
- Contact Material:** BeCu
- Pin Material:** Brass
- Operating Temp Range:** -55 °C to +125 °C
- Impedance:** 75 Ω
- Dielectric Withstanding Voltage:** 500 Vrms, 50 Hz
- Dielectric Working Voltage:** 170 Vrms, 50 Hz
- Frequency Range:** 0-6 GHz
- RoHS Compliant:** Yes

## PROCESSING

**Lead-Free Solderable:** Yes

## RECOGNITIONS

For complete scope of recognitions see [www.samtec.com/quality](http://www.samtec.com/quality)



FILE NO. E111594

## APPLICATION

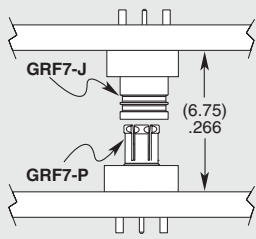

## OTHER SOLUTIONS

- Cable assembly (see GRF7H-C Series)

<b>GRF7</b>	<b>J</b>	<b>P</b>	<b>NO. OF JACKS</b>	<b>PLATING</b>	<b>LEAD STYLE</b>	<b>TH1</b>	<b>INSERT OPTION</b>
Mates with: GRF7-P, GRF7H-C			<b>-02, -04, -06, -08</b>	<b>-GF</b> = 10 μ" (0.25 μm) Gold center contact, 3 μ" (0.08 μm) Gold outer contact	<b>-ST</b> = Vertical <b>-RA</b> = Right-angle	<b>-E</b> = #1 - 64 Through-hole Threaded Insert, Mates with GRF7-C with captive screw option	

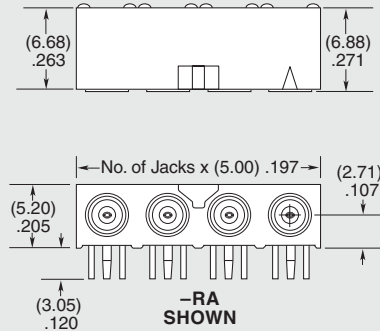
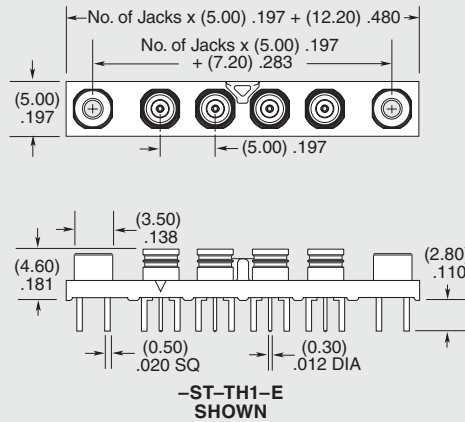

<b>GRF7</b>	<b>P</b>	<b>P</b>	<b>NO. OF PLUGS</b>	<b>PLATING</b>	<b>ST</b>	<b>TH1</b>
Mates with: GRF7-J			<b>-02, -04, -06, -08</b>	<b>-GF</b> = 10 μ" (0.25 μm) Gold center contact, 3 μ" (0.08 μm) Gold outer contact		

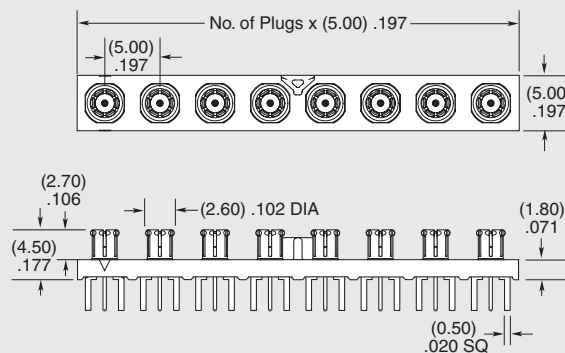

Due to technical progress, all designs, specifications and components are subject to change without notice.



RF047-11RP9-11SP9-0100



RF047-01SP1-11SP9-0100

**RF047 SERIES**

# 50 Ω .047" DIA FLEXIBLE CABLE

**SPECIFICATIONS**

For complete specifications see [www.samtec.com?RF047](http://www.samtec.com?RF047)

**RF Connector:**

**Outer Contact Material:**  
Brass (SMA),  
BeCu (HMHF1)

**Contact Material:**  
Brass (SMA),  
BeCu (HMHF1)

**Insulator Material:**  
PTFE

**Impedance:**  
50 Ω

**Frequency Range:**  
0~10 GHz (HMHF1)  
0~20 GHz (SMA)

**Dielectric Withstanding:**  
1,000 Vrms (SMA)

**CCA-047 (.047")**

**Cable:**

**Impedance:**  
50 Ω microwave

**Capacitance:**  
95.14 pF/meter

**Max Attenuation (cable only):**  
1.15 @ 1 GHz for 1 meter

**Conductor Size:**  
28 AWG (0.29 mm) .011" dia.

**Conductor Material:**  
Silver plated copper

**Insulator Material:**  
FEP

**Shield Material:**  
Metallic Alloy

**Jacket Material:**  
FEP

**Jacket Diameter:**  
(1.42 mm) .056" dia.

**Bend Radius:**  
5 mm

**Mates with:**  
SMA, RSP-122811-01

A Samtec original solution:  
**U.FL compatible plug to 500 cycles (HMHF1)**

**MATING SOLUTION**

- Micro RF PCB connectors for Micro High Frequency RFs
- MHF1 end mates with RSP-122811-01 (Cycles: 30 max.)

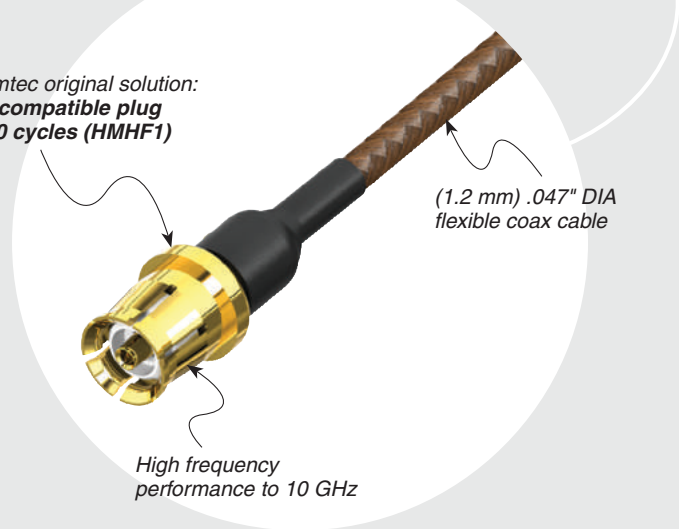
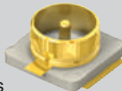

**CABLE TYPE**

**END 1 CONNECTOR**

**END 2 CONNECTOR**

**OVERALL LENGTH**

**RF047**  
= (1.2 mm) .047" DIA  
28 AWG Flexible coax cable

Specify END OPTIONS from chart

– “XXXX”  
= Overall Length in millimeters  
–0100 (100 mm) 3.94" minimum

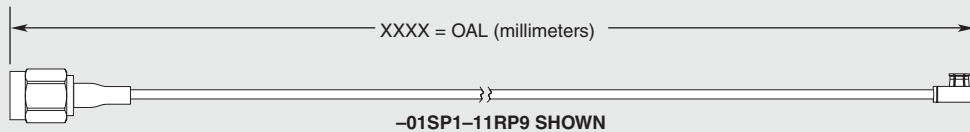

**ALSO AVAILABLE (MOQ Required)**

- Additional stripping and tinning options
- Contact Samtec.

**OTHER SOLUTIONS**

- Cable connector kits (see cable components catalog pages)

**END OPTIONS**

<p>–01SP1 = SMA Straight Plug (30 μ" (0.76 μm) Gold on Center Contact, Gold Flash on Shell)</p>	
<p>–11SP9 = HMHF1 U.FL Straight Plug (30 μ" (0.76 μm) Gold on Center Contact, Gold Flash on Shell)</p>	
<p>–11RP9 = HMHF1 U.FL Right-angle Plug (30 μ" (0.76 μm) Gold on Center Contact, Gold Flash on Shell)</p>	
<p>–SING = Single Ended (End 2 Callout)</p>	
<p>–XXXXXX = Stripped &amp; Tinned (End 2 Callout)</p>	

**STRIPPED & TINNED (Dimensions in mm)**

CALLOUT	A	B	C
–303030	3.0	3.0	3.0
–303040	3.0	3.0	4.0
–403030	4.0	3.0	3.0
–403040	4.0	3.0	4.0
–404040	4.0	4.0	4.0

Both center conductor and braid shield are stripped, only the center conductor is tinned.

MMCX7-J-P-GF-RA-TH1



MMCX7-J-P-GF-ST-TH1



MMCX7-P-P-GF-ST-TH1

**MMCX7 SERIES**

# 75 Ω MICRO-MINI SYSTEMS

**SPECIFICATIONS**

For complete specifications and recommended PCB layouts see [www.samtec.com?MMCX7-TH](http://www.samtec.com?MMCX7-TH)

- Shell Material:** Brass
- Insulator Material:** PTFE
- Contact Material:** BeCu
- Pin Material:** Brass
- Operating Temp Range:** -65 °C to +125 °C
- Impedance:** 75 Ω
- Dielectric Withstanding Voltage:** 500 Vrms, 50 Hz
- Dielectric Working Voltage:** 170 Vrms, 50 Hz
- Frequency Range:** 0-6 GHz
- RoHS Compliant:** Yes

**PROCESSING**

**Lead-Free Solderable:** Yes

**MMCX7**

**GENDER**

**TYPE**

**PLATING**

**ORIENTATION**

**TERMINATION**

**Mates with:**  
MMCX7-P, RF179,  
GRF7H-C

**-J**  
= Jack

**-P**  
= PCB Mount

**-GF**  
= 10 μ" (0.25 μm) Gold center contact,  
3 μ" (0.08 μm) Gold outer contact

**-RA**  
= Right-angle

**-ST**  
= Straight

**-TH1**  
= Through-hole

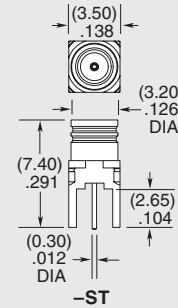
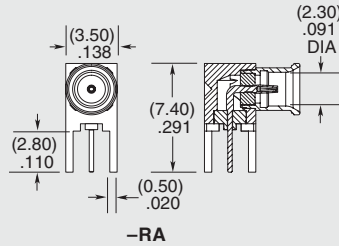

**OTHER SOLUTIONS**

- 75 Ω Cable Components available
- Contact Samtec.

**MMCX7**

**GENDER**

**TYPE**

**PLATING**

**ST**

**TH1**

**Mates with:**  
MMCX7-J, RF179,  
GRF7H-C

**-P**  
= Plug

**-P**  
= PCB Mount

**-GF**  
= 10 μ" (0.25 μm) Gold center contact,  
3 μ" (0.08 μm) Gold outer contact

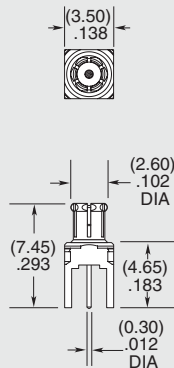

*Due to technical progress, all designs, specifications and components are subject to change without notice.*



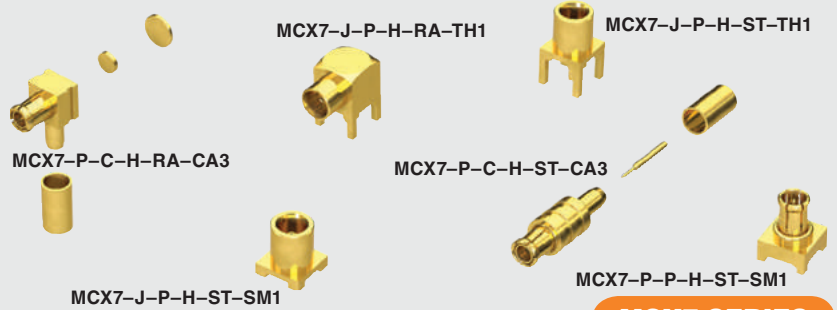

**MCX7 SERIES**

# 75 Ω OPTIMIZED MCX JACKS & PLUGS

**SPECIFICATIONS**

For complete specifications and recommended PCB layouts see [www.samtec.com?MCX7-SM](http://www.samtec.com?MCX7-SM) or [www.samtec.com?MCX7-TH](http://www.samtec.com?MCX7-TH)

- Shell Material:** Brass
- Contact Material:** BeCu
- Insulator Material:** PTFE
- Impedance:** ST = 75 Ω ±3 Ω  
RA = 75 Ω ±4 Ω
- Frequency Range:** 0-6 GHz
- Working Voltage:** 170 Vrms max
- Dielectric Withstanding:** 500 Vrms min
- Engagement Force:** 4.5 lbs max (-ST only)
- Disengagement Force:** 2.3 lbs max (-ST only)
- Operating Temperature:** -65 °C to +125 °C
- RoHS Compliant:** Yes

**PROCESSING**

**Lead-Free Solderable:** Yes

**MCX7**

**GENDER**

**TYPE**

**PLATING**

**ORIENTATION**

**TERMINATION**

Mates with:  
RF179,  
GRF7H-C

**-P**  
= Plug  
**-J**  
= Jack

**-P**  
= PCB  
Mount

**-H**  
= 30 μ" (0.76 μm)  
Gold center  
contact,  
3 μ" (0.08 μm)  
Gold outer  
contact

**-ST**  
= Straight  
**-RA**  
= Right-angle  
(-J-TH1 only)

**-SM1**  
= Surface Mount  
(-ST only)  
**-TH1**  
= Through-hole  
(-J only)

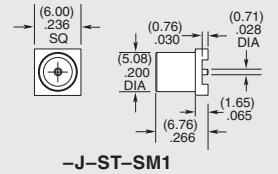

**-J-ST-SM1**

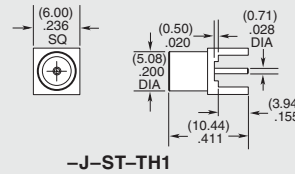

**-J-ST-TH1**

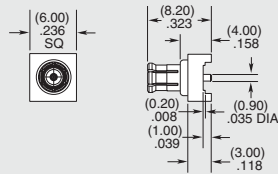

**-P-ST-SM1**

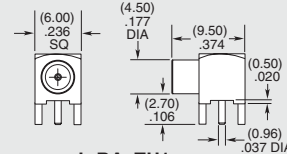

**-J-RA-TH1**

**SPECIFICATIONS**

For complete specifications and assembly instructions see [www.samtec.com?MCX7-CA](http://www.samtec.com?MCX7-CA)

- Contact Material:** Brass
- Finger Shell Material:** BeCu
- Body Material:** Brass
- Insulator Material:** PTFE
- Center Contact:** Soldered
- Outer Ferrule:** Crimped
- Impedance:** 75 Ω
- Frequency Range:** 0-6 GHz (-ST)  
0-4.5 GHz (-RA)
- Working Voltage:** 170 Vrms max
- Dielectric Withstanding:** 500 Vrms min
- Operating Temperature:** -65 °C to +125 °C

**MCX7**

**GENDER**

**TYPE**

**PLATING**

**ORIENTATION**

**TERMINATION**

**-P**  
= Plug

**-C**  
= Cable

**-H**  
= 30 μ" (0.76 μm)  
Gold center  
contact,  
3 μ" (0.08 μm)  
Gold outer  
contact

**-ST**  
= Straight  
**-RA**  
= Right-angle

**-CA3**  
= RG 179 Cable

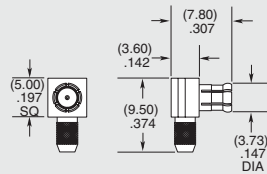

**-P-RA**

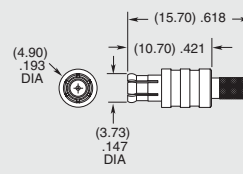

**-P-ST**

Supplied with pins and ferrules. See website for dimensions.

*Due to technical progress, all designs, specifications and components are subject to change without notice.*

[WWW.SAMTEC.COM](http://WWW.SAMTEC.COM)

All parts within this catalog are built to Samtec's specifications. Customer specific requirements must be approved by Samtec and identified in a Samtec customer-specific drawing to apply.



IJ5C-08-0600-S-D-NUS-1

IJ5C-04-0400-S-D-NUS-1

**IJ5C SERIES**

**(4.00 mm) .1575"**

# 50 Ω HIGH ISOLATION RF CABLE ASSEMBLY

**SPECIFICATIONS**

For complete specifications and recommended PCB layouts see [www.samtec.com?IJ5C](http://www.samtec.com?IJ5C)

- Insulator Material:** Black LCP
- Contact Material:** Copper Alloy
- Pin Material:** Copper Alloy
- Dielectric Material:** Black LCP
- Plating:** Au over 50 μ" (1.27 μm) Ni
- Operating Temp Range:** -40 °C to +90 °C
- RoHS Compliant:** Yes

**Cable (-1):**

- Conductor Size:** 26 AWG, (0.48 mm) .019" dia.
- Conductor Material:** Silver Plated Copper
- Insulator Diameter:** (1.27 mm) .050"
- Insulator Material:** Foamed FEP
- Shield Material:** Silver Plated Copper
- Jacket Material:** FEP
- Jacket Diameter:** (1.80 mm) .071"
- Bend Radius:** 3.175 mm
- Impedance:** 50 Ω
- Current Rating:** 2.5 A
- RoHS Compliant:** Yes

**Cable (-2):**

- Conductor Size:** 26 AWG, (0.51 mm) .020" dia.
- Conductor Material:** Silver and Copper Plated Steel Wire
- Insulator Diameter:** (1.52 mm) .060"
- Insulator Material:** PTFE
- Shield Material:** Silver Plated Copper Wire
- Jacket Material:** FEP
- Jacket Diameter:** (2.54 mm) .100"
- Bend Radius:** 12.7 mm
- Impedance:** 50 Ω
- Current Rating:** 5 A DC
- RoHS Compliant:** Yes

**RECOGNITIONS**

For complete scope of recognitions see [www.samtec.com/quality](http://www.samtec.com/quality)



**Note:** This Series is non-standard, non-returnable.

Mates with:  
IP5



- Edge Rate® Contacts
- Positive Latching

Single or Double Ended

High-performance 26 AWG coax cable

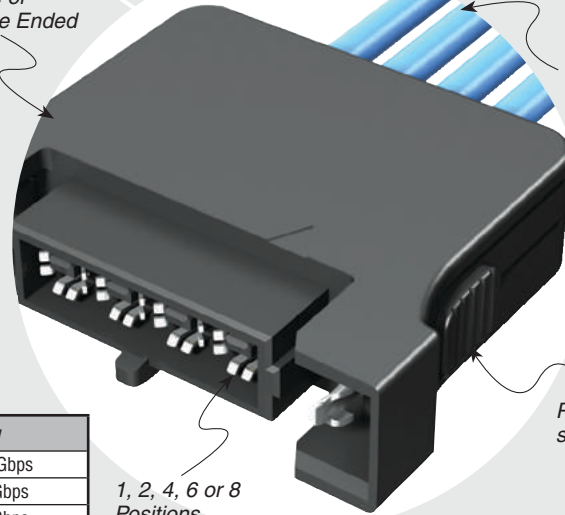

Positive latching system

1, 2, 4, 6 or 8 Positions

1 Meter Cable Assembly	Frequency
Insertion Loss = 3 dB	9.5 GHz / 19.0 Gbps
Return Loss = 15 dB	2.2 GHz / 4.4 Gbps
Isolation = 60 dB	3.1 GHz / 6.2 Gbps

Performance and complete test data available at [www.samtec.com?IJ5C](http://www.samtec.com?IJ5C) or contact [sig@samtec.com](mailto:sig@samtec.com)

IJ5C	NO. OF POSITIONS	ASSEMBLED LENGTH	PLATING OPTION	END OPTION	END 2 OPTION	CABLE TYPE
	-01, -02, -04, -06, -08	- "XXXX" = Assembled Length in millimeters -0100 to -1000 (100 mm) 3.94" minimum	-S = 30 μ" (0.76 μm) Gold on contact	-S = Single Ended  -D = Double Ended	-NUS = Notch up, straight P1 to P1  -NDS = Notch down, straight P1 to PN	-1 = CTB-2650F-01 cable  -2 = RG 316 cable

NO. OF POSITIONS	A
-01	(20.87) .822
-02	(24.87) .979
-04	(32.87) 1.294
-06	(40.87) 1.609
-08	(48.87) 1.924

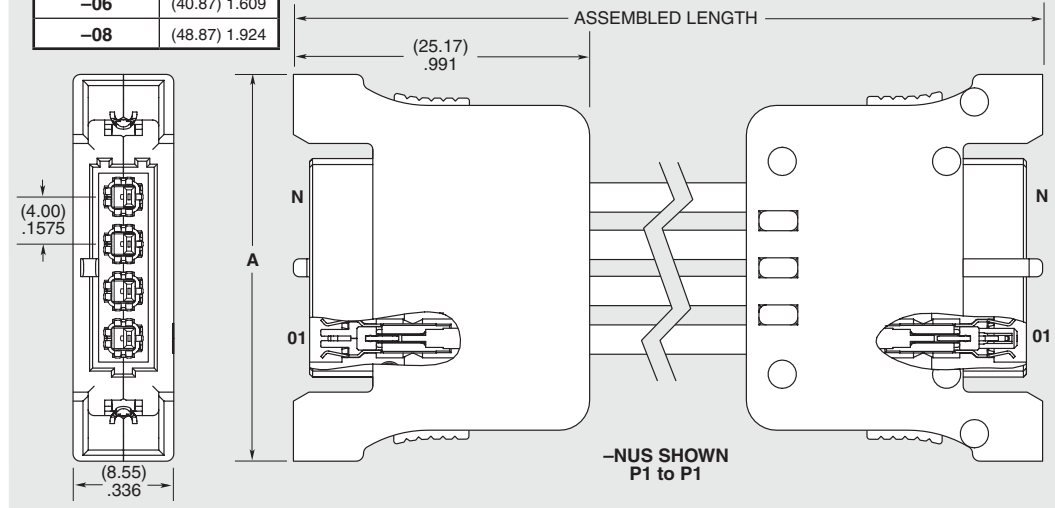

Due to technical progress, all designs, specifications and components are subject to change without notice.



(4.00 mm) .1575"

**IJ5H SERIES**

# 50 Ω HYBRID RF CABLE ASSEMBLY

## SPECIFICATIONS

For complete specifications and recommended PCB layouts see [www.samtec.com?IJ5H](http://www.samtec.com?IJ5H)

- Insulator Material:** Black LCP
- Contact Material:** Copper Alloy
- Pin Material:** Copper Alloy
- Dielectric Material:** Black LCP
- Plating:** Au over 50 μ" (1.27 μm) Ni
- Operating Temp Range:** -40 °C to +90 °C
- RoHS Compliant:** Yes

**Cable (-2):**

- Conductor Size:** 26 AWG, (0.51 mm) .020" dia.
- Conductor Material:** Silver and Copper Plated Steel Wire
- Insulator Diameter:** (1.52 mm) .060"
- Insulator Material:** PTFE
- Shield Material:** Silver Plated Copper Wire
- Jacket Material:** FEP
- Jacket Diameter:** (2.54 mm) .100"
- Bend Radius:** 12.7 mm
- Impedance:** 50 Ω
- Current Rating:** 5A DC
- RoHS Compliant:** Yes

**Mates with:**  
IP5, SMA, MCX, MMCX, SMB5

Low-cost isolated transmission line system

RG 316 Cable

1, 2, 4, 6 or 8 Positions

Positive latching

Choice of traditional RF end options

**EDGE RATE**  
CONTACT

IJ5H	NO. OF POSITIONS	ASSEMBLED LENGTH	END 1 PLATING	CABLE TYPE	END 2 OPTION										
	-01, -02, -04, -06, -08	- "XXXX" = Assembled Length in millimeters -0300 to -1000 (1000 mm) 39.40" maximum	-S = 30 μ" (0.76 μm) Gold on contact	-2 = RG 316 cable	<table border="0"> <tr> <td>All Gold</td> <td>Gold/Nickel combination</td> </tr> <tr> <td>-01SP1 = SMA Straight Plug</td> <td>-02SP2 = MCX Straight Plug</td> </tr> <tr> <td>-02SP1 = MCX Straight Plug</td> <td>-03SP2 = MMCX Straight Plug</td> </tr> <tr> <td>-03SP1 = MMCX Straight Plug</td> <td>-07SP2 = SMB Straight Plug</td> </tr> <tr> <td>-07SP1 = SMB Straight Plug</td> <td></td> </tr> </table>	All Gold	Gold/Nickel combination	-01SP1 = SMA Straight Plug	-02SP2 = MCX Straight Plug	-02SP1 = MCX Straight Plug	-03SP2 = MMCX Straight Plug	-03SP1 = MMCX Straight Plug	-07SP2 = SMB Straight Plug	-07SP1 = SMB Straight Plug	
All Gold	Gold/Nickel combination														
-01SP1 = SMA Straight Plug	-02SP2 = MCX Straight Plug														
-02SP1 = MCX Straight Plug	-03SP2 = MMCX Straight Plug														
-03SP1 = MMCX Straight Plug	-07SP2 = SMB Straight Plug														
-07SP1 = SMB Straight Plug															

NO. OF POSITIONS	A
-01	(20.87) .822
-02	(24.87) .979
-04	(32.87) 1.294
-06	(40.87) 1.609
-08	(48.87) 1.924

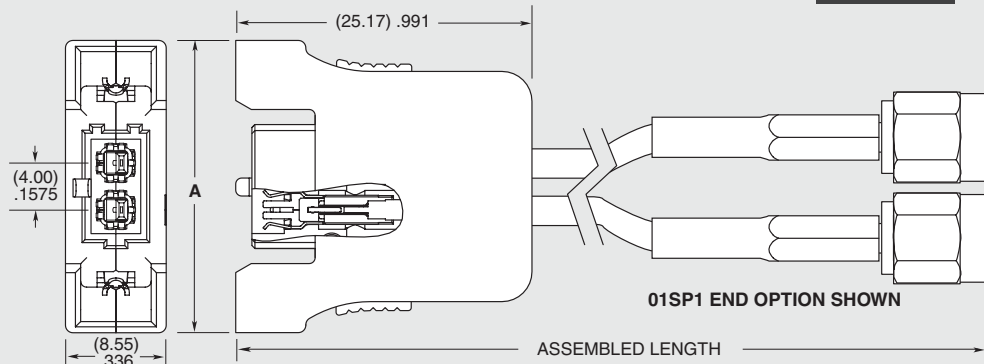

**Note:**  
This Series is non-standard, non-returnable.

Due to technical progress, all designs, specifications and components are subject to change without notice.

[WWW.SAMTEC.COM](http://WWW.SAMTEC.COM)

All parts within this catalog are built to Samtec's specifications. Customer specific requirements must be approved by Samtec and identified in a Samtec customer-specific drawing to apply.

(4.00 mm) .1575"

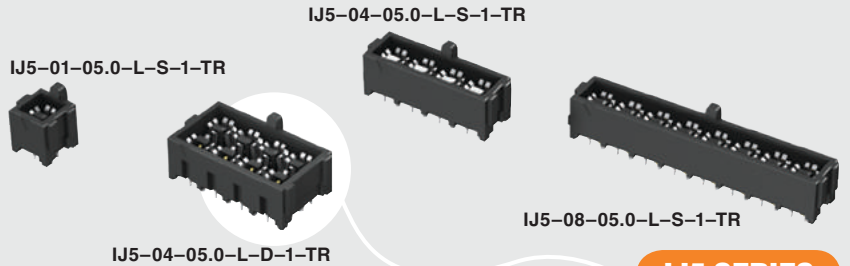

**IJ5 SERIES**

# 50 Ω HIGH ISOLATION RF JACKS

## SPECIFICATIONS

For complete specifications and recommended PCB layouts see [www.samtec.com/IJ5](http://www.samtec.com/IJ5)

**Shell Material:**

Copper Alloy

**Insulator Material:**

Black LCP

**Contact Material:**

Copper Alloy

**Dielectric Material:**

Black LCP

**Plating:**

Au or Sn over

50 μ" (1.27 μm) Ni

**Current Rating (Vertical):**

Signals: 2.36 A per pin

(2 adjacent pins powered)

Grounds: 4.4 A per pin

(2 adjacent pins powered)

**Operating Temp Range:**

-55 °C to +125 °C

**Dielectric**

**Withstanding Voltage:**

600 VAC

**Working Voltage:**

200 VAC

**RoHS Compliant:**

Yes

**Mates with:**

IP5

IP5/IJ5 10 mm Stack Height	Frequency
Insertion Loss = 3 dB	10.5 GHz / 21.0 Gbps
Return Loss = 15 dB	5.5 GHz / 11.0 Gbps
Isolation = 60 dB	8.8 GHz / 17.6 Gbps
Isolation = 70 dB	7.6 GHz / 15.2 Gbps
Isolation = 80 dB	1.3 GHz / 2.6 Gbps

Complete test data available at [www.samtec.com/IJ5](http://www.samtec.com/IJ5) or contact [sig@samtec.com](mailto:sig@samtec.com)

Single or  
Double Row

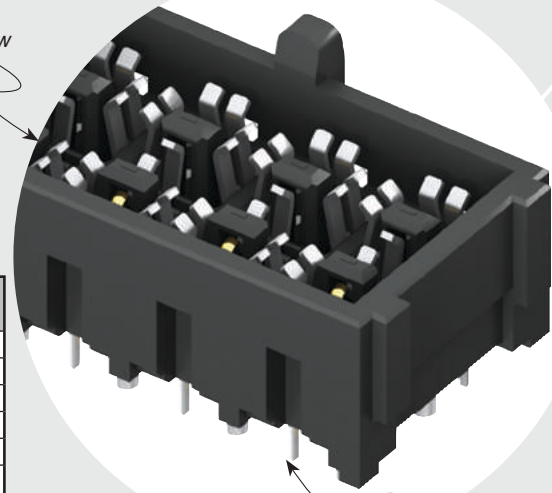

1, 2, 4, 6 or 8  
Positions

## PROCESSING

**Lead-Free Solderable:**  
Yes

## RECOGNITIONS

For complete scope of recognitions see [www.samtec.com/quality](http://www.samtec.com/quality)



FILE NO. E111594

## ALSO AVAILABLE (MOQ Required)

- Other stack heights
  - Other PCB thicknesses
- Contact Samtec.

## OTHER SOLUTIONS

- Cable assembly (see IJ5C Series)

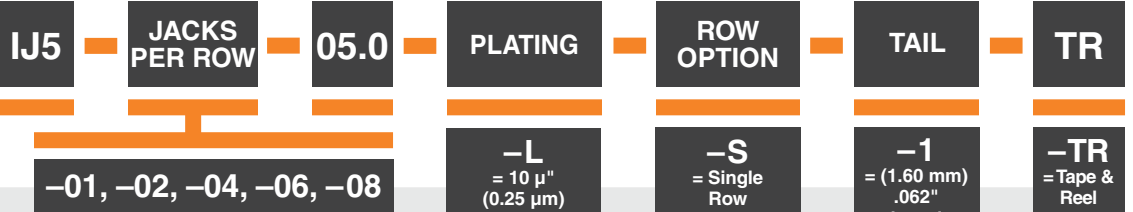

-01, -02, -04, -06, -08

**-L**  
= 10 μ" (0.25 μm)  
Gold on contact area,  
Matte Tin on tail

**-S**  
= Single Row  
**-D**  
= Double Row  
(Not available with -01)

**-1**  
= (1.60 mm) .062" board thickness

**-TR**  
= Tape & Reel

NO. OF JACKS	A
-01	(5.55) .219
-02	(9.55) .376
-04	(17.55) .691
-06	(25.55) 1.006
-08	(33.55) 1.321

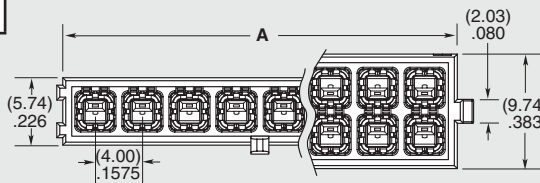

## APPLICATION

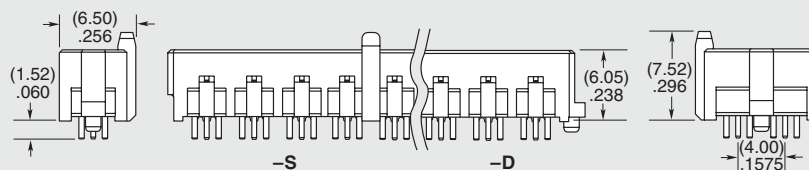
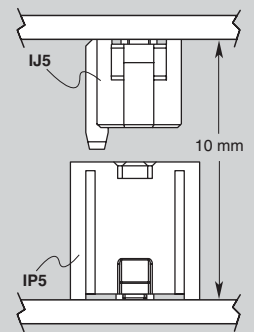

Due to technical progress, all designs, specifications and components are subject to change without notice.

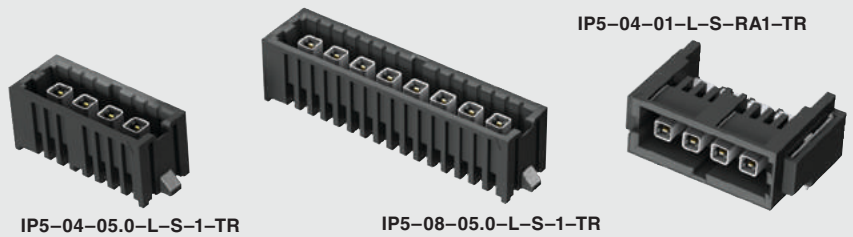

(4.00 mm) .1575"

IP5, IP5-RA SERIES

# 50 Ω HIGH ISOLATION RF PLUGS

## SPECIFICATIONS

For complete specifications and recommended PCB layouts see [www.samtec.com?IP5](http://www.samtec.com?IP5)

**Shell Material:**

Copper Alloy  
**Insulator Material:**  
Black LCP

**Contact Material:**

Copper Alloy  
**Dielectric Material:**  
Black LCP

**Plating:**

Au or Sn over  
50 μ" (1.27 μm) Ni

**Current Rating (Vertical):**

Signals: 2.36 A per pin  
(2 adjacent pins powered)  
Grounds: 4.4 A per pin  
(2 adjacent pins powered)

**Operating Temp Range:**

-55 °C to +125 °C

**Dielectric Withstanding Voltage:**

IP5 = 600 VAC  
IP5-RA = 190 VAC  
**Working Voltage:**  
IP5 = 200 VAC  
IP5-RA = 190 VAC  
**RoHS Compliant:**  
Yes

<b>IP5</b>	<b>PLUGS PER ROW</b>	<b>05.0</b>	<b>PLATING</b>	<b>ROW OPTION</b>	<b>TAIL</b>	<b>OPTION</b>	<b>TR</b>
Mates with: IJ5, IJ5C		<b>-01, -02, -04, -06, -08</b>	<b>-L</b> = 10 μ" (0.25 μm) Gold on contact area, Matte Tin on tail	<b>-S</b> = Single Row <b>-D</b> = Double Row (Not available with -01)	<b>-1</b> = (1.60 mm) .062" board thickness	<b>-L</b> = Cable Latch (Single Row only)	<b>-TR</b> = Tape & Reel

IP5/IJ5 10 mm Stack Height	Frequency
Insertion Loss = 3 dB	10.5 GHz / 21.0 Gbps
Return Loss = 15 dB	5.5 GHz / 11.0 Gbps
Isolation = 60 dB	8.8 GHz / 17.6 Gbps
Isolation = 70 dB	7.6 GHz / 15.2 Gbps
Isolation = 80 dB	1.3 GHz / 2.6 Gbps

Complete test data available at [www.samtec.com?IP5](http://www.samtec.com?IP5) or contact [sig@samtec.com](mailto:sig@samtec.com)

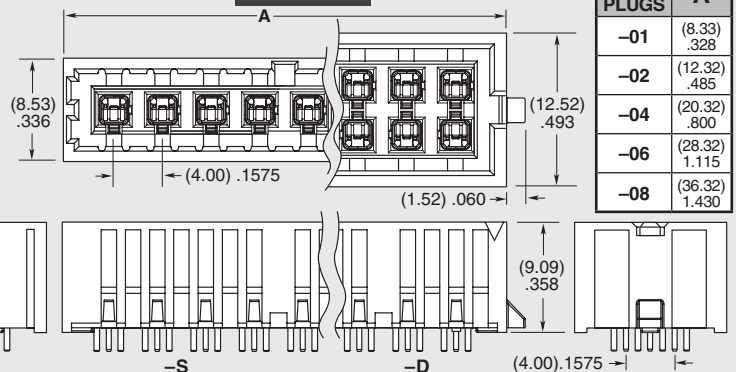

NO. OF PLUGS	A
-01	(8.33) .328
-02	(12.32) .485
-04	(20.32) .800
-06	(28.32) 1.115
-08	(36.32) 1.430

## PROCESSING

**Lead-Free Solderable:**  
Yes

## RECOGNITIONS

For complete scope of recognitions see [www.samtec.com/quality](http://www.samtec.com/quality)



FILE NO. E111594

## ALSO AVAILABLE (MOQ Required)

- Other stack heights
  - Other PCB thicknesses
- Contact Samtec.

<b>IP5</b>	<b>PLUGS PER ROW</b>	<b>01</b>	<b>PLATING</b>	<b>S</b>	<b>TAIL OPTION</b>	<b>OPTION</b>	<b>TR</b>
Mates with: IJ5, IJ5C		<b>-02, -04, -06, -08</b>	<b>-L</b> = 10 μ" (0.25 μm) Gold on contact area, Matte Tin on grounds, tails & weld tabs	<b>-RA1</b> = (1.60 mm) .062" board thickness	(Leave blank for no Cable Latch) <b>-L</b> = Cable Latch	<b>-TR</b> = Tape & Reel	

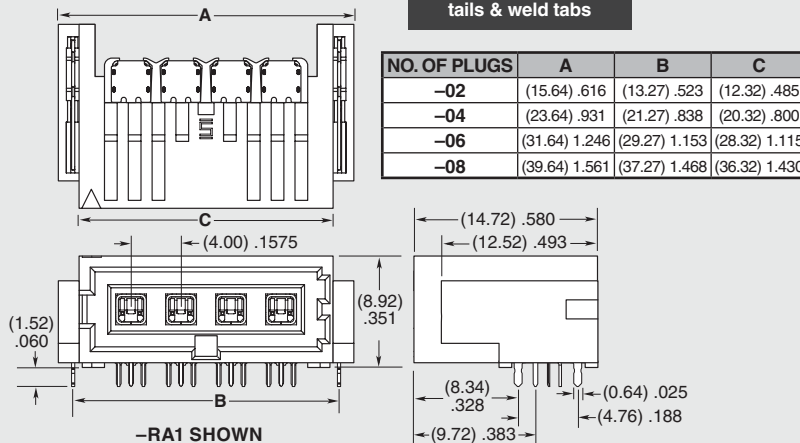

NO. OF PLUGS	A	B	C
-02	(15.64) .616	(13.27) .523	(12.32) .485
-04	(23.64) .931	(21.27) .838	(20.32) .800
-06	(31.64) 1.246	(29.27) 1.153	(28.32) 1.115
-08	(39.64) 1.561	(37.27) 1.468	(36.32) 1.430

## APPLICATION

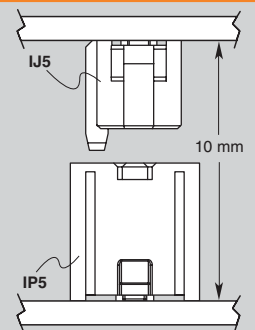

Due to technical progress, all designs, specifications and components are subject to change without notice.

# CUSTOM RF SOLUTIONS

## EXPRESS MODIFICATIONS

- Quick-turn prototype samples
- Short lead times
- Low or no Nonrecurring Engineering Charges (NREs)
- Low or no tooling charges

## RF Board Level Interconnects

- Custom tail lengths
- Through-hole termination to surface mount or mixed technology
- Right-angle height adjustment from PCB
- Alternate plating options

## RF Cable Assemblies

- Performance testing: VNA, TDR
- Custom labels and heat-shrink tubing
- Non-standard connector termination orientation
- Adding or removing bulkhead mounting
- Alternate plating options

## ENGINEERED CUSTOMS

- Full engineering, design and prototype support from Samtec's RF Group
- Design, simulation and processing assistance
- Flexible, quick-turn manufacturing
- Dedicated engineers and technicians for application specific RF products

## RF Board Level Interconnects

- Completely customized to your specifications

## RF Cable Assemblies

- Completely customized to your specifications
- Customized connector terminated to existing cable
- Customized cable terminated to existing connector

## RF GROUP

- Personal support from Samtec's highly qualified, in-house staff of RF engineers
- Express modifications to standard products to complete engineering, design and prototype support
- Design, simulation and processing assistance
- Dedicated engineers and technicians for application specific RF products
- Contact [RFTechnicalGroup@samtec.com](mailto:RFTechnicalGroup@samtec.com)

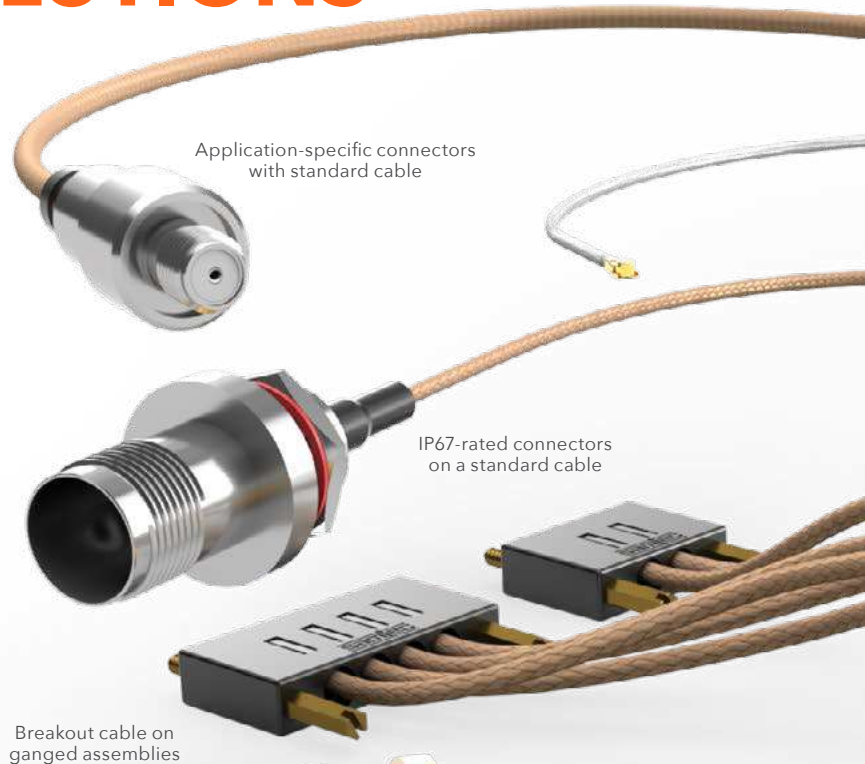

# INDEX

\*New products highlighted in bold.



Substitute impedance-matched connectors/cables

Bulls Eye® with custom end

Drop-in edge mount on any RF connector

Engineered custom cable adaptors

Non-standard connector orientation

Quick-turn through-hole termination change

Series	Description	Page
292	50 Ω Precision 2.92 mm Jacks	42
292-CA	50 Ω Precision 2.92 mm Cable Components	43
BDR	Replacement block for 20 GHz Bulls Eye® (BDRA)	20
BDRA	20 GHz Bulls Eye® Assembly: Double Row	18
BE23S	Replacement cable for 20 GHz Bulls Eye® (BDRA, BQRA)	20
<b>BE40A</b>	<b>50 GHz Bulls Eye® Assembly: Double Row</b>	<b>17</b>
<b>BE40B</b>	<b>Replacement block for 50 GHz Bulls Eye® (BE40A)</b>	<b>20</b>
<b>BE40C</b>	<b>Replacement cable for 50 GHz Bulls Eye® (BE40A)</b>	<b>20</b>
BNC5-CA	50 Ω BNC Cable Components	52
BNC7T	75 Ω, 12G-SDI BNC Jacks	58-59
BNC7T-CA	75 Ω, 12G-SDI BNC Cable Components	58-59
BQR	Replacement block for 20 GHz Bulls Eye® (BQRA)	20
BQRA	20 GHz Bulls Eye® Assembly: Quad Row	19
C28S	100 Ω Shielded Twisted Pair Twinax Cable Assembly	62
CJT	100 Ω Twinax Jack, Through-hole & Bulkhead Through-hole	63
DIN7A	75 Ω, 12G-SDI DIN 1.0/2.3 Jacks	55
DIN7A-CA	75 Ω, 12G-SDI DIN 1.0/2.3 Cable Components	55
GRF1-C	5.00 mm 50 Ω Ganged Micro-Mini RF Plug, Cable	65
GRF1H-C	5.00 mm 50 Ω Ganged Hybrid Micro-Mini RF Cable	66-67
GRF1-J	5.00 mm 50 Ω Ganged Micro-Mini RF Jack, PCB Mount	64
GRF1-P	5.00 mm 50 Ω Ganged Micro-Mini RF Plug, PCB Mount	64
GRF7H-C	5.00 mm 75 Ω Ganged Hybrid Micro-Mini RF Cable	68-69
GRF7-J	5.00 mm 75 Ω Ganged Micro-Mini RF Jack, PCB Mount	70
GRF7-P	5.00 mm 75 Ω Ganged Micro-Mini RF Plug, PCB Mount	70
HDBNC	75 Ω, 12G-SDI High-Density BNC Jacks	56
HDBNC-CA	75 Ω, 12G-SDI High-Density BNC Cable Components	57
IJ5	4.00 mm IsoRate® 50 Ω High Isolation RF Jack Strip	76
IJ5C	4.00 mm IsoRate® 50 Ω High Isolation RF Cable	74
IJ5H	4.00 mm IsoRate® 50 Ω High Isolation Hybrid RF Cable	75
IP5	4.00 mm IsoRate® 50 Ω High Isolation RF Plug Strip	77
MCX	50 Ω MCX Jacks & Plugs	50
MCX7	75 Ω MCX Jacks & Plugs	73
MCX7-CA	75 Ω MCX Cable Components	73
MCX-CA	50 Ω MCX Cable Components	51
MH081	Micro High Frequency RF Cable Assembly, 0.81 mm Diameter	22
MH113	Micro High Frequency RF Cable Assembly, 1.13 mm Diameter	23
MMCX	50 Ω MMCX Jacks & Plugs	49
MMCX7	75 Ω Micro-Mini Jacks & Plugs	72
MMCX-CA	50 Ω MMCX Cable Components	51
MMCX-SW	50 Ω MMCX Switchable Jack	49
NTPE-CA	N Type Jack Cable Components	53
RF047	50 Ω Flexible RF Cable Assembly, (.047" DIA) 28 AWG	71
RF058	50 Ω RF Cable Assembly, RG 58 Cable	31
RF174	50 Ω RF Cable Assembly, RG 174 Cable	24-25
RF178	50 Ω RF Cable Assembly, RG 178 Cable	26-27
RF179	75 Ω RF Cable Assembly, RG 179 Cable	38-39
<b>RF23C</b>	<b>50 Ω Cable Assembly, 23 AWG Solid Dielectric with Copper Shield</b>	<b>34-35</b>
RF23S	50 Ω Cable Assembly, 23 AWG Solid Dielectric	36
RF25S	50 Ω Cable Assembly, 25 AWG Solid Dielectric	36
RF316	50 Ω RF Cable Assembly, RG 316 Cable	28-29
RF402	50 Ω Semi-Flexible RF Cable Assembly, (.141" DIA) 19 AWG	33
RF405	50 Ω Semi-Flexible RF Cable Assembly, (.086" DIA) 24 AWG	32
RFA6T	75 Ω RF Cable Assembly, RG 6 Cable	37
RFB6T	75 Ω RF Cable Assembly, 1694A Cable	37
RFB8T	75 Ω RF Cable Assembly, 1855A Cable	40
RS316	50 Ω RF Cable Assembly, Double-Shielded RG 316 Cable	30
SMA	50 Ω SMA Jacks	44-45
SMA-CA	50 Ω SMA Cable Components	46
SMB5	50 Ω SMB Jacks	48
SMB5-CA	50 Ω SMB Cable Components	48
SMB7H	75 Ω SMB Jacks	60
SMB7H-CA	75 Ω SMB Cable Components	60
SMP	50 Ω SMP Jacks/Plugs & Adaptor	47
SMP-CA	50 Ω SMP Cable Components	47
TNC	50 Ω TNC Jacks	54
TNC-CA	50 Ω TNC Cable Components	54

## GENERAL POLICY

The information contained in this catalog is accurate to the best of our knowledge. Due to technical progress, it is subject to change without notice. Application information is informational in nature and shall not be construed to warrant suitability of products for any particular purpose as performance may vary with the conditions encountered. Any cut strip or custom made items or options are considered "special," non-returnable items. Samtec products are warranted for 30 days and the warranty is limited strictly to replacement of products with defective workmanship.

Federal Supply Code: 55322



**samtec**

**SUDDEN SERVICE®**

#### **SAMTEC USA**

P.O. Box 1147 • New Albany, IN 47151-1147 USA  
+1-800-SAMTEC-9 (+1-800-726-8329) USA & Canada  
Tel: +1-812-944-6733 • Fax: +1-812-948-5047  
Email: info@samtec.com

#### **SAMTEC NORTHERN CALIFORNIA**

2323 Owen St., Ste 120 • Santa Clara, CA 95054  
+1-800-726-8329 (USA & Canada)  
Tel: +1-812-944-6733 • Fax: +1-408-217-5171  
Email: samtecsiliconvalley@samtec.com

#### **SAMTEC SOUTHERN CALIFORNIA**

5410 Trabuco Road • Suite 120 • Irvine, CA 92620  
Tel: +1-800-726-8329  
Email: samtecsoutherncalifornia@samtec.com

#### **SAMTEC SOUTH AMERICA**

Rua Alagoas Nr 1460 • Sala 805 • Bairro Savassi  
Belo Horizonte - Minas Gerais 30130-160 • Brazil  
Tel: +55 31 9 9146 4447  
Email: brazilsales@samtec.com

#### **SAMTEC UNITED KINGDOM**

11 Mollins Court • Westfield, Cumbernauld  
Scotland G68 9HP  
Tel: +44 01236 739292 • Fax: +44 01236 727113  
Email: scotland@samtec.com

#### **SAMTEC GERMANY**

Streiflacher Str. 7 • 82110 Germering • Germany  
+0800 SAMTEC9 (+0800 / 72 68 329) Germany only  
Tel: +49 (0) 89 / 89460-0 • Fax: +49 (0) 89 / 89460-299  
Email: germany@samtec.com

#### **SAMTEC FRANCE**

Val d' Europe Park • 11, rue du Courtaulin - Bâtiment B  
77700 Magny le Hongre • France  
Tel: +33 1 60 95 06 60 • Fax: +33 1 60 95 06 61  
Email: france@samtec.com

#### **SAMTEC ITALY**

Via Colleoni 25 • Centro Direzionale Colleoni  
Palazzo Pegaso Ingresso 3  
20864 Agrate Brianza-Monza Brianza (MB) • Italy  
Tel: +39 039 6890337 • Fax: +39 039 6890315  
Email: italy@samtec.com

#### **SAMTEC NORDIC/BALTIC**

Solkraftsvägen 25 • 13570 Stockholm • Sweden  
Tel: +46 8 4477280 • Fax: +46 8 7420413  
Email: scandinavia@samtec.com

#### **SAMTEC BENELUX**

11 Mollins Court • Westfield, Cumbernauld  
Scotland G68 9HP  
Tel: +44 01236 739292 • Fax: +44 01236 727113  
Email: benelux@samtec.com

#### **SAMTEC ISRAEL**

21 Bar-Kochva St. • Concord Tower  
B'nei Brak, Israel 51260  
Tel: +972 3 7526600 • Fax: +972 3 7526690  
Email: israel@samtec.com

#### **SAMTEC INDIA**

#11, 2nd Floor, Chetana, Dattatreya Road  
Basavanagudi • Bangalore • 560 004 India  
Tel: +91 80 3272 1612 • Fax: +91 80 2662 0967  
Email: india@samtec.com

#### **SAMTEC ANZ**

2A San Antonio Court • Mentone 3194  
Victoria, Australia  
Tel: +613 9580 0683 • Fax: +613 9580 0684  
Email: australia@samtec.com

#### **SAMTEC SINGAPORE**

1 Kallang Sector #05-01/02 • Kollam Ayer Industrial Park  
Singapore 349276  
Tel: +65 6745 5955 • Fax: +65 6841 1502  
Email: singapore@samtec.com

#### **SAMTEC JAPAN**

Nisso No. 16 Bldg. • 3-8-8, Shinyokohama, Kohoku-ku  
Yokohama-shi, Kanagawa 222-0033 Japan  
Tel: +81 45 475 1385 • Fax: +81 45 475 1340  
Email: japan@samtec.com

#### **SAMTEC SHANGHAI**

Unit 601, Qilai Building • No 889 Yishan Road  
Shanghai, China 200233  
Tel: +86 21 6083 3766 • Fax: +86 21 5423 4575  
Email: china@samtec.com

#### **SAMTEC SHENZHEN**

Rm 906B 9/F New World Center Tower  
Yi Tian Road, Fu Tian District • Shenzhen, China 518026  
Tel: +86 755 83776780 • Fax: +86 755 83776767  
Email: hongkong@samtec.com

#### **SAMTEC TAIWAN**

Room D, Floor B1, No. 205, Sec. 3 • Beixin Rd.  
Xindian District • New Taipei City 23143 • Taiwan  
Tel: +886 2 7727 4060 • Fax: +886 2 7727 4179  
Email: taiwan@samtec.com

#### **SAMTEC HONG KONG**

Room 18, 13/F, Shatin Galleria • 18-24 Shan Mei Street  
Fo Tan, Shatin, Hong Kong  
Tel: +852 26904858 • Fax: +852 26904842  
Email: hongkong@samtec.com

#### **SAMTEC KOREA**

RM#705, 109 Gwanggyo-ro  
Yeongtong-gu, Suwon-si, Gyeonggi Do  
16229 South Korea  
Tel: +82 31 717 5685 • Fax: +82 70 7500 0246  
Email: korea@samtec.com

#### **SAMTEC ONLINE**

www.samtec.com