



RF & MICROWAVE  
SWITCHES

# COAXIAL SWITCHES

---

*Full Line Catalog*

## **SIMPLIFICATION** *is our INNOVATION*

*Radiall is a community of dedicated individuals with a shared purpose: simplify life for all those who innovate. Our manufacturing expertise allows us to deliver lighter and smaller products that simplify implementation and drive performance. We recognize that simplification starts with us, but proves its true benefits when it reaches you.*



# TABLE OF CONTENTS

Technical Information	<b>1</b>
SPDT	<b>2</b>
DP3T & SPDT Terminated	<b>3</b>
DPDT	<b>4</b>
SPnT	<b>5</b>
Low PIM	<b>6</b>
Space	<b>7</b>
Other	<b>8</b>
Navigator	<b>9</b>



AEROSPACE



DEFENSE



TELECOM



INDUSTRIAL & RAIL



SPACE



TEST & MEASUREMENT



MEDICAL

# OUR COMPANY

*Since 1952, we have been enabling the future through collaboration with our customers. The results are a range of innovative and award-winning products that customers trust for unrivaled repeatability and performance.*

We are a global company with facilities around the world that specializes in manufacturing the highest-quality interconnect components to support the most demanding applications. At Radiall, you can rely on us to be the industry's global market leader.

## INDUSTRIES WE SERVE

For over 60 years, we have fostered relationships grounded in trust by sharing our extensive market knowledge, technological expertise and experience in each and every interaction. Through an understanding of our customers' unique challenges, we are able to design simple solutions specific to their application and requirements.

Visit [www.radiall.com](http://www.radiall.com) for more information.

## OUR VALUES

Guiding Our Actions  
Every Day



### GROW TOGETHER

*With Our Teams and  
the World Around Us*



### BE GENUINE

*To Foster Mutual  
Trust and Grow*



### MAKE IT SIMPLE

*To Accelerate Innovation*



### DARE TO BE AUDACIOUS

*To Make a Difference*



## AWARDS & CERTIFICATIONS

Being recognized for our product performance, innovation and timely fulfillment is a testament to our employees' commitment to our customers. We are a world market leader in reliable, repeatable performance and take great pride in providing award-winning innovation and vendor support.

Our leadership is focused on long-term success and developing key technologies that simplify our customers' lives.

We're committed to our people, the environment and to the highest quality standards including ISO 9001, ISO 14001 and AS9100 certifications. We are compliant with the EU Restriction of Hazardous Substances (RoHS) as well as the Registration, Evaluation, Authorization and Restrictions of Chemicals (REACH) systems.

*Visit our website to view RoHS and REACH compliance information for specific Radiall part numbers.*



Obregón



Connecticut

## IN-HOUSE TECHNOLOGIES

- High-Precision Machining
- Stamping
- Plating
- Molding
- Polishing
- Laser, Ultrasonic, Vapor, Soldering
- Etching on Si
- Thick Film on AlN
- Testing and Simulation



Château-Renault



Shanghai



L'Isle-d'Abeau



Centr'Alp

# GLOBAL PRESENCE

*Recognizing that relationships are rooted in trust, we strive to earn our customers' confidence by demonstrating our market knowledge, technological expertise and experience in each and every interaction.*

● SALES OFFICES   ● INDUSTRIAL PLANTS

# COMPREHENSIVE PORTFOLIO

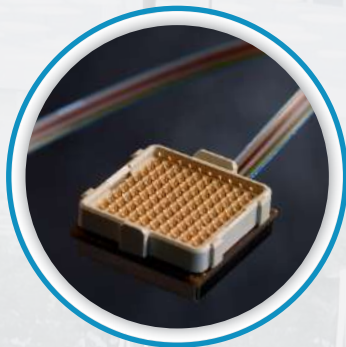

### **Active Optics**

Our high-performance, optical interconnection brand, D-Lightsys®, provides optical transceiver and electronic solutions suitable for harsh environments.



### **Antennas**

With a military and industrial focus, we have solutions for radio tactical communications, vehicles, positioning, LMR/PMR and telemetry applications.



### **Microwave Components**

Our range covers a wide frequency spectrum from DC to 50 GHz, and includes terminations, attenuators, couplers, power dividers, filters and other specialized components.



### **Optical Connectors**

Designed for demanding applications where reliability and high performance are required, our cost-effective optical connectors serve telecom, industrial, aerospace and defense markets.



### **Outdoor Connectors**

Designed for outdoor conditions, our range includes high-power RF coaxial connectors, linking antennas and radio units, as well as innovative multi-signal I/O solutions for optical, Ethernet, power or coaxial links between radio and network.



### **RF & Microwave Switches**

The patented design of our unique, modular actuator and transmission links guarantees operation up to 10 million cycles with superior repeatability.



At Radiall, we provide a comprehensive portfolio of products that meet the application requirements of the key industries we serve. By listening to our customers, we continuously develop new solutions and update our extensive range of products.

With over sixty years of experience and an understanding of the ever-changing business and our customers' technical requirements, we deliver the optimal and most cost-effective, end-to-end interconnect solutions available today.

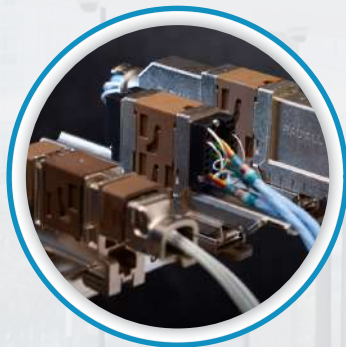

#### ***Multipin Aerospace Connectors***

For more than 40 years, commercial airframes have trusted our range of rack and panel connectors and modular solutions. Our new miniature connector series combines high performance and reduced weight to meet civil and military aerospace industry demands.



#### ***Multipin Industrial Connectors***

Our Van-System brand designs and produces a range of robust circular electrical connectors suitable for harsh environments, such as railways, machine tools, and plant engineering equipment.



#### ***Optical Cable Assemblies***

Our extensive product range and worldwide presence supports customers with standard configurations as well as optimized solutions based on customer requirements.



#### ***RF Cable Assemblies***

Low-loss and high-frequency characterize our extensive range of cable assemblies, including flexible, semi-rigid and hand-formable solutions with a broad combination of cables and connectors.



#### ***RF Coaxial Connectors***

We offer the widest range of RF coaxial connectors in the industry; 55 product series are available, including AEP and Mil QPL connectors.



#### ***Space Qualified Components***

Known for high quality as well as reliability and performance, our product offering includes a wide range of coaxial connectors, cable assemblies, microwave components and switches with a frequency range up to K<sub>a</sub> band.

NOTES

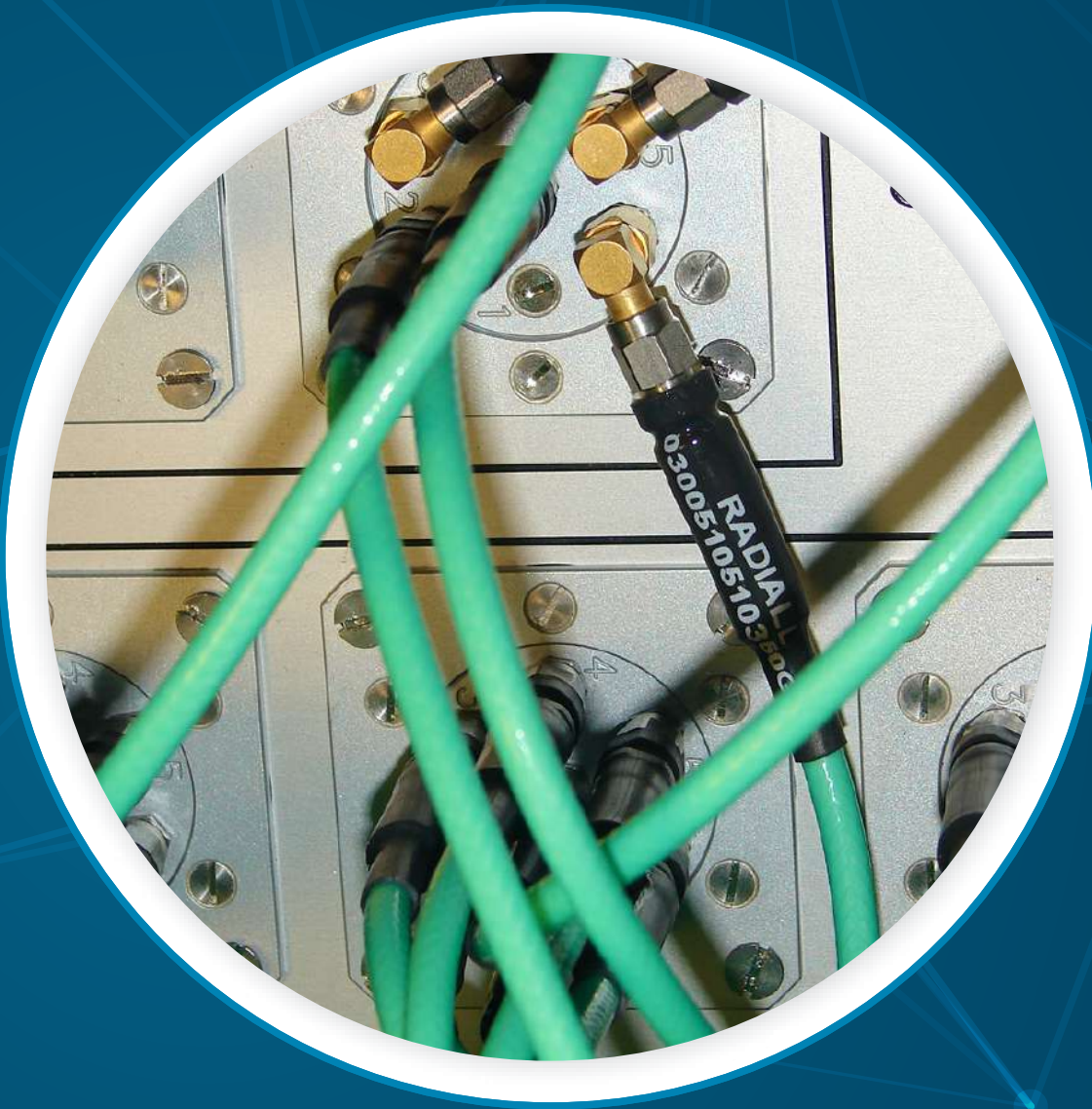

## TECHNICAL INFORMATION

---



*Section 1 Table of Contents*

**INTRODUCTION**

Coaxial Switches Activity Information..... 1-2 to 1-6

Manufacturing and Quality Assurance Flow ..... 1-7

RAMSES Concept..... 1-8 to 1-9

RF Arrangement..... 1-10

Glossary (including RF Power Rating Chart page 1-13) ..... 1-11 to 1-12

RF Repeatability and Life Test Parameters..... 1-15

Conversions ..... 1-16 to 1-20

User Handbook ..... 1-21

Applications ..... 1-22

*Introduction*

## COAXIAL SWITCHES ACTIVITY INFORMATION EXPERIENCE

With over 60 years of experience and continuous efforts in R&D, Radiall has become Europe's number one source for coaxial connectors. Radiall's position as a market leader has enabled the company to excel in the passive microwave component field for more than 50 years. Radiall's expertise in design, development and manufacturing of passive microwave components is widely acknowledged in today's industry.

### A WIDE RANGE OF SOLUTIONS

Specialized in passive microwave components, Radiall's design team and engineering staff manufactures a wide range of standard coaxial devices including: terminations, attenuators, couplers, coaxial detectors and coaxial switches covering a frequency range from DC to 50 GHz.

### RESEARCH & DEVELOPMENT

Due to the increased complexity of microwave systems, more high performance components are required.

To meet these requirements, Radiall's R&D department is constantly working on development of new products and improvement on existing products.

Equipped with microwave and mechanical CAD and the latest generation of microwave test equipment up to 60 GHz, Radiall uses state-of-the-art technology to optimize products and quickly respond to specific customer requests.

### CAPACITIES & FACILITIES

Radiall's global presence and worldwide facilities offer expertise in the following: marketing, research and development, industrialization, manufacturing and quality control. This strong heritage enables Radiall to produce a range of high performance and low cost devices for industrial applications, and high reliability components for severe requirements in military and space markets.



Head office - Aubervilliers France

Introduction

**COAXIAL SWITCHES ACTIVITY INFORMATION PRODUCTION**

Electrical performance of microwave products is determined by machining quality of individual piece parts and associated plating.

Equipped with computer-controlled machinery, and an in-house plating department, Radiall is able to manufacture high quality piece parts that are compatible with existing components.

Due to the thick and thin film etching equipment, Radiall's production department guarantees the quality of the resistive cells used in most terminated switching products. A prototype workshop allows Radiall to quickly respond to special customer request.

All the phases of manufacturing and test are strictly inspected by our quality department, so as to warrant the constancy of our products and to achieve general and specific requirements.

Radiall's quality department inspects products through all phases of manufacturing and testing, to ensure consistency to all products for customer satisfaction.

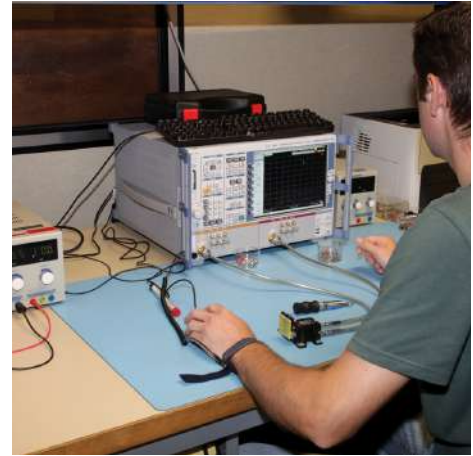

**QUALITY, RELIABILITY & PATENTS**

Radiall's main focus for passive microwave components are quality and reliability. EN 9100:2009 label is the best evidence of quality assurance interfaces at every stage of a product from designing to manufacturing.

All new products are subject to a rigid qualification program before massive production begins. Additionally, product quality is reviewed and tested periodically.

**NATO CODE**

Radiall is a qualified microwave components manufacturer under military label (manufacturer code F0503 and F6507), and offers quality assurance developed in accordance with N.A.T.O. standards.



Introduction

**COAXIAL SWITCHES ACTIVITY INFORMATION**  
**A TESTING LABORATORY**

As an illustration of Radiall’s commitment to quality and reliability, Radiall has an in-house test laboratory qualified by CECC which permits Radiall to complete the majority of tests required by customers.

**PARTIAL LIST OF TEST MEANS**

*Electrical*



Breakdown voltage	12 K Volts
Insulation resistance	40.10 <sup>3</sup> M Ohms
Contact resistance	1 μ Ohms

*Environmental*



Vibrations: Sine random	0 - 120 g; 5 to 4,000 Hz
Shocks	30 to 1,000 g
Shakes	25 to 40 g 6 ms
Thermal vacuum	10 <sup>-5</sup> TORR; -45 to +100 °C
Thermal shock	-70 °C +200 °C / transfert 20 s
Storage temperature	-70 °C to +200 °C
Humidity	20 to 98% HR
Salt Spray	-35 °C to +55 °C
Hermeticity	Helium 10 <sup>-5</sup> to 10 <sup>-8</sup> atm cm <sup>3</sup> /s

*Microwave*

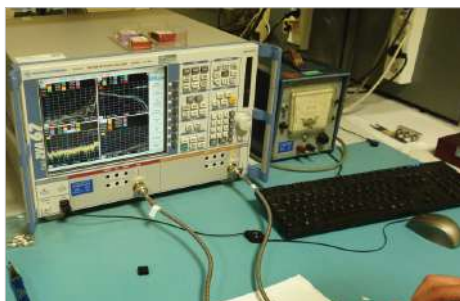

V.S.W.R. insertion loss Isolation	Vector Network Analyzer From 0.01 up to 70 GHz
RF Leakage / EMC	Reverberation chamber method 0.5 to 40 GHz / Noise 100 dB
Power Handling	400 W CW 0.8 up to 2 GHz 200 W CW 2 up to 4 GHz 20 W CW 8 up to 18 GHz 2,000 Wpp 1 up to 2.5 GHz 2,000 Wpp 2.5 up to 8 GHz



Introduction

**COAXIAL SWITCHES ACTIVITY INFORMATION CAPABILITIES**

Radiall offers a wide variety of coaxial switches to answer customer needs. This catalog is intended to be used as a guide in selecting the right type of switch for a given application. It is important to note that Radiall is not limited to catalog products and has the flexibility to design a specific product on a tight schedule at a reasonable cost. Radiall is always available to discuss specific customer requests.



**RELIABILITY**

Radiall's coaxial switches offer exceptional reliability and performance. A unique patented design of the actuator and transmission link enables Radiall to guarantee operation up to 10 million cycles for Terminated SPnT and other series as well — with excellent repeatability.



**LIST OF APPLICABLE DOCUMENTS**

List of related documents covering the general mechanical and environmental tests applicable to the devices described in this catalog.

AIR 7304	NFC 93563	MIL C 39012
DIN 47295	NFC 93564	MIL E 5400
NFC 93561	NFC 96317	MIL STD 202
NFC 93562	MIL DTL 3928	154 IEC

Introduction

## COAXIAL SWITCHES ACTIVITY INFORMATION

### GENERAL SPECIFICATIONS DESIGNED TO MEET MIL DTL 3928 & MIL STD 202

#### ENVIRONMENTAL CHARACTERISTICS

<b>VIBRATIONS METHOD 204</b>	10 - 2,000 Hz 10 g	Operating
<b>SHOCKS METHOD 213</b>	50 g, 1/2 sine	Non-operating

#### MECHANICAL CHARACTERISTICS, MATERIAL & FINISHED

<b>RF BODY</b>	Aluminium, Gold-plated Aluminium, Nickel-plated Aluminium with Cr3 passivation
<b>CONTACTS</b>	Beryllium Copper, Gold-plated
<b>INSULATOR</b>	PTFE, ULTEM 1,000
<b>CONNECTORS</b>	Stainless steel, passivated brass, Nickel-plated
<b>CONSTRUCTION</b>	Splash proof
<b>COVER</b>	Aluminium, blue anodized

*These requirements are guaranteed according to MIL standard — see applicable product section to get more accurate and detailed information.*

*All materials and finishes are in accordance with applicable MIL and NF specifications. All connectors are in accordance with applicable MIL, DIN, NF and CEI specifications. All dimensions in this catalog are given in millimeters. The non specified dimensions are given within +/- 0.5 mm.*

#### MANUFACTURING & QUALITY ASSURANCE

Radiall's RF switches product line is made of approximately 20 series of switches, with each series divided into a large number of configurations. Part numbers consist of 9 digits, each digit designating a portion of the part's actual identity (such as series, frequency, actuator voltage, etc.).

For each digit, 2 to 10 options are available. A complete part number represents a unique configuration.

Overall, there are more than 80,000 different configurations available with very few subassemblies due to the modularity of the RAMSES switching line (less than 300 different subassemblies).

A Push-Pull manufacturing process has been implemented to reduce both lead time and inventory. Based upon marketing forecast and monthly updates, various subassemblies are manufactured.

When an order is received, an automated MRP system selects the appropriate subassemblies from stock to manufacture the requested products within a short time frame (a few days to a few weeks) depending on the complexity of the product.



*Radiall has adopted the process management philosophy of "Lean Manufacturing." This process enables the best possible price and lead times on coaxial products by eliminating unnecessary stages of the administrative processes. The lean manufacturing concept was first applied to the RAMSES SPDT and SP6T non-terminated coaxial products and is now being expended over all coaxial switches.*

#### PACKAGING

All our coaxial switches are packed in a Korrvu packaging. For electromagnetic sensitive switches we also use ESD packet.

#### TRACEABILITY

All our coaxial switches are equipped with a barcode for better traceability. Titanium and Platinum series switches are also equipped with a serial number.



Introduction

**MANUFACTURING & QUALITY ASSURANCE FLOW**

**QUALITY**

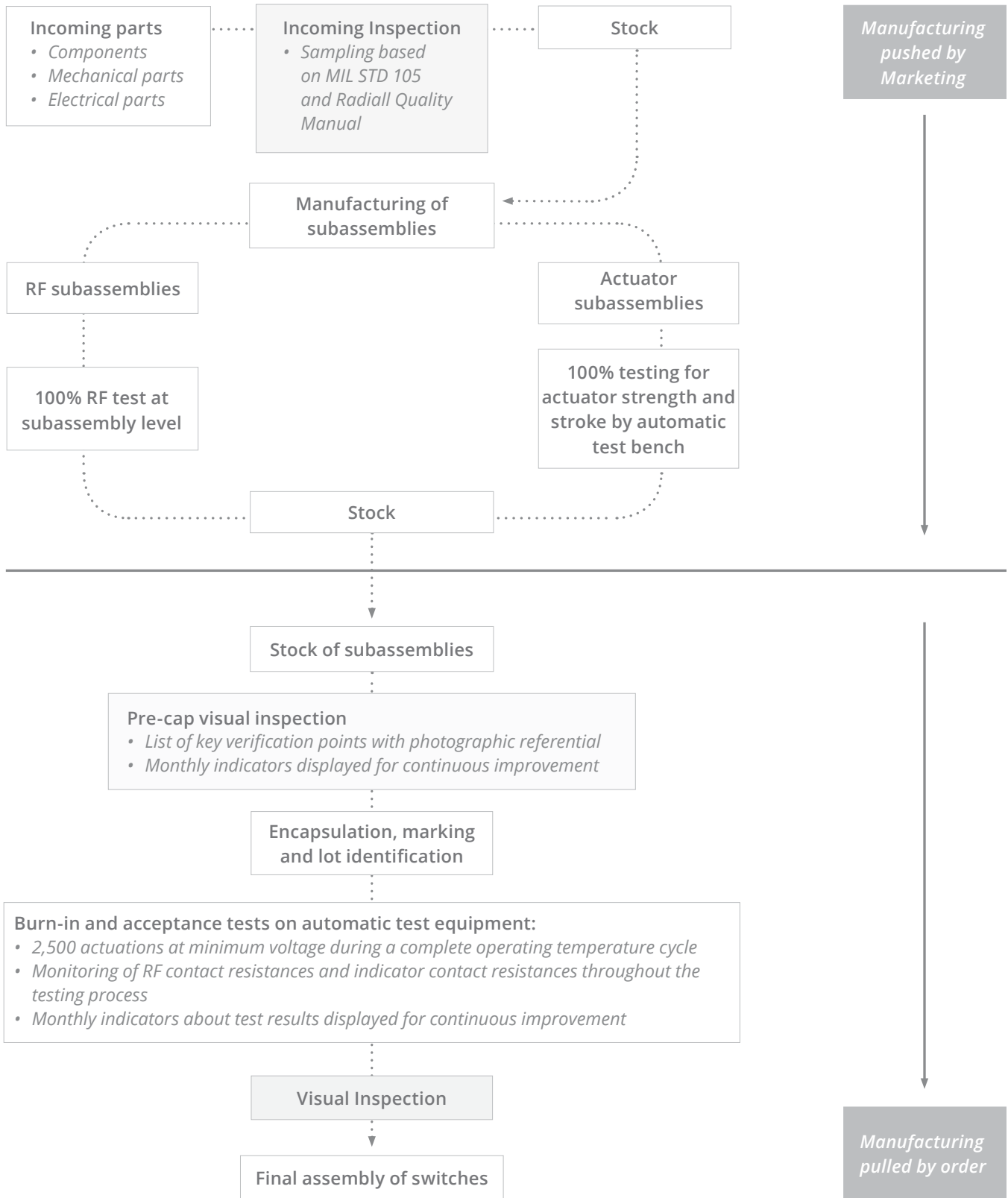

## Introduction

**RAMSES CONCEPT**

An innovative system has been designed for constructing electromechanical coaxial RF switches with increased long-term reliability. Radiall's Modular System for Electromechanical Switches (RAMSES) is a patented concept that enables microwave coaxial switches to be produced with a typical operating life of 10 million cycles while suffering no decrease in contact resistance reliability over time. In addition, the unique internal construction makes the switches cost-competitive with traditional switches.

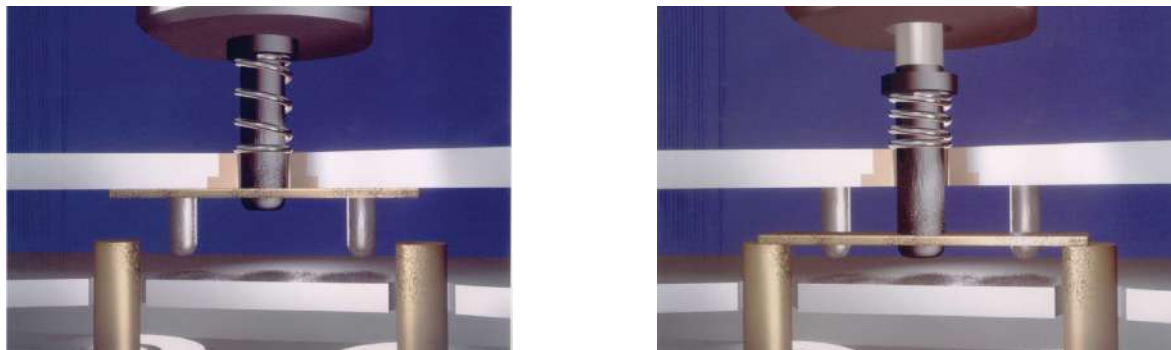
**FIG. 1: CONVENTIONAL SWITCH CONTACTS AFTER ONE MILLION CYCLES**

(a) RF line open

(b) RF line closed

**FRICION EFFECTS**

The unique design of RAMSES is based on the reduction of friction, which minimizes particle deposits that can interfere with the transmission of lower frequency signals (up to 3 GHz).

This particle elimination effect is particularly important for telecommunication applications that are currently in the 900 MHz and 2 GHz range. In addition, the design involves fewer components compared to other microwave switches, making it quick and easy to assemble.

These savings directly relate to lower cost for improved performance. Many of the existing coaxial electromechanical switches also are able to function mechanically for 10 million operations.

However, the reliability and quality of the electrical contact can decrease over the life cycle.

In general, these traditional switches operate by moving a rectangular switching blade section inside a rectangular cavity. The blades are linked with pushers constructed of dielectric material that travel inside an access hole between the RF cavity and switch actuator. The pushers are directed by dielectric material guides. These dielectric parts rub on the blades and inside the access hole and generate isolating particles in the RF cavity that pollute the electrical contacts and ultimately cause running defects.

Figure 1 shows the build-up of minute dielectric particles on a set of conventional switch contacts after one million cycles. These defects are not particularly noticeable at very high frequencies since the contact is established by a capacitive effect. However, the insertion loss of the contacts increases considerably at lower frequencies (3 GHz below).

Introduction

**RAMSES CONCEPT**

**A NEW ACTUATOR CONFIGURATION**

To eliminate this problem of increased insertion loss in the contacts, RAMSES devices incorporate a patented system. This system, compresses two parallel blades suspended from a bearer, which enables the guiding and positioning of the commutation blades to be accomplished entirely outside the RF cavity. These blades impose a rectilinear motion on the switching pusher, suppressing both friction and the production of particles inside the RF cavity. The unique system is extremely small and can be used in all of RAMSES series switches.

**FIG. 2: CUTAWAY VIEW**



**FIG. 3: A RAMSES SET OF CONTACTS**



Figure 2 shows a cutaway view of a RAMSES coaxial switch displaying the actuator mechanism. A second improvement involves a new rectilinear actuator design using high energy magnets and a switching performance in relation to its size.

The system is used in the production of both failsafe and latching actuators, depending on how it is applied in the switch. These actuators are either 500 g locking forces or 300 to 800 g current forces for a power consumption of 100 mA at 28 V.

The new actuator has the added advantage of very low magnetic leakage, allowing actuators to be used in close proximity to one another without performance degradation. The use of a dry, solid lubricant and the control of friction areas provide an actuator life expectancy of over 50 million operations without defect when temperature range exceeds -40 ° to +85 °C.

**SWITCH PERFORMANCE**

RAMSES series switches have successfully survived tests of 10 million switching temperature cycles from -55 ° to + 85 °C while demonstrating good contact resistance stability. Visual inspection of these switches after testing has indicated that the RF lines were free of much of the contamination found during similar tests on traditional switches. A comparison of the actual measured contact resistance obtained from monitoring both conventional and RAMSES switches using several parts that have already been actuated one million cycles is shown in figure 4. Although the conventional switch may not be considered failure, its contact resistance has become unstable, thus degrading its reliability.

**FIG. 4: A COMPARISON OF (A) CONVENTIONAL & (B) RAMSES SWITCH DESIGN CONTACT RESISTANCE DURING ONE MILLION CYCLES**

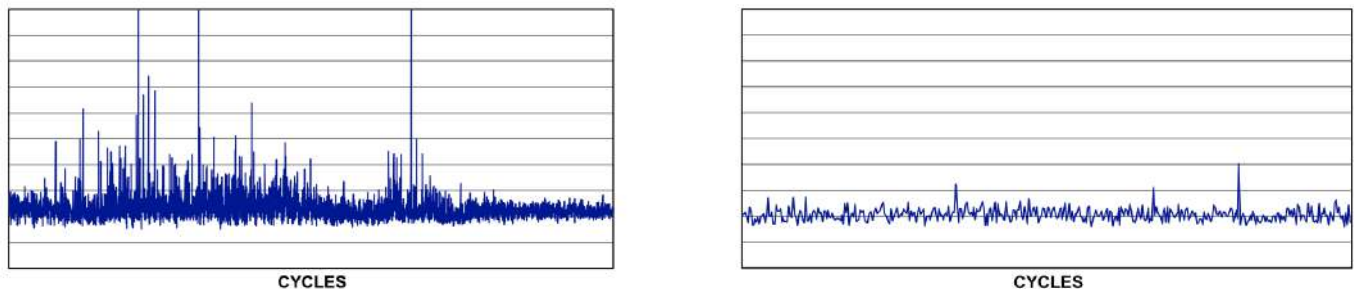

Introduction

RF ARRANGEMENT

COAXIAL SPDT SWITCH

(Single Pole Double Throw)

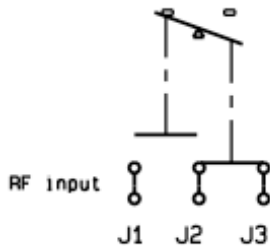

- A switch with one input port and two selectable output ports.

COAXIAL SPDT TERMINATED SWITCH

(Single Pole Double Throw Terminated)

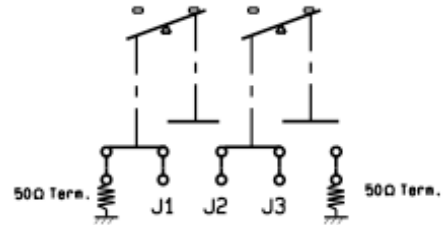

- Same as SPDT, but the unused output port is automatically terminated by a 50 Ohm resistive load.

COAXIAL DP3T SWITCH

(Double Pole Three Throw)

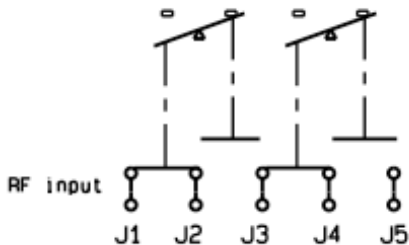

- A switch with two input ports and three output ports. Each input (J2 - J4) can be switched between two adjacent outputs with one output being common to both inputs.

COAXIAL DPDT SWITCH

(Double Pole Double Throw)

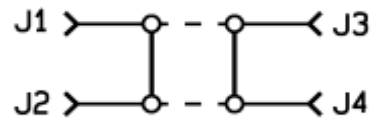

- A four port switch with two independent paths that operate simultaneously in one of two selected positions. In a DPDT/Transfer switch, the two transmission paths are provided as shown above.

COAXIAL MULTIPOSITION SWITCH

(Single Pole n Throw - n<13)

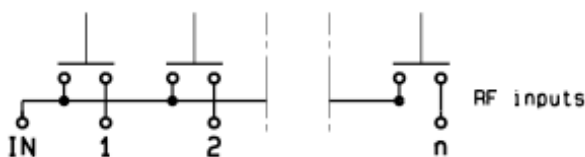

- A switch with one input port and more than two output ports. The multiposition switch allows direct access to any individual output port by energizing the respective actuator. Radiall SPnT switches provide up to 12 output ports.

COAXIAL MULTIPOSITION TERMINATED SWITCH

(Single Pole n Throw Terminated - n<13)

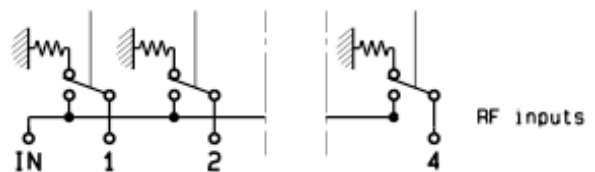

- Same as SPnT, but each unused output port is automatically terminated in an internal 50 Ohm resistive load.

Introduction

**GLOSSARY**

**Actuator Voltage:** All RAMSES series relays are either 12 or 28 Vdc nominal voltage over the entire temperature range. The switches can be operated with a voltage between -15 % and +10 % of the nominal value. Other voltage as 5, 15 or 24 Volts can be supplied at the customer’s request.

**Automatic “Reset”:** All Latching version multiposition switches (or SPnT) cause the following scenario:

When a RF path is closed, it remains in the closed position after the voltage is cut-off (latching function). To switch to another path, the first path must be opened via a “RESET” driver, followed by the closing of the second RF path. Without the “RESET” driver, both paths would remain in the ON position at the same time.

To simplify the use of latching products, an “automatic RESET” is recommended. The auto reset feature is accomplished by an electronic circuit which brings about the automatic opening of a previously closed path during changes of position of the switches.

*This option produces a higher current consumption during a few milliseconds (see voltage and current values listed on the product’s individual technical data sheet).*

**BCD (BINARY CODE DECIMAL) DRIVER INTERFACE**

BCD LOGIC CODING				RF AND MICROWAVE WAYS POSITION
E4	E3	E2	E1	
0	0	0	0	Latching models: all ways in "OFF" position
0	0	0	0	Normally Open models: memory of last position
0	0	0	1	Way IN - 1 in "ON" position
0	0	1	0	Way IN - 2 in "ON" position
0	0	1	1	Way IN - 3 in "ON" position
0	1	0	0	Way IN - 4 in "ON" position
0	1	0	1	Way IN - 5 in "ON" position
0	1	1	0	Way IN - 6 in "ON" position
0	1	1	1	Way IN - 7 in "ON" position
1	0	0	0	Way IN - 8 in "ON" position
1	0	0	1	Way IN - 9 in "ON" position
1	0	1	0	Way IN - 10 in "ON" position
1	0	1	1	Way IN - 11 in "ON" position
1	1	0	0	Way IN - 12 in "ON" position
1	1	1	1	Normally Open models: all ways are in "OFF" position

*E1, E2, E3, E4 are BCD driver pins of the product. E4 applies only with 8 positions or more. E3 applies only 4 positions or more.*

**Break-Before-Make:** Radiall coaxial relays are considered “break-before-make”. In a break-before-make product the contact of the first path leaves its state before the final contact has been established.

**Failsafe:** A switch with an actuator that contains a return mechanism, either mechanical or magnetic, that provides RF connection to one selected position when no voltage is applied to the power terminals. This type of switch requires continuous voltage to maintain RF connection to any other position.

**Frequency Range:** The frequency range for each device indicates the maximum frequency Radiall will guarantee for the products performance.

**Indicator Contacts:** Electrical contacts of an “open circuit, short-circuit” type, mechanically linked to the actuator and synchronized with switched RF paths, ensure the recopy of positions of RF transmission paths. When a microwave path is switched, the corresponding indicator contact is closed. It is generally used with pilot lamps to indicate position of RF contacts (characteristics are given for a resistive load).

## Introduction

## GLOSSARY (CONTINUED)

**Intermodulation (PIM):** or intermod for short, is a form of signal distortion that occurs whenever signals of two or more frequencies are produced in a passive device which contains nonlinear response. This interference includes low contact pressure, dirty interconnects, magnetic materials or other anodic effect. The typical value for Radiall switches is around 120 dBc, except for SMT relays which is 110 dBc (with 2 carriers at +43 dBm), however products can be designed for higher performance upon request.

**Isolation:** The RF leakage from a connected path to any connector outside that path. Isolation is measured in decibels below the input power.

**Latching:** A switch with an actuator that contains a mechanism, either mechanical or magnetic, that will maintain a chosen RF contact path (whether voltage is maintained or not) after switching is accomplished. A pulse length of a duration equal to the maximum switching time is enough to change the switch position.

**Life:** Number of toggles a product is able to carry out. Relays and switches of RAMSES, PLATINUM and TITANIUM ranges have a life cycle of 2 to 10 million cycles.

**Normally Open:** A mode of operation in which all output ports of the switch are disconnected from the input port until a voltage is applied to a selected position.

SWITCHES FAMILY	TYPE OF		PIN NUMBER	COMMENTS
	SERIES	CONNECTOR		
RAMSES SPDT	SPDT = R570	D-Sub (male)	9 pins	Available only on products described on page 2-16
PLATINUM SPDT	SPDT = R595	D-Sub (male)	9 pins	Non-terminated models
RAMSES DPDT	DPDT = R577	D-Sub (male)	9 pins	-
TITANIUM DPDT	DPDT = R513	HE10 ribbon receptacle (male)	10 pins	Delivered with ribbon cable 750 mm (30 inches) + HE10 connector (female)
PLATINUM DPDT	DPDT = R593			
RAMSES DP3T <sup>(1)</sup>	DP3T = R585	N/A		Only solder pins
PLATINUM DP3T <sup>(1)</sup>	DP3T = R595	D-Sub (male)	9 pins	-
RAMSES & Subminiature SPnT	SPnT = R573/R574 3 to 10 positions and 12 positions	D-Sub (male)	25 pins	-
			44 pins	High density
	SPnT = R591 4 and 6 positions	Micro-D receptacle (female)	9 pins	-
TITANIUM SPnT	SPnT = R514 4 and 6 positions	HE10 ribbon receptacle (male)	16 pins	Delivered with ribbon cable 750 mm (30 inches) + HE10 connector (female)
PLATINUM SPnT	SPnT = R594 4 and 6 positions			

## Notes

1. Terminated RAMSES and PLATINUM SPDT are included in R585 and R595.



Introduction

**GLOSSARY (CONTINUED)**

**Polarity:** A common negative polarity is chosen by Radiall for its standard products. An inverted polarity (common plus) is available on RAMSES range; contact Radiall for availability.

**RF Power Chart:** The RF power rating is the capability of handling RF power (CW power) through closed contacts. The RF power should be removed during switching. Power ratings assume unity V.S.W.R. (matched load) at room temperature (25 °C), sea level pressure (14.7 p.s.i.) and cold switching. See below the CW power capability vs. Frequency Chart. Changes in these specifications require power derating (see derating factor versus V.S.W.R.).

This graph is based on the following conditions:

- Ambient temperature: +25 °C
- Sea Level
- V.S.W.R.: 1:1 and cold switching

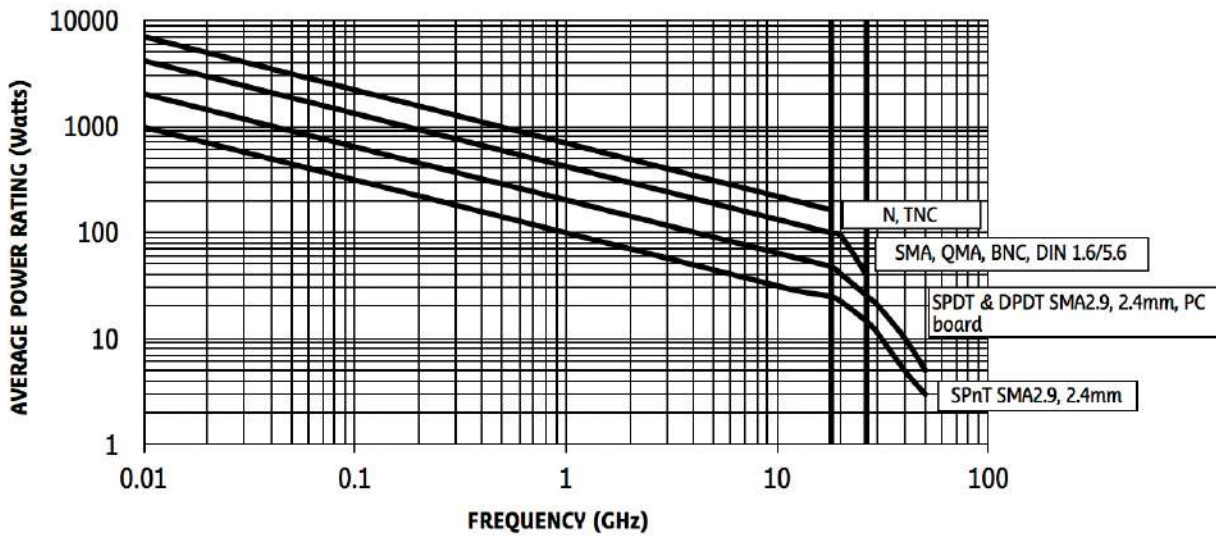

**Derating Factor:** The average power input must be reduced for load V.S.W.R. above 1:1.

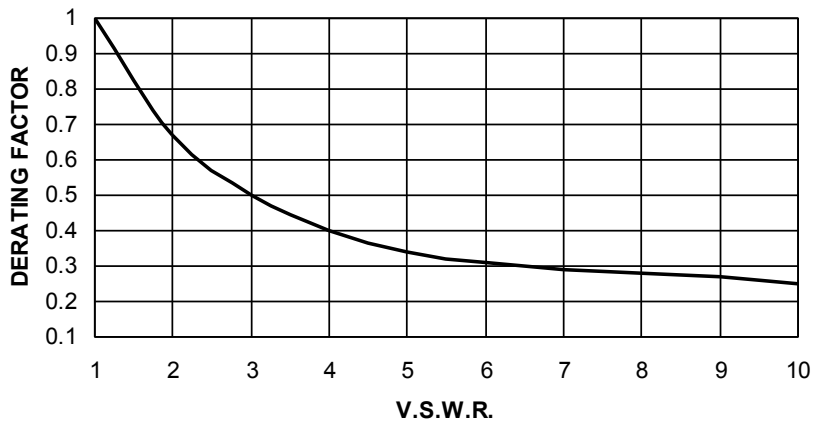

Notes

For PLATINUM and TITANIUM series, common plus polarity potential is chosen for its standard products.

## Introduction

**GLOSSARY (CONTINUED)**

**Peak Power Handling:** The maximum peak power, when applied at room temperature under a pulse of one microsecond every millisecond, will not permanently change the specifications of the switch. Power applied over this limit will alter the RF performance of the switch.

**Repeatability:** The maximum standard deviation in insertion loss specifications on each path over the life of the product. Insertion loss repeatability is specified for all PLATINUM series (0.03 dB over 10 million) and all TITANIUM series (0.03 dB over 2.5 million).

**RF Connectors:** RF connectors are 50 or 75 Ohms female, unless otherwise specified. The applicable mating dimensions, materials and finish are in accordance with applicable sections of international standard (MIL C 39012, DIN 47295). NB RADIAL 75 Ohm coaxial switches are only available with DIN 1.6/5.6 (screw, snap and slide connector) and mini SMB RF connectors.

**Self Cut-Off:** The ability of a switch to disconnect the actuator voltage as soon as the switching of the position is carried out. The system applies to latching relays and is achieved with solid state circuitry. Self Cut-Off time for our RAMSES coaxial switches is from 40 ms to 120 ms.

**Solder Pin:** RAMSES relays are equipped with solder pins for the control and indicator contacts. The maximum temperature during soldering should not exceed 250 °C for 30 seconds or 300 °C for 10 seconds for lead-free soldering process.

**Suppression Diodes:** Diodes connected in parallel with the coil of a switch to suppress transient voltage generated by the self inductance of the coil during the driver signal cut-off. This option is systematically enclosed in all TTL, SELF CUT-OFF and all electronic interfaces.

**Switching Time:** The total amount of time between applying voltage to the actuator terminals and the completion of switching (including all contact bounce — if any). Total switching time consists of three parts, namely inductive delay in the actuator coil, transfer time of the RF contacts, and bounce time of the RF contacts.

**TTL Driver Interface:** The interface of an electronic circuit which enables driving either relays or switches by TTL logic signals. Products equipped with this option have a pin for the voltage of the actuator (12 V or 28 V) as well as a TTL driver pin shared per position. The polarity is not relevant to applications for switches with this option. The logic used is positive, therefore high level nominal +5 V (2.2 to 5.5 V) of TTL signal means logic "1" which enables the corresponding microwave way. Low level i.e logic contacts 0, voltage is 0-0.8 V. Selected position of switches with TTL driver are controlled by a TTL high level.

**V.S.W.R.:** The Voltage Standing Wave Ratio is a measure of the return loss or level of the reflected signal of a device connected on a transmission line. V.S.W.R. is linked to the coefficient of reflection ( $r$ ) by the equation:

$$VSWR = \frac{1+|r|}{1-|r|} \quad r = \frac{Z-Z_0}{Z+Z_0}$$

V.S.W.R. varies from 1 to  $\infty$ , a value equal to 1 represents a perfect matching where:

- " $r$ " is the coefficient of reflection.
- " $Z_0$ " is the characteristic impedance of the line.
- " $Z$ " is the impedance of the line.

Introduction

**RF REPEATABILITY & LIFE TEST PARAMETERS**

Radiall has built an Automatic Test Bench composed by a Vector Network Analyzer (VNA), Digital Multi-Meters (DMM), PC and a switch driver. This approach is to qualify over the complete life of the switch (2.5 million to 10 million cycles depending on switch models). This ATE extracts and stores the RF parameters or contacts resistances of the switch according to our own internal procedure. For each frequency point a calculation of VSWR, insertion loss and standard deviation are computed. All measurements are performed at room temperature (RF switch is toggled at 3 Hz).

The curves in 3D illustrate the RF characteristics over 10 million switching cycles on SP6T-26.5 GHz RAMSES switch.

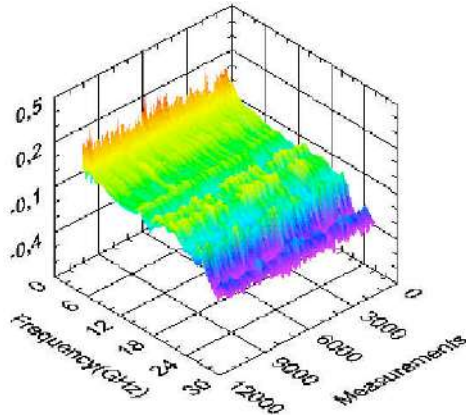

Insertion loss over 10 million cycles

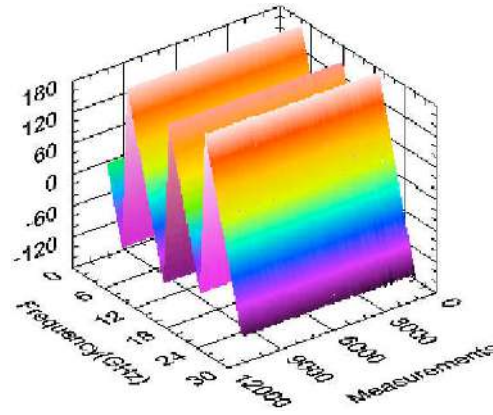

Phase over 10 million cycles

The contribution due to only Rc can be calculated as follows:

$$RL = 20 \text{ LOG}_{10} \left[ \frac{Rc}{2 Ro + Rc} \right]$$

$$VSWR = 1 + \frac{Rc}{Ro}$$

$$IL = 10 \text{ LOG}_{10} \left[ \frac{Ro}{Ro + Rc} \right]$$

The following curve shows RF contact resistance up to 10 million. Switch was toggled at 3Hz with Rc recorded each 50 cycles.

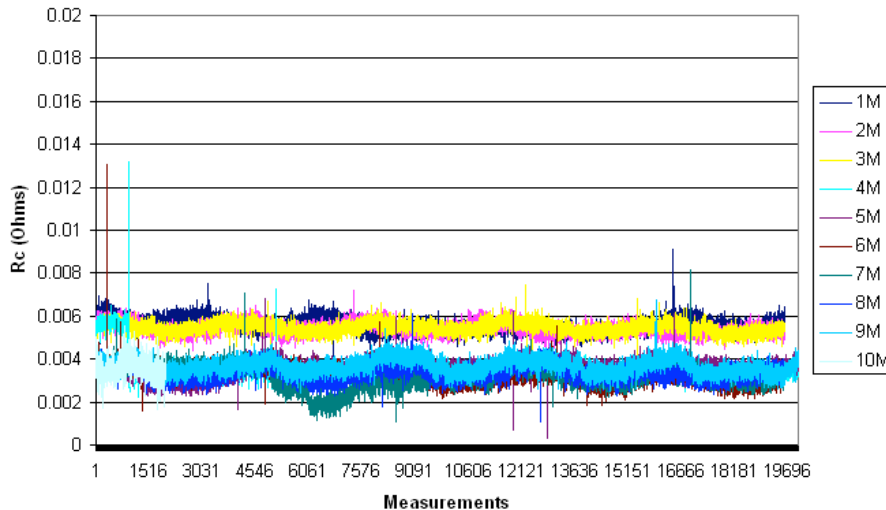

## Introduction

**CONVERSIONS****CONVERSION MEASUREMENT UNIT**

- Convert inch to millimeters: 1 in = 25.4 mm/1 m = 39.3 in
- Convert centimeters to feet: 1 ft = 30.40 cm/1 m = 3.28 ft
- Convert kilogram to pounds: 1 kg = 2.20 Lb/1 lb = 0.45 kg

**REFLECTION COEFFICIENT RETURN LOSS CONVERSION**

- Reflection coefficient ( $\rho$ )
- Standard wave ratio  $(1 + \rho) / (1 - \rho)$
- Return loss (dB)  $(-20 \log_{10} \rho)$

REFLECTION COEFFICIENT	V.S.W.R.	RETURN LOSS (dB)	REFLECTION COEFFICIENT	V.S.W.R.	RETURN LOSS (dB)
0	1.00	$\infty$	0.195	1.48	14.2
0.01	1.02	40.0	0.2	1.5	14.0
0.015	1.03	36.5	0.205	1.52	13.8
0.02	1.04	34.0	0.21	1.53	13.6
0.025	1.05	32.0	0.215	1.55	13.4
0.03	1.06	30.5	0.22	1.56	13.2
0.035	1.07	29.1	0.225	1.58	13.0
0.04	1.08	28.0	0.23	1.6	12.8
0.045	1.09	26.9	0.235	1.61	12.6
0.046	1.10	26.7	0.24	1.63	12.4
0.05	1.11	26.0	0.245	1.65	12.2
0.055	1.12	25.2	0.25	1.67	12.0
0.06	1.13	24.4	0.255	1.68	11.9
0.065	1.14	23.7	0.26	1.7	11.7
0.07	1.15	23.1	0.265	1.72	11.5
0.075	1.16	22.5	0.27	1.74	11.4
0.08	1.17	21.9	0.275	1.76	11.2
0.085	1.19	21.4	0.28	1.78	11.1
0.09	1.20	20.9	0.285	1.80	10.9
0.095	1.21	20.4	0.29	1.82	10.8
0.1	1.22	20.0	0.295	1.84	10.6
0.105	1.23	19.6	0.3	1.86	10.5
0.11	1.25	19.2	0.305	1.88	10.3
0.115	1.26	18.8	0.31	1.90	10.2
0.12	1.27	18.4	0.32	1.94	9.9
0.125	1.29	18.1	0.33	1.99	9.6
0.13	1.30	17.7	0.34	2.03	9.4
0.135	1.31	17.4	0.35	2.08	9.1
0.14	1.33	17.1	0.36	2.13	8.9
0.145	1.34	16.8	0.37	2.17	8.6
0.15	1.35	16.5	0.38	2.23	8.4
0.155	1.37	16.2	0.39	2.28	8.2
0.16	1.38	15.9	0.4	2.33	8.0
0.165	1.4	15.7	0.41	2.39	7.7
0.17	1.41	15.4	0.42	2.45	7.5
0.175	1.42	15.1	0.43	2.51	7.3
0.18	1.44	14.9	0.44	2.57	7.1
0.185	1.45	14.7	0.45	2.64	6.9
0.19	1.47	14.4	0.5	3.00	6.0

Introduction

**POWER CONVERSION**

$dBm = 10 \times \text{Log}_{10} P$  (milliwatts)

$P$  (milliwatts) =  $10^{(dBm/10)}$

POWER (dBm)	POWER (W)	POWER (dBm)	POWER (W)
-49	0.01 μW	1	1.26 mW
-48	0.02 μW	2	1.58 mW
-47	0.02 μW	3	2.00 mW
-46	0.03 μW	4	2.51 mW
-45	0.03 μW	5	3.16 mW
-44	0.04 μW	6	3.98 mW
-43	0.05 μW	7	5.01 mW
-42	0.06 μW	8	6.31 mW
-41	0.08 μW	9	7.94 mW
-40	0.10 μW	10	10 mW
-39	0.13 μW	11	12.59 mW
-38	0.16 μW	12	15.85 mW
-37	0.20 μW	13	19.95 mW
-36	0.25 μW	14	25.12 mW
-35	0.32 μW	15	31.62 mW
-34	0.40 μW	16	39.81 mW
-33	0.50 μW	17	50.12 mW
-32	0.63 μW	18	63.10 mW
-31	0.79 μW	19	79.43 mW
-30	1 μW	20	100 mW
-29	1.26 μW	21	125.89 mW
-28	1.58 μW	22	158.49 mW
-27	2 μW	23	199.53 mW
-26	2.51 μW	24	251.19 mW
-25	3.16 μW	25	316.23 mW
-24	3.98 μW	26	398.11 mW
-23	5.01 μW	27	501.19 mW
-22	6.31 μW	28	630.96 mW
-21	7.94 μW	29	794.33 mW
-20	10 μW	30	1 W
-19	12.59 μW	31	1.26 W
-18	15.85 μW	32	1.58 W
-17	19.95 μW	33	2 W
-16	25.12 μW	34	2.51 W
-15	31.62 μW	35	3.16 W
-14	39.81 μW	36	3.98 W
-13	50.12 μW	37	5.01 W
-12	63.10 μW	38	6.31 W
-11	79.43 μW	39	7.94 W
-10	100.00 μW	40	10 W
-9	125.89 μW	41	12.59 W
-8	158.49 μW	42	15.85 W
-7	199.53 μW	43	19.95 W
-6	251.19 μW	44	25.12 W
-5	316.23 μW	45	31.62 W
-4	398.11 μW	46	39.81 W
-3	501.19 μW	47	50.12 W
-2	630.96 μW	48	63.10 W
-1	794.33 μW	49	79.43 W
0	1 mW	50	100 W

Introduction

**CONVERSIONS (CONTINUED)**  
**TEMPERATURE EQUIVALENCE**

Temp (°C) = (( °F - 32 ) x 5 ) / 9

Temp (°F) = (( 9 x °C ) / 5) + 32

°C	°F	°C	°F	°C	°F
-80	-112.0	22	71.6	73	163.4
-70	-94.0	23	73.4	74	165.2
-60	-76.0	24	75.2	75	167.0
-50	-58.0	25	77.0	76	168.8
-45	-49.1	26	78.8	77	170.6
-40	-40.0	27	80.6	78	172.4
-35	-31.0	28	82.4	79	174.2
-30	-22.0	29	84.2	80	176.0
-25	-13.0	30	86.0	81	177.8
-20	-4.0	31	87.8	82	179.6
-19	-2.2	32	89.6	83	181.4
-18	-0.4	33	91.4	84	183.2
-17	1.4	34	93.2	85	185.0
-16	3.2	35	95.0	86	186.6
-15	5.0	36	96.8	87	188.8
-14	6.8	37	98.6	88	190.4
-13	8.6	38	100.4	89	192.2
-12	10.4	39	102.2	90	194.0
-11	12.2	40	104.0	91	195.8
-10	14.0	41	105.8	92	197.6
-9	15.8	42	107.6	93	199.4
-8	17.6	43	109.4	94	201.2
-7	19.4	44	111.2	95	203.0
-6	21.2	45	113.0	96	204.8
-5	23.0	46	144.8	97	206.6
-4	24.8	47	116.6	98	208.4
-3	26.6	48	118.4	99	210.2
-2	28.4	49	120.2	100	212.0
-1	30.2	50	122.0	105	221.0
0	32.0	51	123.8	110	230.0
1	33.8	52	125.6	115	239.0
2	35.6	53	127.4	120	248.0
3	37.4	54	129.2	130	266.0
4	39.2	55	131.0	140	284.0
5	41.0	56	132.8	150	302.0
6	42.8	57	134.6	160	320.0
7	44.6	58	136.4	170	338.0
8	46.4	59	138.2	180	356.0
9	48.2	60	140.0	190	374.0

°C	°F	°C	°F	°C	°F
10	50.0	61	141.8	200	392.0
11	51.8	62	143.6	250	482.0
12	53.6	63	145.4	300	572.0
13	55.4	64	147.2	350	662.0
14	57.2	65	149.0	400	752.0
15	59.0	66	150.8	500	932.0
16	60.8	67	152.6	600	1112.0
17	62.6	68	154.4	700	1292.0
18	64.4	69	156.2	800	1472.0
19	66.2	70	158.0	900	1652.0
20	68.0	71	159.8	1000	1832.0
21	69.8	72	161.6	-	-

**DERATING TEMPERATURE INFORMATION**

The temperature at which the switches are used has an effect on the coil resistance. This is due to the temperature and variation of the resistivity of copper and the pick up voltage.

Formula of the variation of coil resistance versus the temperature is:

- $R' = R (1 + K (t' - t))$
- $K =$  Temperature coefficient (0.0038 for copper)
- $R =$  Coil resistance (ohms) at temperature  $t$  ( °C)
- $R' =$  Coil resistance (ohms) at temperature  $t'$  ( °C)

**Example of calculation:**

Device: SPDT Failsafe R570413000

How to calculate current at 70 °C with this relay?

In reference to specifications outlined in the technical data sheet:

- Coil resistance 275 Ohms at 25 °C ( $R = 275, t = 25, t' = 70$ )
- Nominal current = 102 mA at 25 °C
- Nominal voltage = 28 volts

New coil resistance at 70 °C will be:

- $R' = 275 ( 1 + 0.0038 (70 - 25))$
- $R' = 275 \times 2.71$
- $R' = 323$  Ohms

According to the Ohm law ( $U = R I$ ), at 70 °C:

- $U = R \times I$
- $I = 87$  mA

Introduction

**COIL RESISTANCE VALUE VERSUS TEMPERATURE**

The following graphs are examples of calculation for the same product R570413000 (SPDT SMA).

**MAXIMUM PICK UP VOLTAGE VERSUS TEMPERATURE**

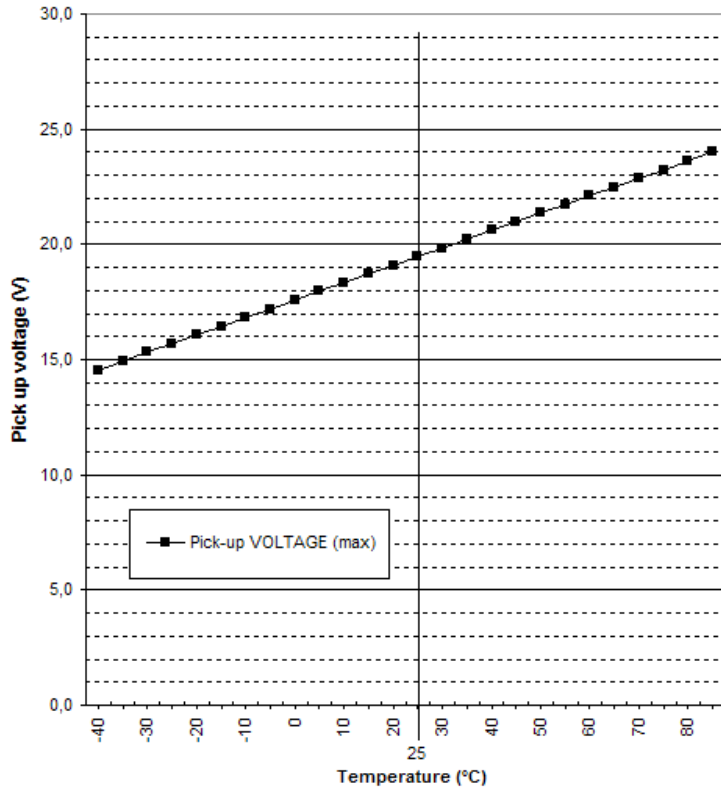

**CURRENT VALUE VERSUS VOLTAGE OVER TEMPERATURE RANGE**

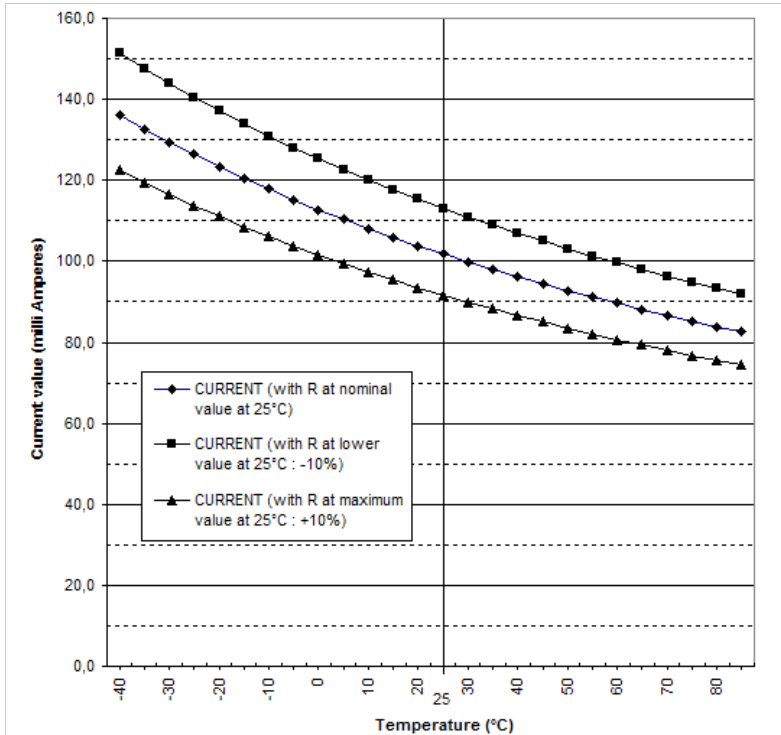

For customer support and more technical information contact a Radiall sales representative.

Introduction

### CONVERSIONS (CONTINUED)

#### COIL RESISTANCE VALUE VERSUS TEMPERATURE

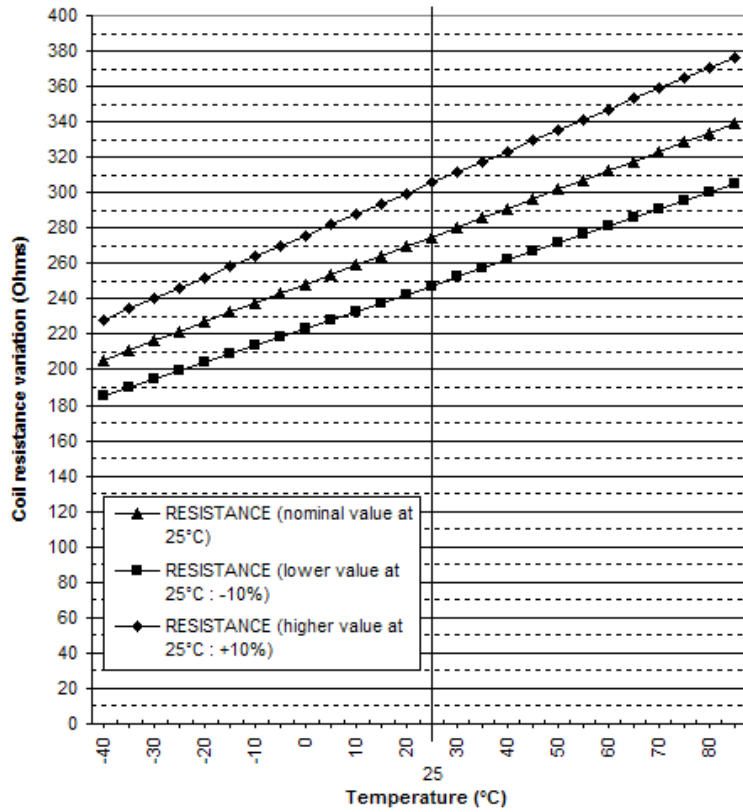

#### MAXIMUM PICK UP VOLTAGE VARIATION VERSUS TEMPERATURE

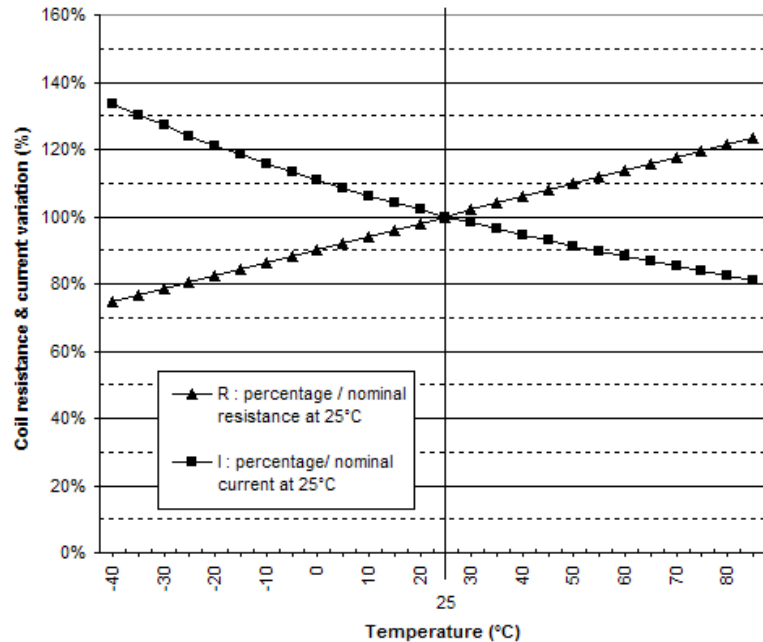



Introduction

**USER HANDBOOK  
FOR CONNECTOR ASSEMBLY ON COAXIAL SWITCHES**

When connecting RF coaxial connectors to Radiall switches precaution should be taken to avoid irreversible damage on the RF switches.

*Use only connectors with the correct interface dimensions.*

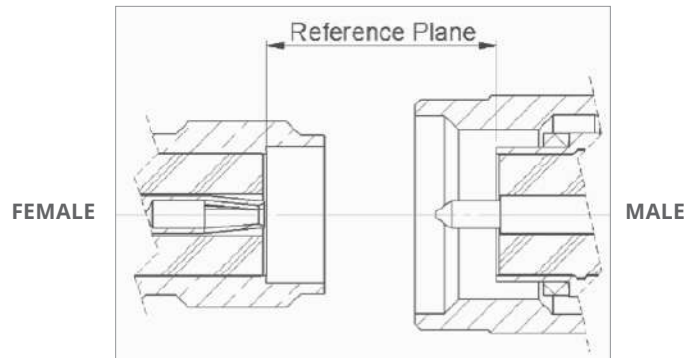

To ensure appropriate torque on the connector, and avoid damage on the contacts it is recommended to use a specific tool with calibrated torque. Apply the recommended torque as shown below:

SMA CONNECTORS	TNC CONNECTORS
from 80 to 120 N.cm	265 N.cm

*Connection of semi-rigid cable using the center contact of the cables as pin for connecting the female connector.*

If the center contact is not in alignment with the female socket, the switch RF connector could be damaged.

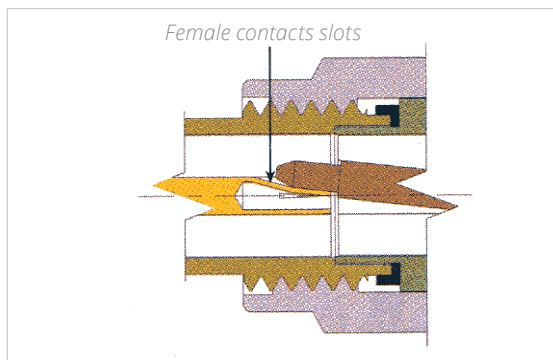

**FIG A: MISALIGNED PIN BETWEEN INSULATOR & FEMALE CONTACTS SLOTS**

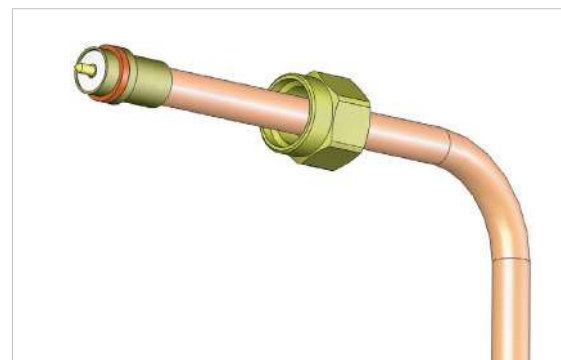



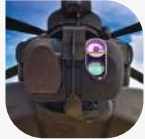

**FIG B: SEMI-RIGID CABLE WITH REMOVABLE NUT SMA CONTACT**

RF connectors with removable nut allow visual confirmation that the center contact is correctly positioned.

CABLE	CONNECTOR
0.085	R125 052 500
0.141	R125 055 500

Introduction

APPLICATIONS

APPLICATIONS	QUARTZ	RAMSES & USB SERIES	TITANIUM	PLATINUM	TVAC PRODUCTS	SPACE COMPONENTS
Instrumentation 	Automated test					N/A
	Measurement equipments					
	Monitoring devices					
	Test network					
Wireless communication 	Telecommunication				N/A	
	Tower mount amplifiers					
	BTS					
	Radio links					
	ECM equipments					
	Repeaters					
	Base stations					
	Point to point link					
Military 	Military radios				N/A	
	Electronic warfare					
	Radar					
Space 	Pay load: N/A					Pay load: Various satellites Communication Observation
	Ground segment					
	Test equipments					
	Earth stations					

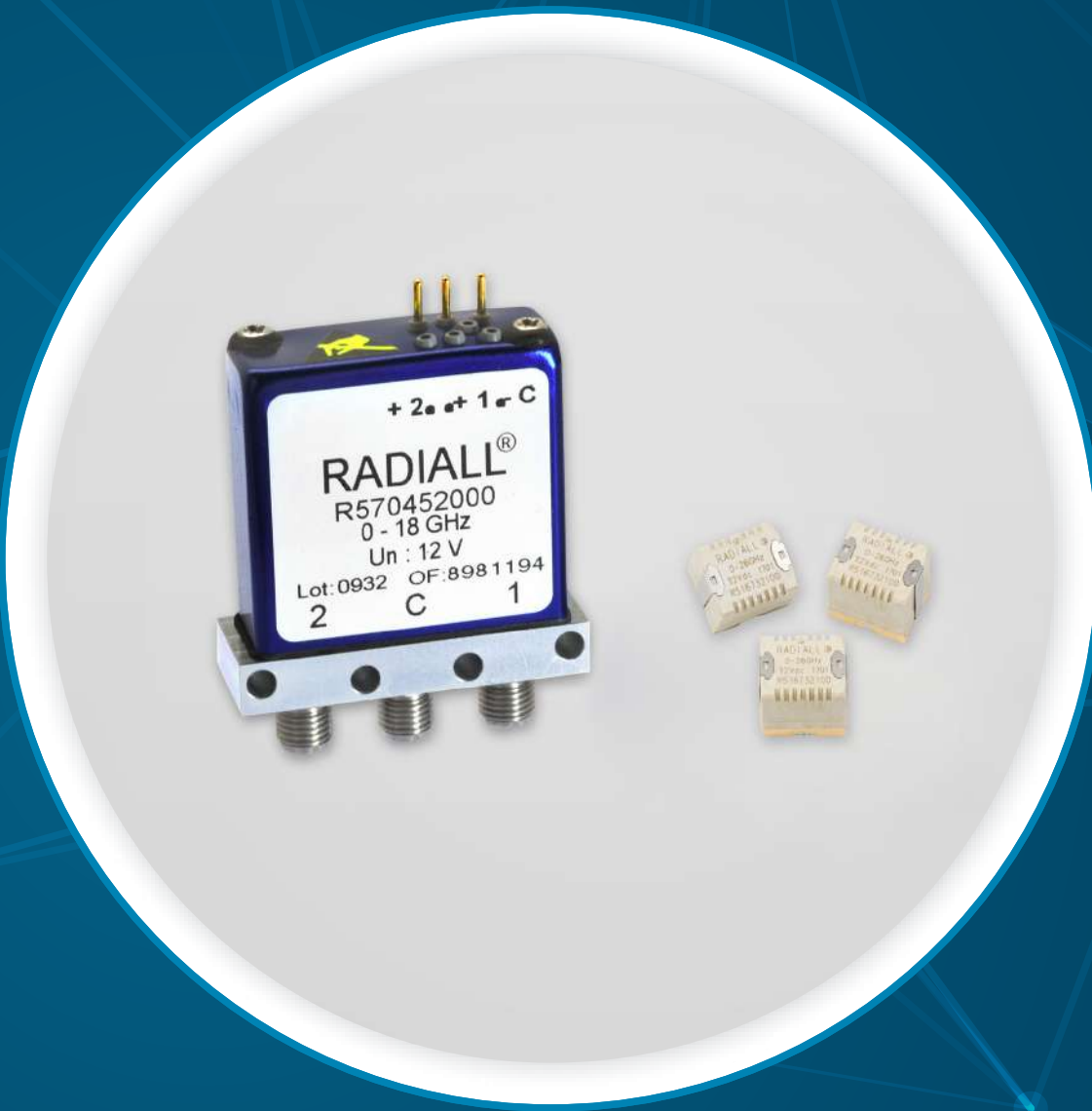

## SPDT

---



Section 2 Table of Contents

**QUARTZ SERIES**

SMT Power Micro-SPDT with  
26.5 GHz capabilities: R516 Series ..... 2-2 to 2-8  
Applications ..... 2-9

**RAMSES SERIES**

SPDT up to 50 GHz:  
R570 Series (miniature models) ..... 2-10 to 2-15  
SPDT up to 18 GHz:  
R570 Series (N, BNC and TNC models) ..... 2-16 to 2-19

**ELECTRICAL SCHEMATICS**

Coaxial SPDT: R570 Series ..... 2-20 to 2-23

**PLATINUM SERIES**

High Performance SPDT up to 40 GHz:  
R595 Series ..... 2-24 to 2-29

**OPTIONAL FEATURES**

Optional Features ..... 2-30

**SPDT PART NUMBER SELECTION GUIDE<sup>[1]</sup>**

Quartz SPDT	RAMSES SPDT	PLATINUM SPDT	Series Configuration	DIGITAL POSITION
R516	R570	R595	-	R: 1-3
3	-	-	DC - 8 GHz	<b>4: RF CONNECTORS</b>
4	-	-	DC - 18 GHz	
7	-	-	DC - 26.5 GHz	
-	3	-	SMA 3 GHz	
-	-	3	SMA 6 GHz	
-	4	-	SMA 18 GHz	
-	-	4	SMA 20 GHz	
-	F	F	SMA 26.5 GHz	
-	8	8	SMA 2.9 40 GHz	
-	J	-	2.4mm 50 GHz	
-	E	-	QMA 6 GHz	
-	9	-	DIN 1.6/5.6, 2.5 GHz	
-	H	-	-	
-	A	-	Pc board mount 3 GHz	
-	0	-	N 3 GHz	
1	1	-	N 12.4 GHz	
2	2	-	BNC 3 GHz	
-	5	-	TNC 3 GHz	
-	6	-	TNC 12.4 GHz	
-	D	-	TNC 18 GHz	
1/9	1/2	-	Failsafe	<b>5: TYPE</b>
3	3/4/5/6	3/4/5/6	Latching	
1	-	-	6 V	
2	2	-	12 V	
-	-	7	15 V	
3	-	3	24 V	
-	3	-	28 V	
-	0	-	Without	
-	1	-	With	
-	-	1	SPDT non-terminated	
1	-	-	-	
-	0	1	Without option	
-	1	1	Positive common	
-	3	-	Suppression diodes	
-	4	-	Suppression diodes and positive common	
-	-	2	Compatible with TTL driver	
0	-	-	-	
0	-	-	Not soldered	
T	-	-	Soldered on a connectorized test fixture	
-	0	0	Solder pins	
-	5	-	D-Sub connector	
-	-	-	Certificate of conformity	
-	-	-	Calibration certificate	
-	-	R	Calibration certificate + RF curves	
-	-	-	-	

**Notes**

Example of P/N: R570F12010 is a SPDT SMA 26.5 GHz, failsafe, 12 Vdc, without TTL, with positive common, solder pins.

1. For part number creation and available options, see detailed part number selection for each series.

## SMT POWER MICRO SPDT WITH 26.5 GHz CAPABILITIES SURFACE MOUNT TECHNOLOGY

An innovative and original "micro-mechanical" design of the R516 SMT micro-relay offers excellent RF performance, reliability, and repeatability. The miniature size and low installation cost make these coaxial switches an ideal solution.

Very low return loss and insertion loss allow this relay to be used in power applications, as well as in typical SMT relay applications such as RF attenuators, RF matrices, spectrum analysers, and telecommunications.

Failsafe models are offered in two RF configurations (direct and inverted). The association of these two products on the same PC board enables the product to perform the bypass function. (For bypass mounting, further information is available on page 2-7.)



### Example of P/N:

R516713100 is a SPDT SMT 26.5 GHz, 24 Vdc, failsafe, not soldered.

### ACTUAL SIZE

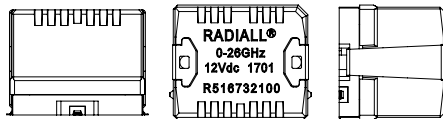

### TYPICAL OUTLINE DRAWING

All dimensions are in millimeters [inches].

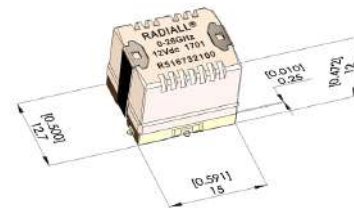

### PART NUMBER SELECTION

SERIES PREFIX \_\_\_\_\_

FREQUENCY RANGE \_\_\_\_\_

3: DC – 8 GHz

4: DC – 18 GHz

7: DC – 26.5 GHz

TYPE \_\_\_\_\_

1: Failsafe

3: Latching, 2 coils

9: Failsafe, inverted RF path <sup>[1]</sup>

R516

10

### ACTUATOR TERMINALS

0: Not soldered

T: Soldered on a connectorized test fixture <sup>[2]</sup>

### ACTUATOR VOLTAGE

1: 6 Vdc <sup>[3]</sup>

2: 12 Vdc

3: 24 Vdc

### Notes:

1. Can be combined with a failsafe model, so as to achieve the "BYPASS" function (see application details on page 2-6).

2. See details about test fixture dimensions on page 2-4.

3. Only available with type 3.

Quartz Series

**QUARTZ GENERAL SPECIFICATIONS**

OPERATING MODE		FAILSAFE (TYPES 1 & 9)		LATCHING (TYPE 3)		
Nominal operating voltage (across temperature range)	Vdc	12 (10.5 to 13)	24 (21.5 to 30)	6 (5.1 to 6.6)	12 (10.2 to 13)	24 (20.5 to 30)
Coil resistance at 23 °C (+/- 10%)	Ω	195	710	55	205	865
Operating current at 23 °C	mA	61	32	108	58	32
RF and command ports		Gold-plated access, infrared reflow, forced air oven or hand soldering (Compatible with "lead free" soldering processes)				
Switching time at nominal voltage - Making contacts - Breaking contacts		Max 5 ms (typical 2 ms), including contact bounce time 3 ms				
Life - Cold switching (max 120 cycles/min) - Hot switching (max 20 cycles/min)		2 million cycles		3 million cycles (5 million cycles typical at low level)		
		500.000 cycles				
Insulation		Dielectric test voltage		300 Vrms		
		Insulation resistance at 500 Vdc		> 100 MOhms		
Environmental protection		Lead free construction - Waterproof (acc. To IEC 60529 / IP64)				
Mass		8 g				
Operating temperature range (with no icing nor condensation)	°C	-25 to +70 [1]		-40 to +85		
Storage temperature range	°C	-55 to +85				
Sine vibration (MIL STD 202, Method 204D)		Condition D: 10-2,000 Hz, 20 g		Operating		
		Condition G: 10-2,000 Hz, 30 g		Non-operating		
Shocks (According to MIL STD 202, Method 213B, Cond. C)		100 g / 6 ms, 1/2 sine		Operating		

**PIN IDENTIFICATION (TOP VIEW)**

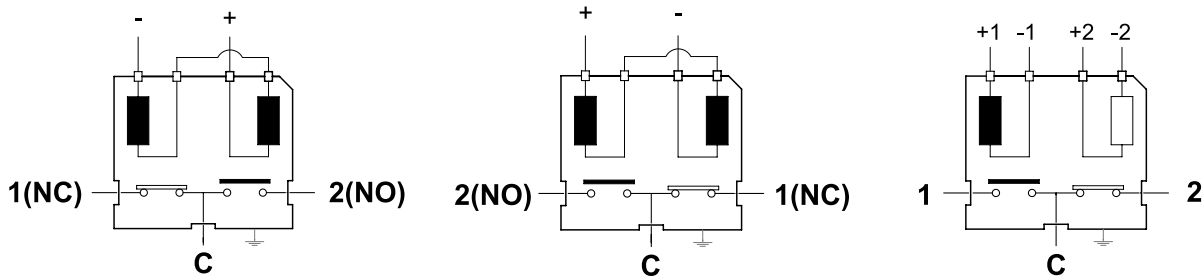

**FAILSAFE MODEL (TYPE 1)**

VOLTAGE	RF CONTINUITY
De-energized	C <--> 1(NC)
Energized	C <--> 2(NO)

**INVERTED FAILSAFE MODEL FOR BYPASS APPLICATION (TYPE 9)**

VOLTAGE	RF CONTINUITY
De-energized	C <--> 1(NC)
Energized	C <--> 2(NO)

**LATCHING MODEL (TYPE 3)**

VOLTAGE	RF CONTINUITY
-1 +1	C <--> 1
-2 +2	C <--> 2

**Notes**

1. Failsafe models may be used down to -40 °C, for this application please follow requirements of AN-R516-51. Contact Radiall for a copy of this application note.

Quartz Series

QUARTZ PERFORMANCE (S PARAMETERS AVAILABLE ON REQUEST)

FREQUENCY RANGE GHz	V.S.W.R. (MAX)	INSERTION LOSS (MAX) dB	ISOLATION (MIN) dB	THIRD ORDER INTER MODULATION	IMPEDANCE $\Omega$	
			SWITCH ALONE			
DC - 8 DC - 18 DC - 26.5	DC - 3	1.20	0.20	50	-110 dBc typical at 1730 MHz (2 carriers 20 W)	50
	3 - 6	1.35	0.40	40		
	6 - 8	1.40	0.50	40		
	8 - 12.4	1.50	0.60	40		
	12.4 - 18	1.70	1.00	40		
	18 - 26.5	2.00	1.60	40		

MEASUREMENT METHOD

RELAY SOLDERED ON TEST FIXTURE<sup>[1]</sup>

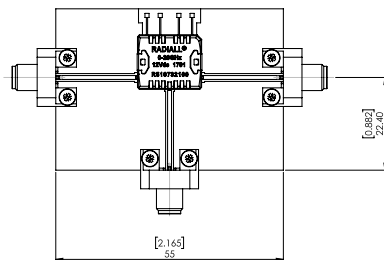

CALIBRATION BOARD

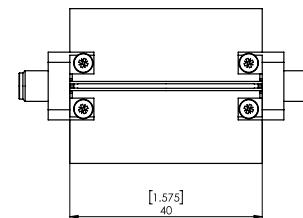

Inputs/Outputs of the calibration board and test fixture are equipped with coaxial type receptacle connectors. The length of the RF tracks is the same on the calibration board and the test fixture circuits. The insertion loss of the relay itself is calculated by subtracting the insertion loss of the "calibration board" to the insertion loss of the "relay soldered on the test fixture."

TYPICAL RF PERFORMANCE

INSERTION LOSS & ISOLATION

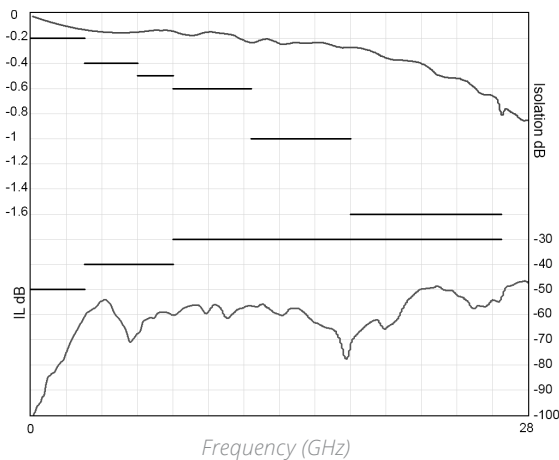

V.S.W.R

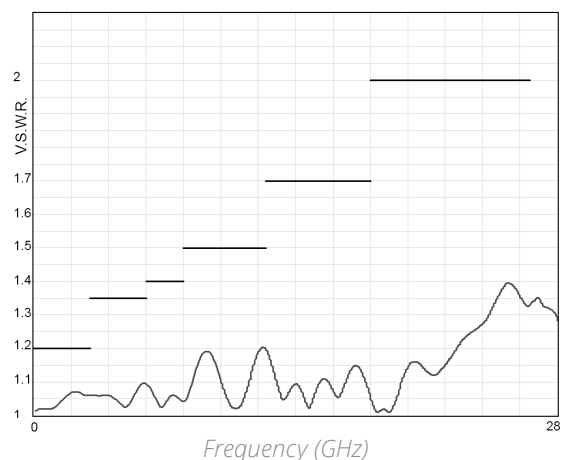

Notes

1. Relay soldered on Test Fixture is available. To order, please use the suffix "T" (part number R516 - - - - T), as explained in page 2-2. All dimensions are in millimeters [inches].



Quartz Series

**RF POWER RATING FOR COLD SWITCHING USE**

(IMPEDANCE 50 OHMS, V.S.W.R. < 1.25)

Power level depends on environmental conditions:

- R516 series have been designed to be used without a cooling fan even for high power applications. However, the power capability may be still improved by using the appropriate cooling fan.
- For failsafe models used with coil permanently supplied (N/O position), the same power level as latching models may be applied.

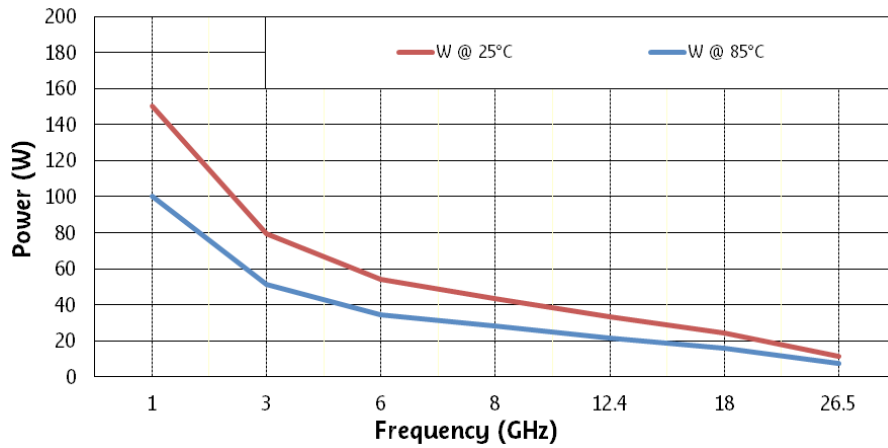

**RELAY PACKAGING**

ACCORDING TO IEC 286-3 STANDARD

Materials:

- Reel: polyester
- Carrier tape: PVC
- Cover tape: polyester

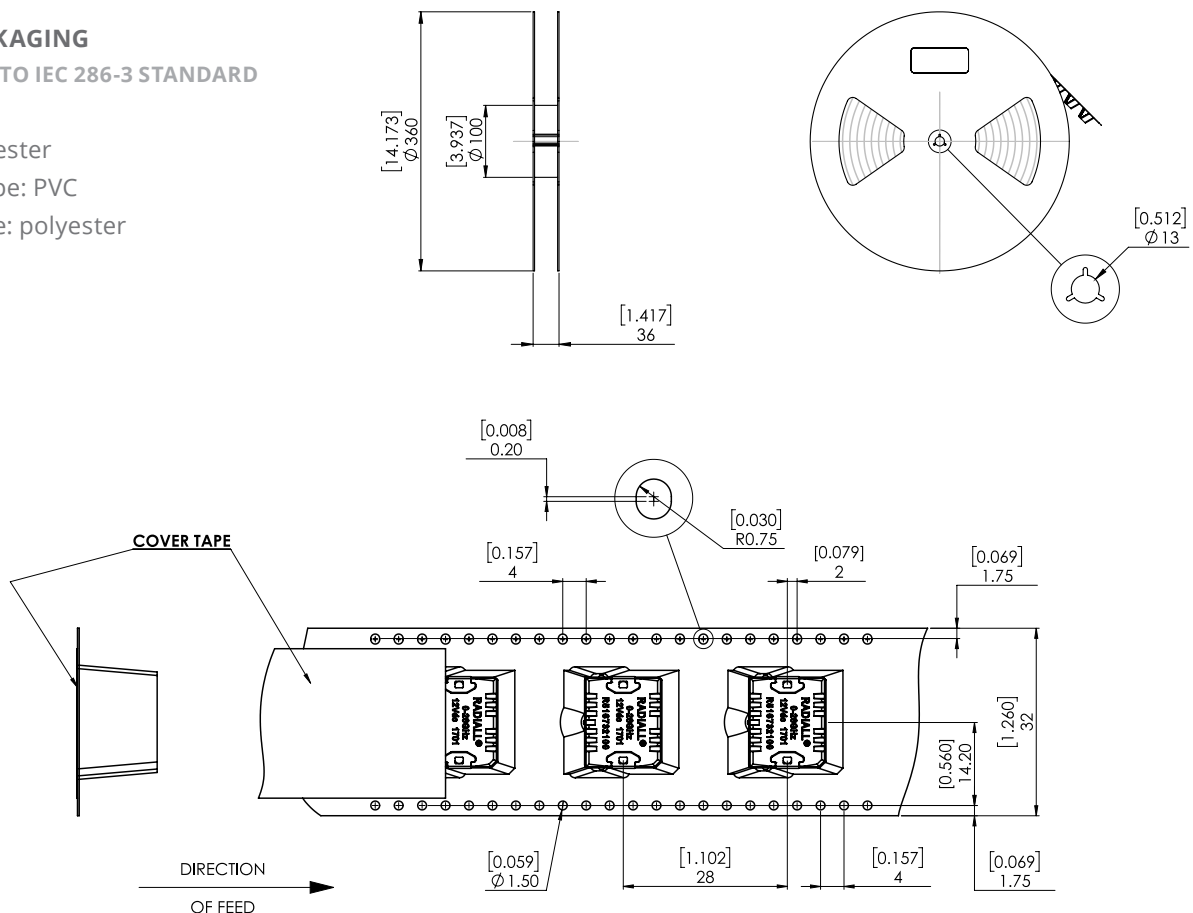

**VIDEO SHADOW OF THE RELAY**

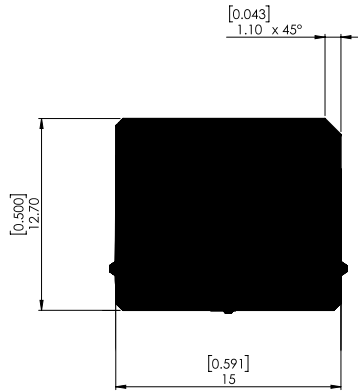

**ASPIRATION AREA**

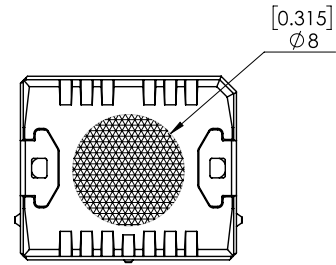

**BYPASS APPLICATION**

**FAILSAFE MICRO-RELAY TYPICAL IMPLANTATION**

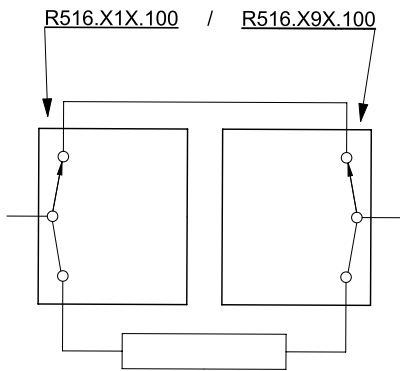

SPDT relays (Single Pole Double Throw) can be used to achieve a bypass switch function. For SMT applications, R516 series, relays are available in two failsafe versions, standard and inverted, to provide symmetric RF ports implantation possibility. The “side by side” implementation of these two versions on a PCB effectively produces the bypass function. The package size is reduced and interconnecting tracks are shortened. Required in order to protect the receiver for transmit/receive applications. RF performance of bypass switch assemblies depend on the distance between the two RF SMT relays.

**Notes**

All dimensions are in millimeters [inches].

Quartz Series

## PC BOARD MOUNTING

### Board layout

DXF or Gerber format file available upon request.

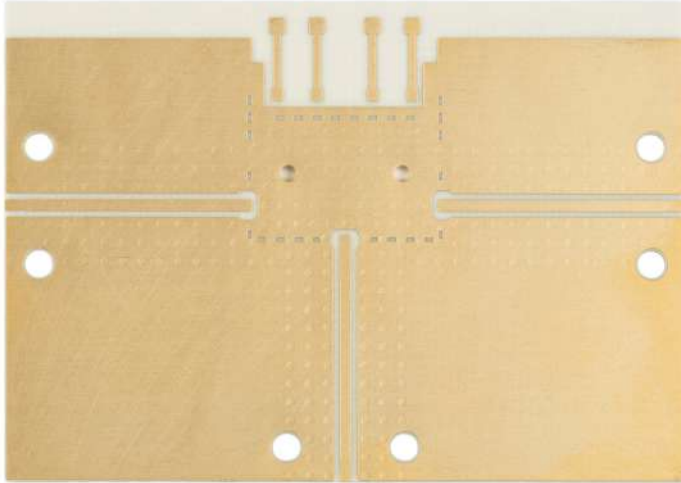

## SUBSTRATE TYPES

**Recommended substrates are ROGERS RO4003.**

Thickness 0.508 mm Cu double side 17.5  $\mu\text{m}$ .

**Recommended total thickness of RF tracks (copper over thickness + plating): 40  $\mu\text{m}$ .**

Other substrates may be used.

### Notes

Please contact your local sales representative for additional information.

## RECOMMENDED SOLDERING PROCEDURE

### A - Soldering procedure using automatic pick and place equipment

**1 - Solder paste:** R516 series are "Lead Free", and Lead Free Sn-Ag3.5-Cu0.7 solder cream may be used as well as standard Sn63-Pb35-Ag2. Radiall recommends using a "no clean - low residue" solder cream (5% solid residue of flux quantity) that will permit the elimination of the cleaning operation step after soldering.

*Note: Due to the gold plating of the switch PCB interface, it is important to use a paste made with silver. This will help in avoiding formation of intermetallics as part of the solder joint.*

**2 - Solder paste deposition:** Solder cream may be applied on the board with screen printing or dispenser technologies. For either method, the solder paste must be coated to appropriate thickness and shapes to achieve good solder wetting. Please optically verify that the edges of the zone are clean and without contaminates, and that the PCB zoned areas have not oxydated. The design of the mounting pads and the stenciling area are available upon request, for a thickness of the silk-screen printing of 0.15 mm (0.006").

**3 - Placement of the component:** For small lightweight components such as chip components, a self-alignment effect can be expected if small placement errors exist. However, this effect is not as expected for relays components and they require an accurate positioning on their soldering pads, typically +/- 0.1 mm (+/-0.004"). Place the relay onto the PCB with automatic pick and place equipment. Various types of suction can be used. Radiall does not recommend using adhesive agents on the component or on the PCB.

**4 - Soldering: infrared process:** Please follow the Radiall recommended max temperature profile for infrared reflow or forced air convection:

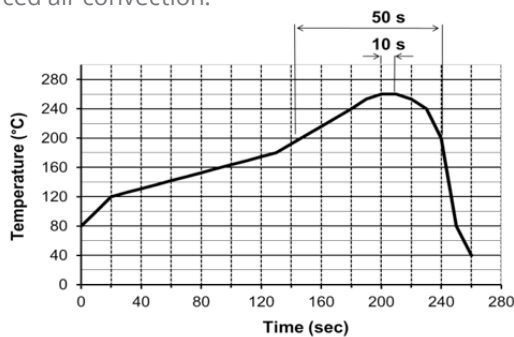

Higher temperature (>260 °C) and longer process duration would permanently damage the switches.

**5 - Cleaning procedure:** On miniature relays, high frequency cleaning may cause the contacts to stick. If cleaning is needed, please avoid ultrasonic cleaning and use alcohol based cleaning solutions.



*In-line cleaning process, spraying, immersion, especially under temperature, may cause a risk of degradation of internal contacts. For such cleaning process please contact us.*

**6 - Quality check:** Verify by visual inspection that the component is centered on the mounting pads. Solder joints: verify by visual inspection that the formation of meniscus on the pads are proper.

### B - Soldering procedure by manual operation



*Manual soldering is not recommended for high frequencies, as it generates resonance and lower RF characteristics due to gaps between PC board and relay grounds.*

**1 - Solder paste and flux deposition:** Refer to procedure A - 1. Deposit a thin layer of flux on solder pad area. Allow the flux to evaporate a few seconds before applying the solder paste, it will prevent dilution of the paste.

**2 - Solder paste deposition:** Radiall recommends depositing a small amount of solder paste on solder pad area by syringe, according to the manual soldering pattern (available upon request.) Be careful not to apply solder paste outside of the zone area.

**3 - Placement of the component:** During manipulation, avoid contaminating gold surfaces by contact with fingers. Place the component on the mounting zone by pressing on the top of the relay lid.

**4 - Hand soldering:** Iron wattage 30 to 60 W. To keep better RF characteristics, apply pressure on the relay lid during all the soldering stage, so as to reduce the air gap between the PC board and the relay. If possible, fix the ground plane of the relay on the board with two M1.2 screws before the soldering stage. On each side of the central RF access, the RF body edge must be soldered to the ground of the PC board. To improve RF characteristics and avoid soldering the RF body to the ground, a conductive gasket may be used (please contact us for detailed application note.)

**5 - Cleaning procedure:** Refer to procedure A - 5.

**6 - Quality check:** Verify by visual inspection that component is centered on the mounting pads. Solder joints: verify by visual inspection that there is no solder excess on the RF pads.

## APPLICATIONS

### PC BOARD MOUNTING

The SMT Series offers a large range of products which can be used in many applications such as:

- Tower mount amplifiers
- Instrumentation
- Military radios
- ECM equipment
- Remote Radio Unit (RRU)
- Radio-Links
- Repeaters

These products offer the same RF Board and soldering process as all RF components but with a reduced weight and size. They are designed to meet all market specifications.

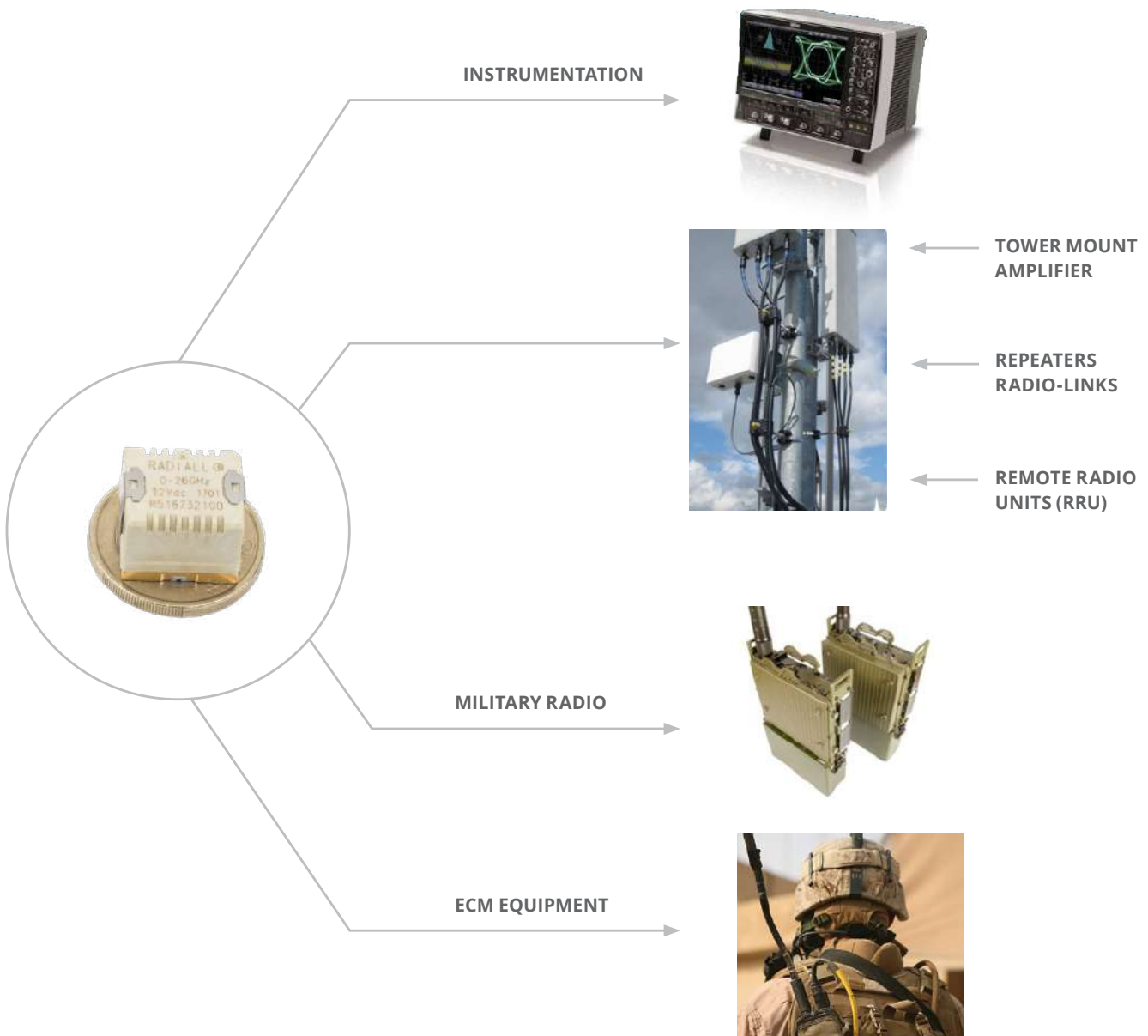

### SPDT UP TO 50 GHz

PC BOARD - SMA - SMA 2.9 - 2.4 MM - QMA - DIN 1.6/5.6



Radiall's RAMSES SPDT switches offer excellent reliability, high performance and operating frequencies from DC to 50 GHz. Radiall's RAMSES concept (which provides for a life span of 10 million cycles) offers a variety of options to meet customer needs.

These switches are dedicated to all market applications including: military, instrumentation and telecommunications.

Example of P/N: R570413100 is a SPDT SMA 18 GHz, failsafe, 28 Vdc, with TTL driver, without option, solder pins.

#### PART NUMBER SELECTION

## R570

**SERIES PREFIX** \_\_\_\_\_

**FREQUENCY RANGE** \_\_\_\_\_

- 3: SMA up to 3 GHz
- E: QMA up to 6 GHz <sup>[5]</sup>
- 4: SMA up to 18 GHz
- F: SMA up to 26.5 GHz
- 8: SMA 2.9 up to 40 GHz <sup>[6]</sup>
- J: 2.4 mm up to 50 GHz
- 9: DIN 1.6/5.6 up to 2.5 GHz
- A: PC board mount up to 3 GHz <sup>[4]</sup>

**TYPE** \_\_\_\_\_

- 1: Failsafe
- 2: Failsafe + I.C.
- 3: Latching
- 4: Latching + I.C.
- 5: Latching + S.C.O. <sup>[1]</sup>
- 6: Latching + S.C.O. + I.C. <sup>[1]</sup>

**ACTUATOR VOLTAGE** \_\_\_\_\_

- 2: 12 Vdc
- 3: 28 Vdc

**ACTUATOR TERMINALS**

0: Solder pins

**OPTIONS**

- 0: Without option
- 1: Positive common <sup>[2 & 3]</sup>
- 3: With suppression diodes <sup>[1]</sup>
- 4: With suppression diodes and positive common <sup>[1, 2 & 3]</sup>

**TTL OPTION**

- 0: Without TTL driver
- 1: With TTL driver <sup>[1 & 2]</sup>

**Notes:**

I.C.: Indicator contact - S.C.O.: Self Cut-Off.

1. Suppression diodes are already included in Self Cut-Off and TTL option.
2. Polarity is not relevant to application for switches with TTL driver.
3. Positive common shall be specified only with type 3, 4, 5, and 6 because failsafe switches can be used with both polarities.
4. Available only upon request.

5. The QLF trademark (Quick Lock Formula®) standard applies to QMA and QN series and guarantees the full intermateability between suppliers using this trademark. Using QLF certified connectors also guarantees the specified level of RF performance.
6. Connector SMA 2.9 is equivalent to "K connector®", registered trademark of Anritsu.



## RAMSES Series

## GENERAL SPECIFICATIONS

OPERATING MODE		FAILSAFE		LATCHING	
Nominal operating voltage (across temperature range)	Vdc	12 (10.2 to 13)	28 (24 to 30)	12 (10.2 to 13)	28 (24 to 30)
Coil resistance at 23 °C (+/-10%)	Ω	47.5	275	58	350
Operating current at 23 °C	mA	250	102	210	80
Average power		See Power Rating Chart page 1-13			
TTL Input	High level	2.2 to 5.5 Volts		800 μA max 5.5 Volts	
	Low level	0 to 0.8 Volts		20 μA max 0.8 Volts	
Indicator rating		1 W / 30 V / 100 mA			
Switching time		ms			
Life	SMA - SMA 2.9 - QMA	10 million cycles			
	DIN 1.6/5.6 - PC Board	5 million cycles			
	2.4 mm	2 million cycles			
Connectors		SMA - SMA 2.9 - QMA - DIN 1.6/5.6 - PC Board - 2.4 mm			
Operating temperature range	DIN 1.6/5.6 - 2.4 mm	-25 °C to +70 °C			
	SMA - SMA 2.9 - QMA - PC Board	-40 °C to +85 °C			
Storage temperature range	DIN 1.6/5.6 - 2.4 mm	-40 °C to +85 °C			
	SMA - SMA 2.9 - QMA - PC Board	-55 °C to +85 °C			
Vibration (MIL STD 202, Method 204D, cond.D)		10-2,000 Hz, 20 g		Operating	
Shock (MIL STD 202, Method 213B, cond.C)		100 g / 6 ms, ½ sine		Operating	

## RF PERFORMANCE

CONNECTORS	FREQUENCY RANGE GHz	V.S.W.R. (MAX)	INSERTION LOSS (MAX) dB	ISOLATION (MIN) dB	IMPEDANCE Ω	
DIN 1.6/5.6	DC - 2.5	DC - 1	1.20	0.20	80	75
		1 - 2.5	1.30	0.30	70	
QMA	DC - 6	DC - 3	1.20	0.20	80	50
		3 - 6	1.30	0.30	70	
SMA	DC - 3 DC - 18 DC - 26.5	DC - 3	1.10	0.15	80	
		3 - 8	1.20	0.20	75	
		8 - 12.4	1.20	0.25	65	
		12.4 - 18	1.40	0.35	60	
SMA 2.9	DC - 40	18 - 26.5	1.50	0.50	55	
		DC - 6	1.30	0.30	70	
		6 - 12.4	1.40	0.40	60	
		12.4 - 18	1.50	0.50	60	
PC Board	DC - 3	18 - 26.5	1.70	0.70	55	
		26.5 - 40	1.90	0.80	50	
2.4 mm	DC - 50	DC - 3	1.20	0.20	80	
		DC - 6	1.30	0.30	70	
		6 - 12.4	1.40	0.40	60	
		12.4 - 18	1.50	0.50	60	
		18 - 26.5	1.70	0.70	55	
		26.5 - 40	1.90	0.80	50	
		40 - 50	1.90	1.10	50	

## Notes

See page 2-12 and 2-13 for typical RF performance.

RAMSES Series

R570 TYPICAL RF PERFORMANCE

Example: SPDT SMA 2.9 up to 40 GHz

INSERTION LOSS & ISOLATION

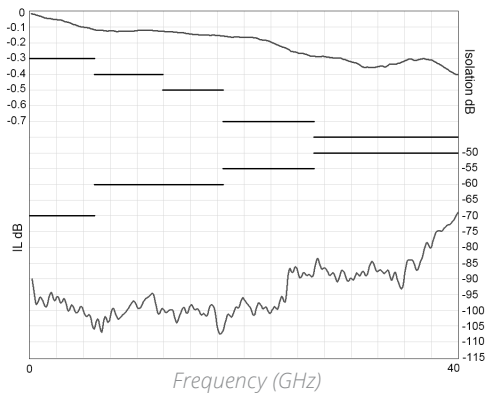

V.S.W.R

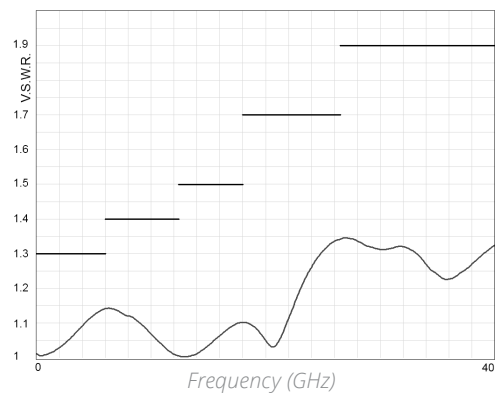

Example: SPDT 2.4 mm up to 50 GHz

INSERTION LOSS & ISOLATION

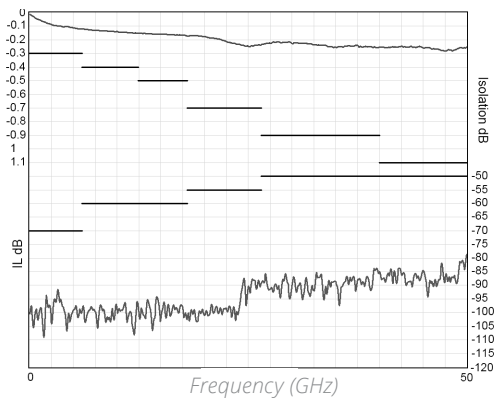

V.S.W.R

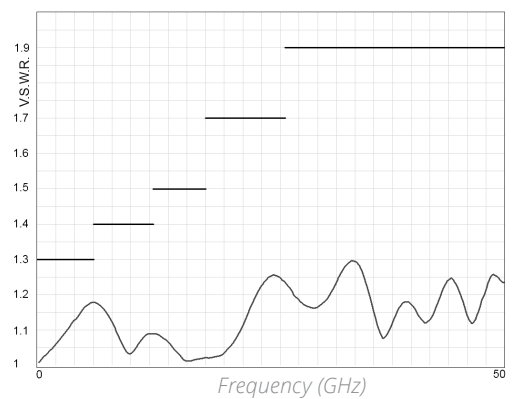

Example: SPDT SMA up to 26.5 GHz

INSERTION LOSS & ISOLATION

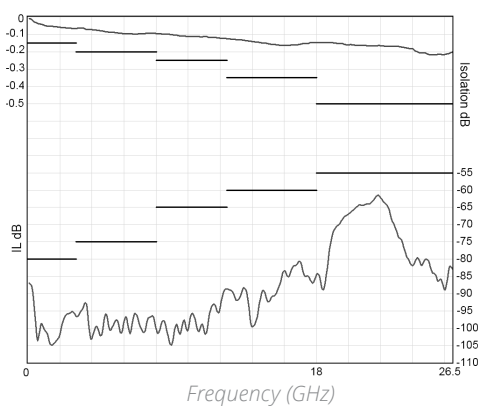

V.S.W.R

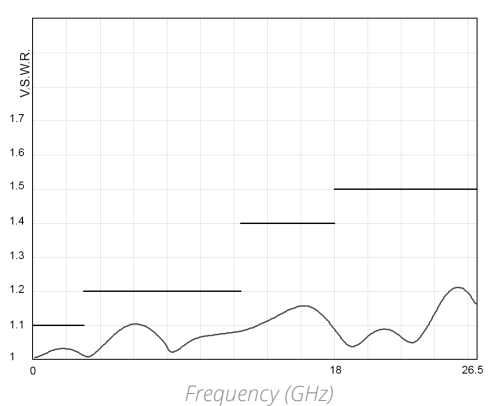



RAMSES Series

**R570 TYPICAL RF PERFORMANCE (CONTINUED)**

*Example: SPDT QMA up to 6 GHz*

**INSERTION LOSS & ISOLATION**

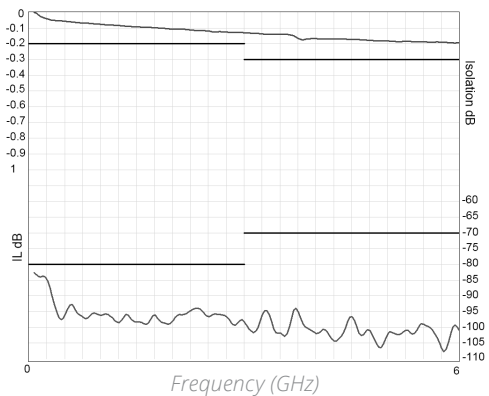

**V.S.W.R**

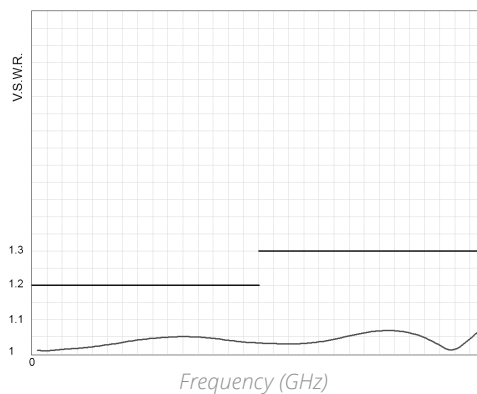

*Example: SPDT DIN 1.6/5.6 up to 2.5 GHz*

**INSERTION LOSS & ISOLATION**

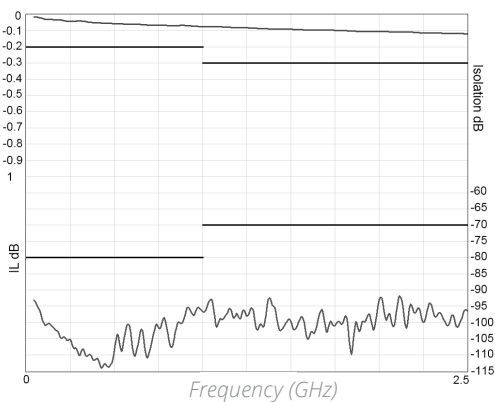

**V.S.W.R**

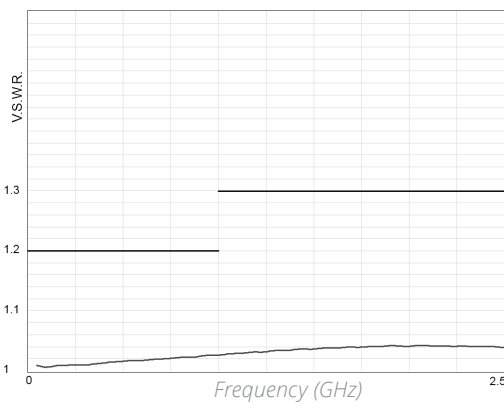

TYPICAL OUTLINE DRAWING

CONNECTORS	A MAX (MM [INCHES])
SMA	7.7 [0.303]
SMA 2.9 and 2.4 mm	6.7 [0.264]
QMA	10.8 [0.394]
DIN 1.6/5.6	11.5 [0.433]
PC Board	4.5 [0.157]

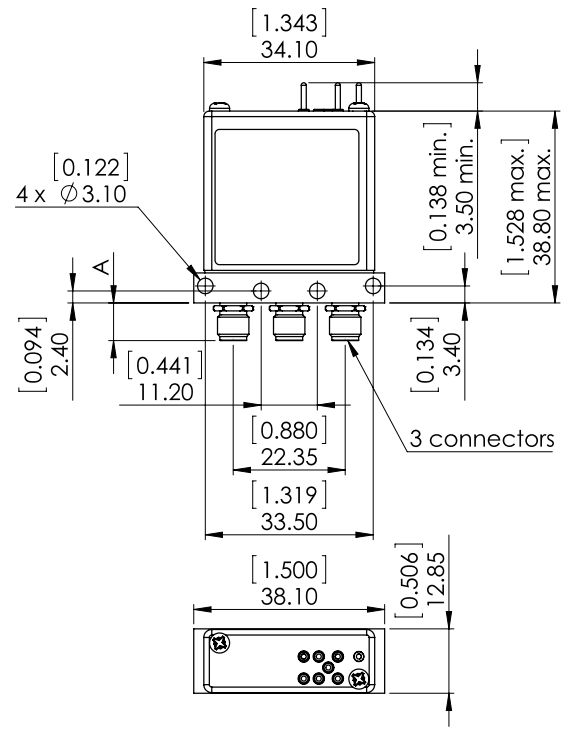
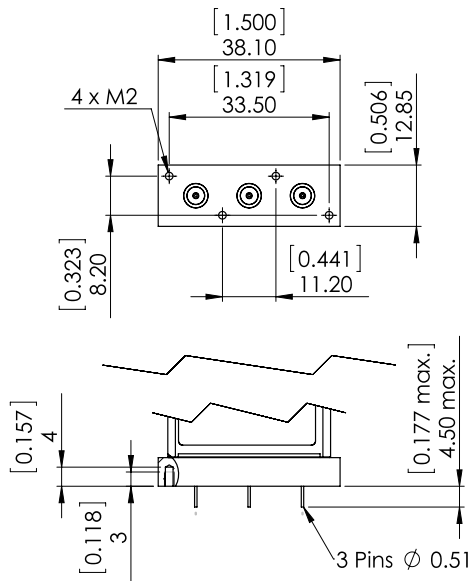

Notes

See page 2-23 for pin identification.  
All dimensions are in millimeters [inches].

## ACCESSORIES

A printed circuit board interface connector (ordered separately) has been designed for easy mounting on terminals. For SPDT model R570 series = Radiall part number: R599 910 000.

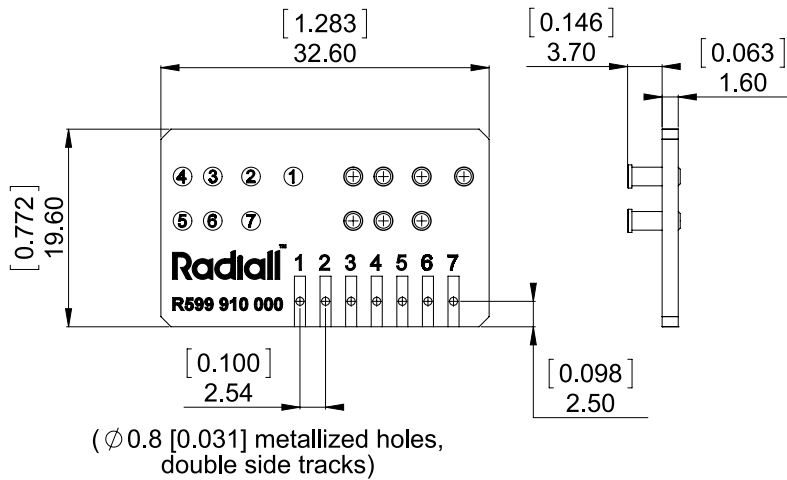

## Notes

All dimensions are in millimeters [inches].

The PCB accessory pin number assignment is independent from the pin identification table of the switch.

## SPDT UP TO 18 GHz

### N - TNC - BNC



Radiall's RAMSES SPDT N, BNC and TNC switches are designed for high performance in RF & Microwave systems up to 18 GHz.

Radiall's RAMSES concept (modular concept) offers a full range of configurations. They are commonly used for applications where high power handling capability is required.

These switches are dedicated to all market applications including: defense, instrumentation and telecommunications.

*Example of P/N: R570113035 is a SPDT N 12.4 GHz, failsafe, 28 Vdc, with suppression diodes, without option, D-Sub connector.*

### PART NUMBER SELECTION

# R570

**SERIES PREFIX** \_\_\_\_\_

**FREQUENCY RANGE** \_\_\_\_\_

- 0: N up to 3 GHz
- 1: N up to 12.4 GHz
- 2: BNC up to 3 GHz
- 5: TNC up to 3 GHz
- 6: TNC up to 12.4 GHz
- D: TNC up to 18 GHz

**TYPE** \_\_\_\_\_

- 1: Failsafe
- 2: Failsafe + I.C.
- 3: Latching
- 4: Latching + I.C.
- 5: Latching + S.C.O. <sup>[1]</sup>
- 6: Latching + S.C.O. + I.C. <sup>[1]</sup>

**ACTUATOR VOLTAGE** \_\_\_\_\_

- 2: 12 Vdc
- 3: 28 Vdc

**ACTUATOR TERMINALS**

- 0: Solder pins
- 5: D-Sub connector

**OPTIONS**

- 0: Without option
- 1: Positive common <sup>[2 & 3]</sup>
- 3: With suppression diodes <sup>[1]</sup>
- 4: With suppression diodes and positive common <sup>[1, 2 & 3]</sup>

**TTL OPTION**

- 0: Without TTL driver
- 1: With TTL driver <sup>[1 & 2]</sup>

**Notes**

- 1.C.: Indicator contact - S.C.O.: Self Cut-Off.
- 1. Suppression diodes are already included in Self Cut-Off and TTL option.
- 2. Polarity is not relevant to application for switches with TTL driver.
- 3. Positive common shall be specified only with type 3, 4, 5 and 6 because failsafe switches can be used with both polarities.

## RAMSES Series

## GENERAL SPECIFICATION

OPERATING MODE		FAILSAFE		LATCHING	
Nominal operating voltage (across temperature range)	Vdc	12	28	12	28
		(10.2 to 13)	(24 to 30)	(10.2 to 13)	(24 to 30)
Coil resistance at 23 °C (+/-10%)	Ω	38	200	38	225
Operating current at 23 °C	mA	320	140	320	125
Average power		See Power Rating Chart page 1-13			
TTL input	High level	2.2 to 5.5 Volts / 800 µA max 5.5 Volts			
	Low level	0 to 0.8 Volts / 20 µA max 0.8 Volts			
Indicator rating	ms	1 W/30 V/100 mA			
Switching time	ms	10			
Life		2.5 million cycles			
Connectors		N - TNC - BNC			
Actuator terminals		Solders pins or 9 pin D-Sub connector			
Operating temperature range		-40 °C to +85 °C			
Storage temperature range		-55 °C to +85 °C			
Vibration (MIL STD 202, Method 204D, cond.D)		10 - 2,000 Hz, 20 g		Operating	
Shock (MIL STD 202, Method 213B, cond.C)		100 g, 6 ms, ½ sine		Non-operating	

## RF PERFORMANCE

CONNECTORS	FREQUENCY RANGE GHz	V.S.W.R. (MAX)	INSERTION LOSS (MAX) dB	ISOLATION (MIN) dB	IMPEDANCE Ω	
N/TNC	DC - 3 DC - 12.4	DC - 1	1.15	0.15	85	50
		1-2	1.20	0.20	80	
		2 - 3	1.25	0.25	75	
		3 - 8	1.35	0.35	70	
		8 - 12.4	1.50	0.50	60	
TNC 18	DC - 18	DC - 6	1.30	0.30	70	
		6 - 12.4	1.50	0.50	60	
		12.4 - 18	1.60	0.70	60	
BNC	DC - 3	DC - 1	1.15	0.15	85	
		1 - 2	1.20	0.20	80	
		2-3	1.25	0.25	75	

## Notes

See page 2-18 for typical RF performance.

**R570 TYPICAL RF PERFORMANCE**

*Example: SPDT N and TNC up to 12.4 GHz*

**INSERTION LOSS & ISOLATION**

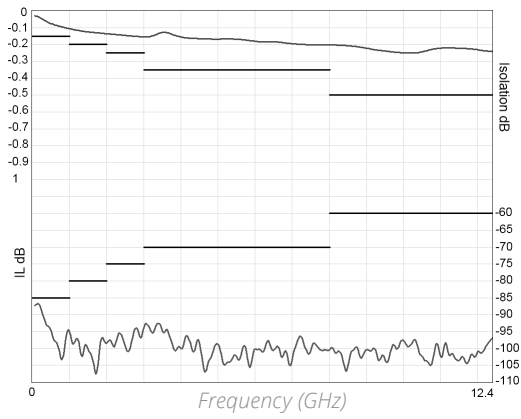

**V.S.W.R**

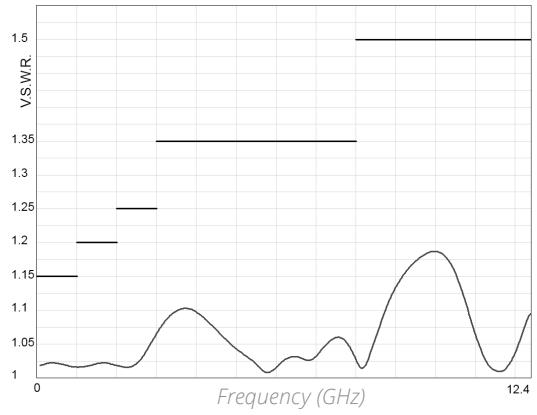

*Example: SPDT TNC up to 18 GHz*

**INSERTION LOSS & ISOLATION**

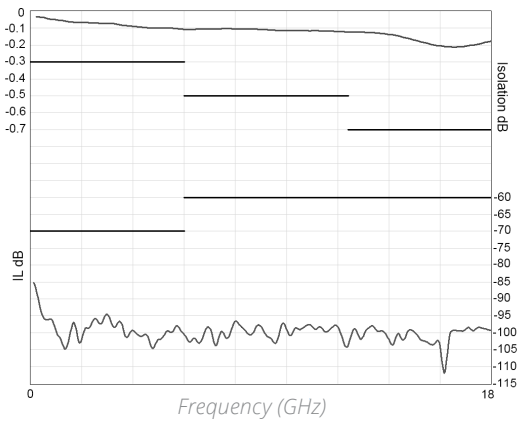

**V.S.W.R**

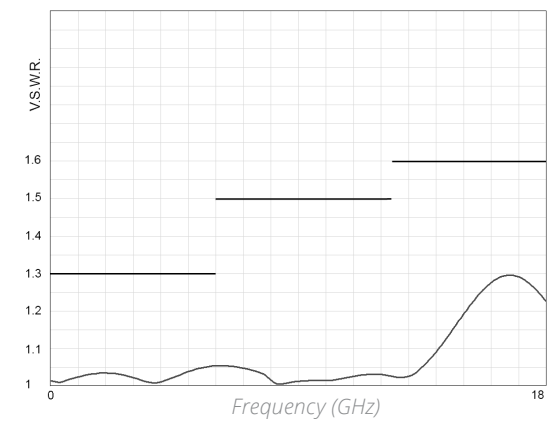

RAMSES Series

TYPICAL OUTLINE DRAWING

WITH SOLDER PINS

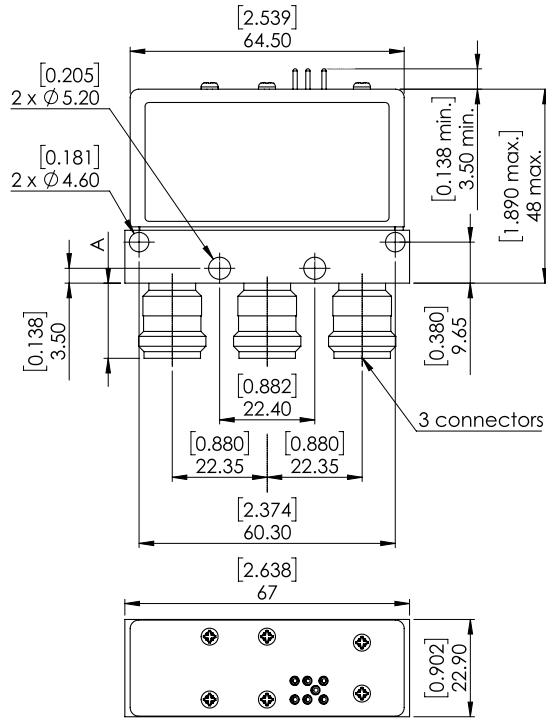

WITH D-SUB CONNECTOR

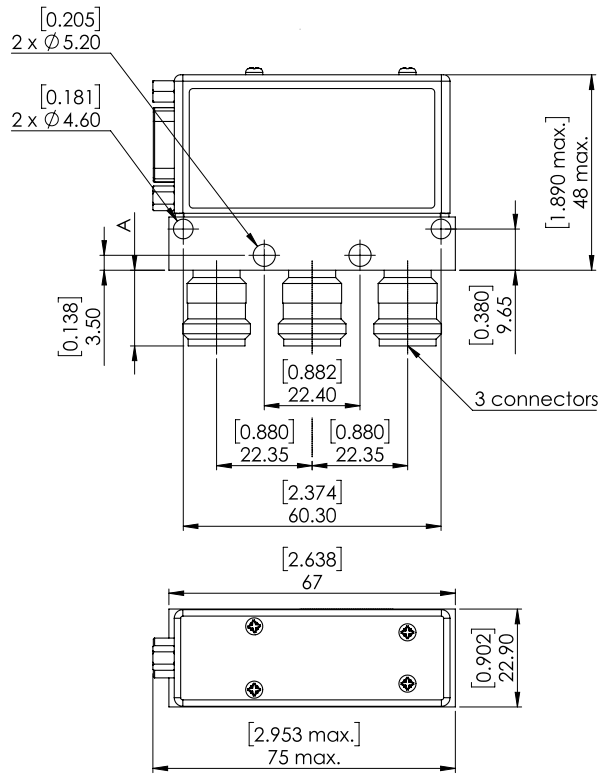

CONNECTORS	N	TNC	BNC
A max (mm [inches])	18.5 [0.709]	11.5 [0.433]	11.5 [0.433]

ACCESSORIES

A printed circuit board interface connector (ordered separately) has been designed for easy mounting on terminals. For SPDT model R570 series = Radiall part number: R599 910 000

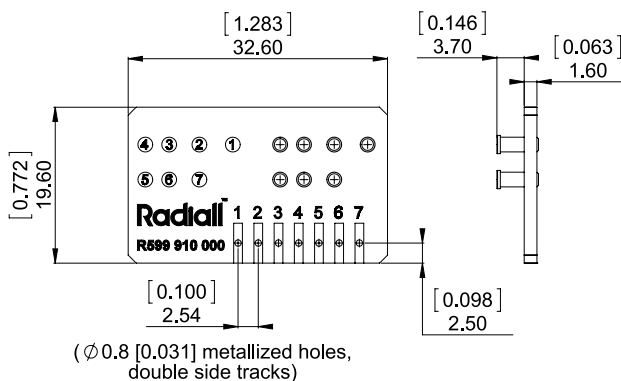

Notes

All dimensions are in millimeters [inches].

The PCB accessory pin number assignment is independant from the pin identification table of the switch.

## COAXIAL SPDT

### R570 SERIES

#### FAILSAFE

WITHOUT OPTION  
R570-1-000

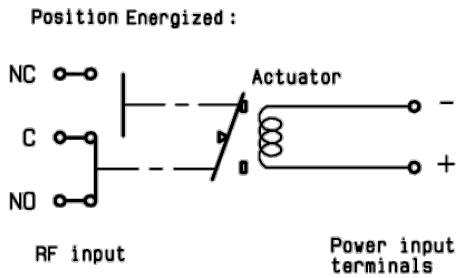

WITH INDICATOR CONTACT  
R570-2-000

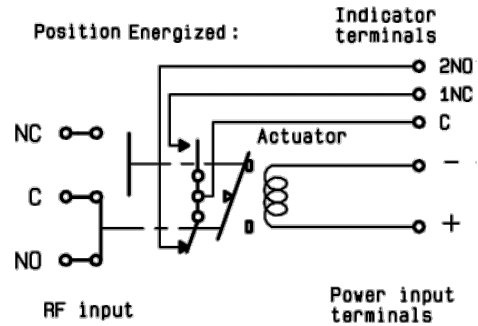

WITH SUPPRESSION DIODES  
R570-1-030

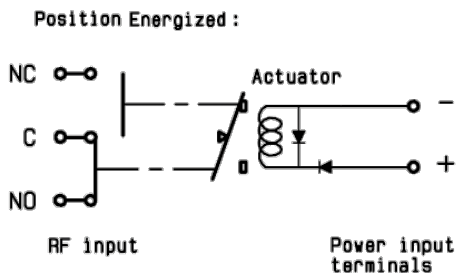

WITH SUPPRESSION DIODES & INDICATOR CONTACT  
R570-2-030

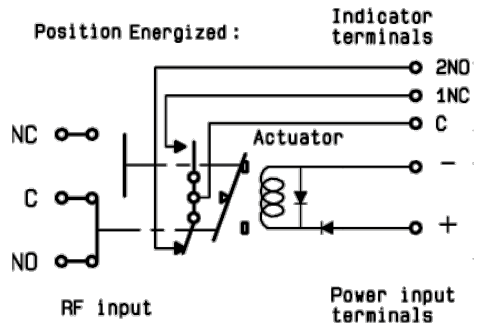

WITH TTL DRIVER (SUPPRESSION DIODES ARE INCLUDED)  
R570-1-100

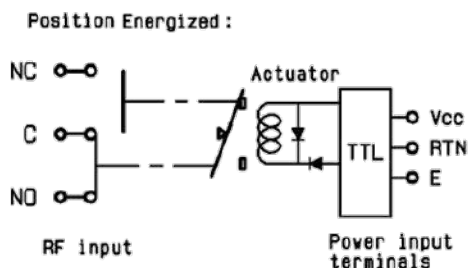

WITH TTL DRIVER & INDICATOR CONTACT  
(SUPPRESSION DIODES ARE INCLUDED)  
R570-2-100

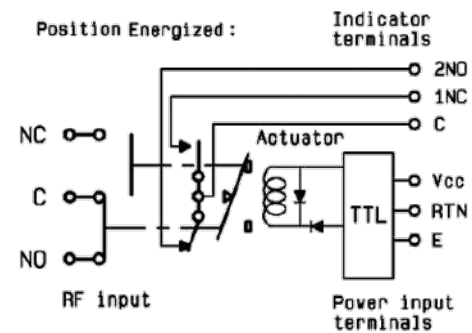



## COAXIAL SPDT

### R570 SERIES

#### LATCHING

WITHOUT OPTION  
R570-3-000

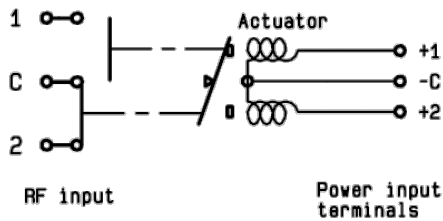

WITH INDICATOR CONTACT  
R570-4-000

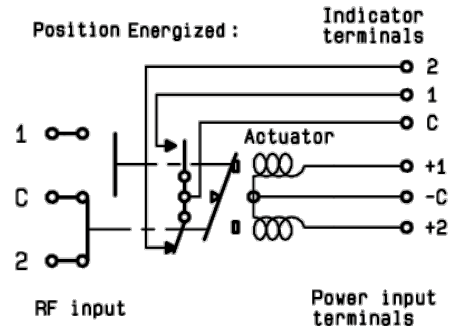

WITH SUPPRESSION DIODES  
R570-3-030

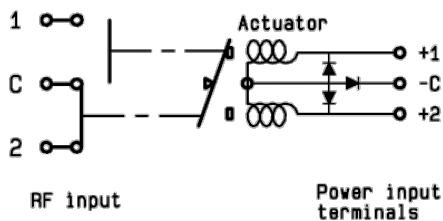

WITH SUPPRESSION DIODES & INDICATOR CONTACT  
R570-4-030

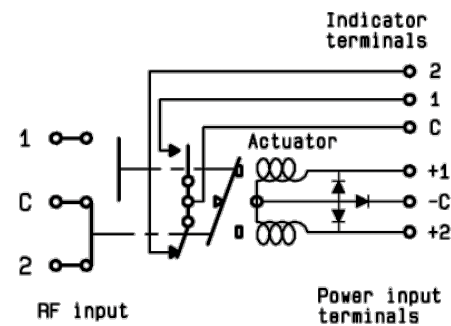

WITH TTL DRIVER (SUPPRESSION DIODES ARE INCLUDED)  
R570-3-100

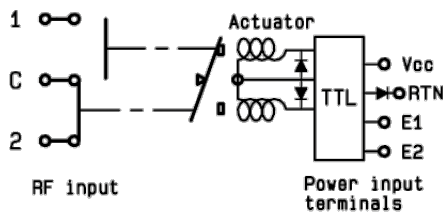

WITH TTL DRIVER & INDICATOR CONTACT  
(SUPPRESSION DIODES ARE INCLUDED)  
R570-4-100

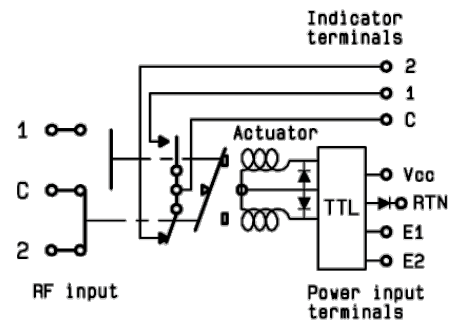

## COAXIAL SPDT (CONTINUED)

### R570 SERIES

#### LATCHING

WITH CUT-OFF (SUPPRESSION DIODES ARE INCLUDED)  
R570-5-100

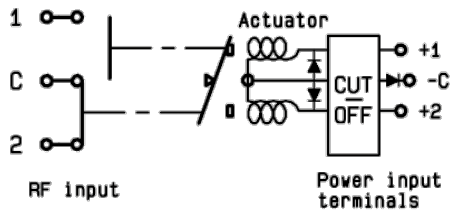

WITH CUT-OFF & INDICATOR CONTACT  
(SUPPRESSION DIODES ARE INCLUDED)  
R570-6-100

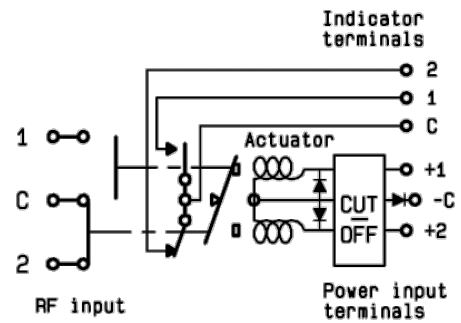

WITH CUT-OFF & TTL DRIVER  
(SUPPRESSION DIODES ARE INCLUDED)  
R570-5-100

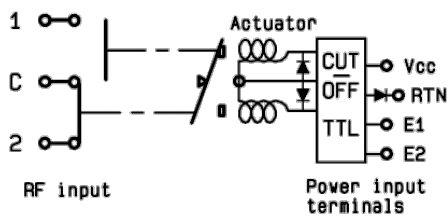

WITH CUT-OFF & INDICATOR CONTACT  
(SUPPRESSION DIODES ARE INCLUDED)  
R570-6-100

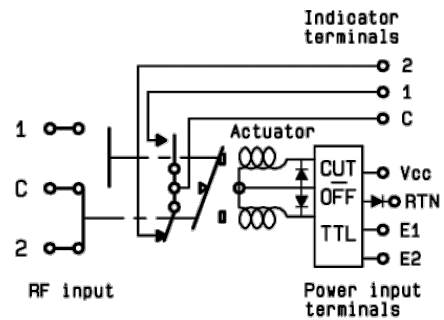

WITH POSITIVE COMMON, NO OPTION  
R570-3-010

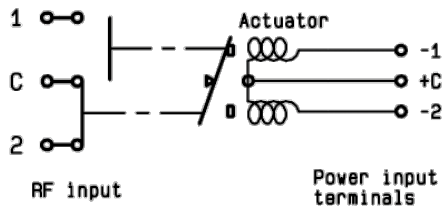

WITH POSITIVE COMMON & INDICATOR CONTACT  
R570-5-010

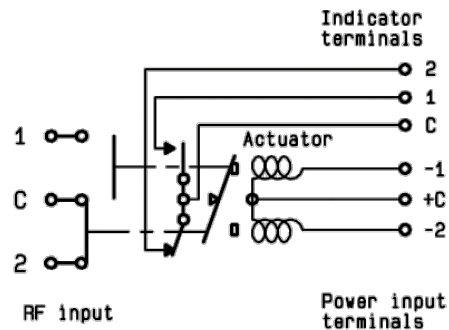

## COAXIAL SPDT (CONTINUED)

### R570 SERIES

#### LATCHING

WITH POSITIVE COMMON & SUPPRESSION DIODES  
R570-3-040

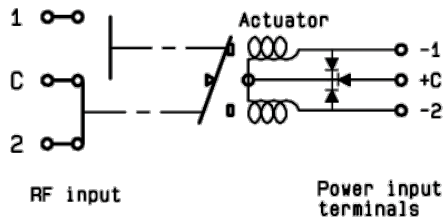

WITH POSITIVE COMMON, SUPPRESSION  
(DIODES & INDICATOR CONTACT)  
R570-4-040

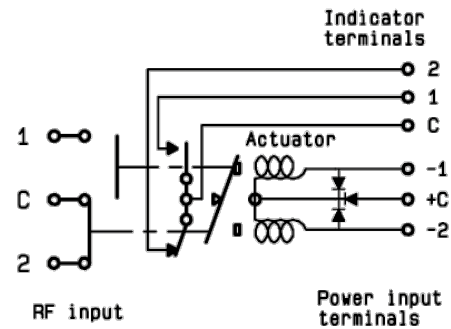

WITH POSITIVE CUT-OFF (SUPPRESSION DIODES ARE INCLUDED)  
R570-5-010

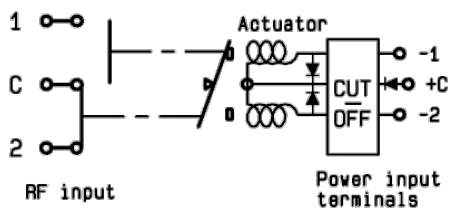

WITH POSITIVE COMMON, CUT-OFF & INDICATOR CONTACT  
(SUPPRESSION DIODES ARE INCLUDED)  
R570-6-010

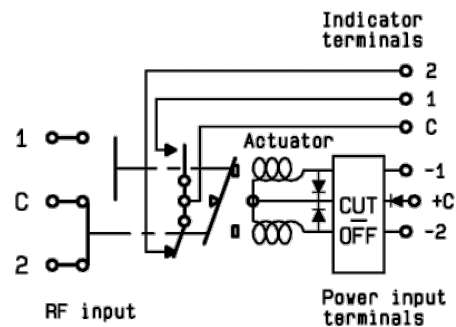

#### PIN IDENTIFICATION

TYPE	PIN						
	1	2	3	4	6	7	8
Failsafe	+		-				
Failsafe + I.C.	+		-		2NO	1NC	C
Failsafe + TTL	E		RTN	VCC			
Failsafe + I.C. + TTL	E		RTN	VCC	2NO	1NC	C
Latching Latching + Cut-off	-2 or +2	-1 or +1	+C or -C				
Latching + I.C. Latching + I.C. + Cut-off	-2 or +2	-1 or +1	+C or -C		2	1	C
Latching + TTL Latching + TTL + Cut-off	E2	E1	RTN	VCC			
Latching + TTL + I.C. Latching + TTL + I.C. + Cut-off	E2	E1	RTN	VCC	2	1	C

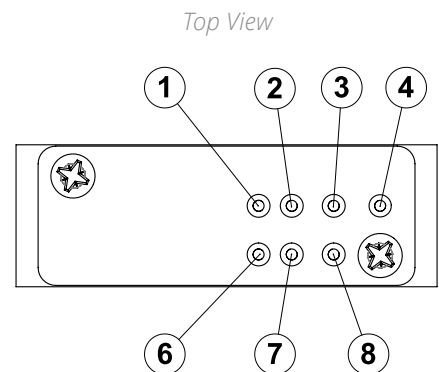

## HIGH PERFORMANCE SPDT UP TO 40 GHz

### SMA - SMA 2.9



Radiall's PLATINUM series switches are optimized to perform at a high level over an extended life cycle, with outstanding RF performance, and a guaranteed insertion loss repeatability of 0.03 dB over a life span of 10 million switching cycles. PLATINUM series switches are perfect for automated test and measurement equipment, as well as signal monitoring devices.

*Example of P/N: R595443125 is a SPDT SMA 20 GHz, latching, 24 Vdc, with TTL driver, Indicators, D-Sub connector.*

### PART NUMBER SELECTION

**R595**

**SERIES PREFIX** \_\_\_\_\_

**FREQUENCY RANGE** \_\_\_\_\_

- 3:** SMA up to 6 GHz
- 4:** SMA up to 20 GHz
- F:** SMA up to 26.5 GHz
- 8:** SMA 2.9 up to 40 GHz

**TYPE** \_\_\_\_\_

- 3:** Latching <sup>[1]</sup>
- 4:** Latching + I.C. <sup>[1]</sup>
- 5:** Latching + S.C.O. <sup>[1]</sup>
- 6:** Latching + S.C.O. + I.C. <sup>[1]</sup>

**ACTUATOR VOLTAGE** \_\_\_\_\_

- 3:** 24 Vdc
- 7:** 15 Vdc

**SWITCH MODEL** \_\_\_\_\_

- 1:** Non-terminated SPDT switch

**OPTIONS**

- 1:** Without option (positive common)
- 2:** Compatible TTL driver

**ACTUATOR TERMINALS** \_\_\_\_\_

- 0:** Solder pins
- 5:** D-Sub connector

**DOCUMENTATION** \_\_\_\_\_

- :** Certificate of conformity
- C:** Calibration certificate
- R:** Calibration certificate + RF curves

**Notes**

- I.C.:* Indicator contact - *S.C.O.:* Self Cut-Off
- 1.* Suppression diodes are already included

## Platinum Series

## GENERAL SPECIFICATIONS

OPERATING MODE		LATCHING	
Nominal operating voltage (across temperature range)	Vdc	24 (24 to 30)	15 (12 to 20)
Coil resistance at 23 °C (+/-10%)	Ω	350	120
Operating current at 23 °C	mA	68	125
TTL input	High level	3 to 7 Volts: 800 µA max 7 Volts	
	Low level	0 to 0.8 Volts: 20 µA max 0.8 Volts	
Switching time	ms	15	
Life (Min)	SMA	10 million cycles	
	SMA 2.9	5 million cycles	
Actuator terminals		D-Sub 9 pin female Solder pins	
Weight	g	60	

## ENVIRONMENTAL SPECIFICATIONS

Operating temperature range	-25 °C to + 75 °C
Storage temperature range	-55 °C to +85 °C
Temperature cycling (MIL STD 202F, Method 107D, Cond.A)	-55 °C to +85 °C (10 cycles)
Sine vibration operating (MIL STD 202, Method 204D, Cond.D)	10 - 2,000 Hz, 20 g
Random vibration operating	16.91 g (rms) 50-2,000 Hz 3 min/axis
Shock operating (MIL STD 202, Method 213B, Cond.G)	50 g / 11 ms, sawtooth
Humidity operating	15 to 95% relative humidity
Humidity storage (MIL STD 202, Method 106E, Cond.E)	65 °C, 95% RH, 10 days
Altitude operating	15 ft (4.600 meters)
Altitude storage (MIL STD 202, Method 105C, Cond.B)	50 ft (15.240 meters)

Platinum Series

RF PERFORMANCE

PART NUMBER		R5953--1--	R5954--1--		R595F--1--		R5958--1--		
Frequency range	GHz	DC to 6	DC to 20		DC to 26.5		DC to 40		
Impedance	Ω	50							
Insertion Loss (max)	dB	0.20 + (0.45 / 26.5) × frequency (GHz)							
Isolation (min)	dB	85	DC to 6 GHz 6 to 12.4 GHz 12.4 to 20 GHz	85 75 65	DC to 6 GHz 6 to 12.4 GHz 12.4 to 20 GHz 20 to 26.5 GHz	85 75 65 60	DC to 6 GHz 6 to 12.4 GHz 12.4 to 20 GHz 20 to 26.5 GHz 26.5 to 40 GHz	85 75 65 60 55	
V.S.W.R (max)		1.15	DC to 6 GHz 6 to 12.4 GHz 12.4 to 20 GHz	1.15 1.25 1.30	DC to 6 GHz 6 to 12.4 GHz 12.4 to 20 GHz 20 to 26.5 GHz	1.15 1.25 1.30 1.60	DC to 6 GHz 6 to 12.4 GHz 12.4 to 20 GHz 20 to 26.5 GHz 26.5 to 40 GHz	1.15 1.25 1.30 1.60 1.80	
Repeatability (up to 10 million cycles at 25 °C)	dB	0.03 dB maximum					0.05 dB maximum		

TYPICAL RF PERFORMANCE

INSERTION LOSS & ISOLATION

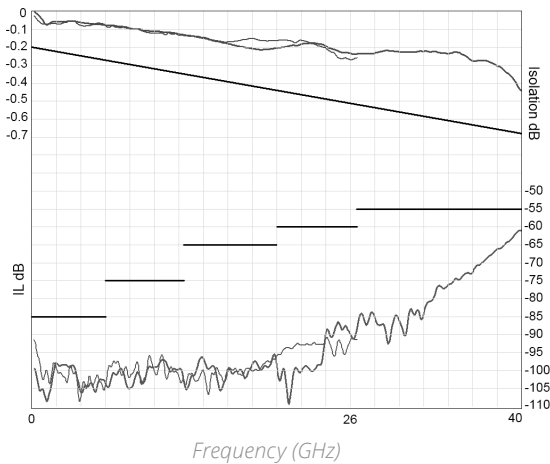

V.S.W.R

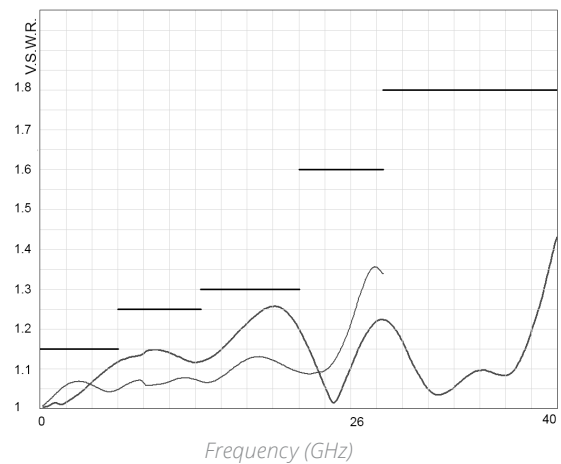

SMA — SMA 2.9 —

**SWITCH MODEL: NON-TERMINATED SPDT SWITCH**

The non-terminated SPDT switch is a single pole double throw switch. This switch is considered "break-before-make."

*RF Schematic Diagram*

**POSITION E1**

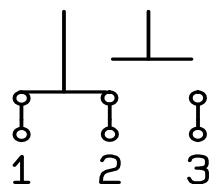

**POSITION E2**

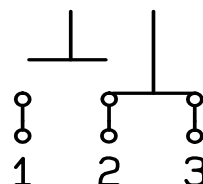

*Position Indicator*

**STATE 11**

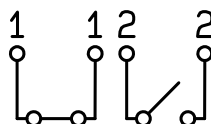

**STATE 22**

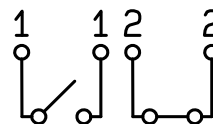

**Standard drive option "1"**

(Positive common):

- Connect pin +Vcc to supply (+20 Vdc to +32 Vdc)
- Select desired RF path by applying ground to the corresponding "close" pin (Ex: ground pin E1 to switch to position E1. RF path 1-2 closed and RF path 2-3 open)
- To open desired path and close the new RF path, connect ground to the corresponding "close" pin (Ex: ground pin E2 to open RF path 1-2 and close RF path 2-3)

**TTL drive option "2"**

- Connect pin GND to ground
- Connect pin +Vcc to supply (+20 Vdc to +32 Vdc)
- Select (close) desired RF path by applying TTL "High" to the corresponding "drive" pin (Ex: apply TTL "High" to pin E1 to switch to position E1. RF path 1-2 closed and RF path 2-3 open)
- To open desired path and close the new RF path, apply TTL "High" to the "drive" pin which corresponds to the desired RF path (Ex: apply TTL "High" to pin E2)

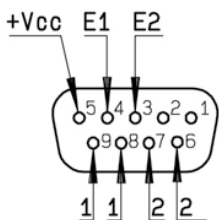

D-Sub connector

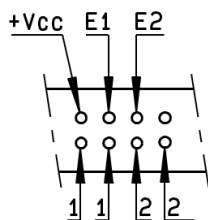

Solder pins

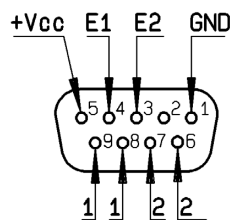

D-Sub connector

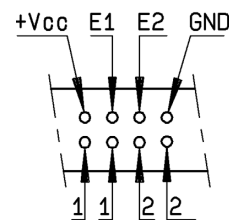

Solder pins

**SMA - SMA 2.9**  
TYPICAL OUTLINE DRAWING

**WITH D-SUB CONNECTOR**

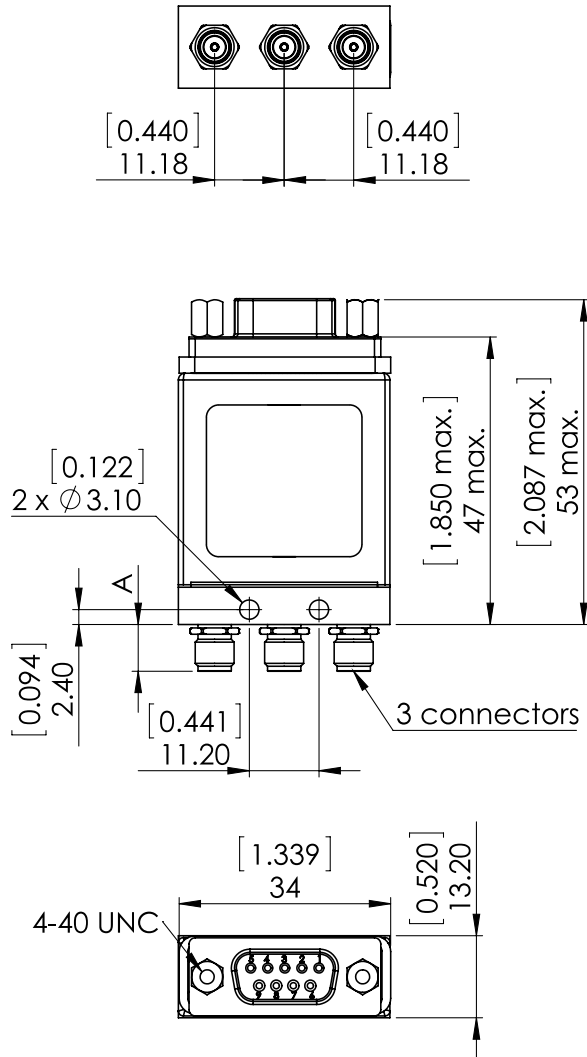

**WITH SOLDER PINS**

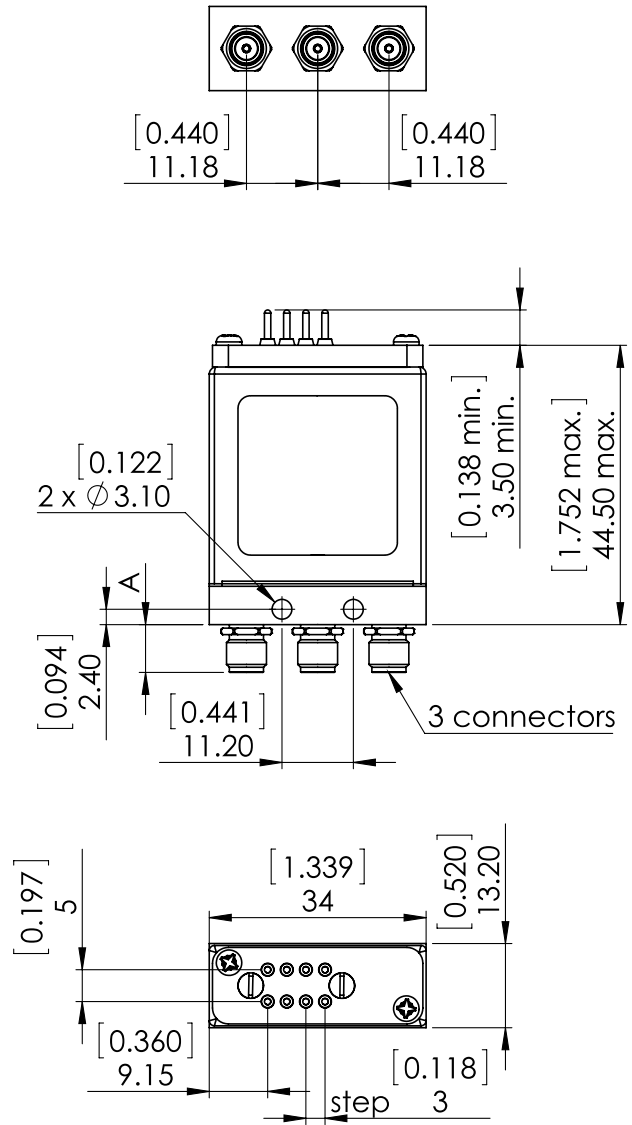

CONNECTORS	A MAX MM [INCHES]
SMA	7.7 [0.303]
SMA 2.9	6.7 [0.264]

**Notes**

All dimensions are in millimeters [inches].



### RF POWER RATING CHART

This graph is based on the following conditions:

- Ambient temperature: + 25 °C
- Sea level
- V.S.W.R.: 1 and cold switching

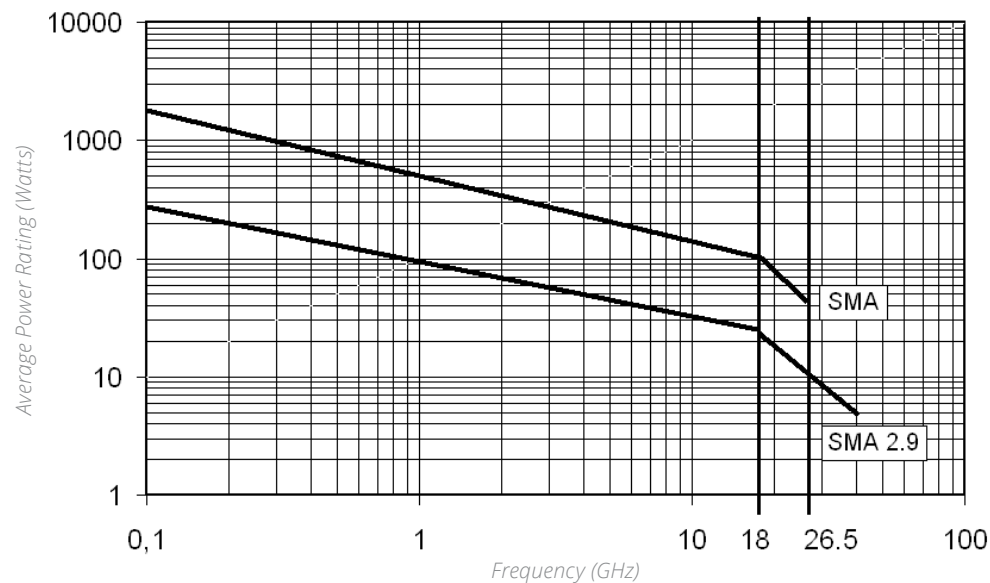

### DERATING FACTOR VERSUS VSWR

The average power input must be reduced for load V.S.W.R. above 1:1

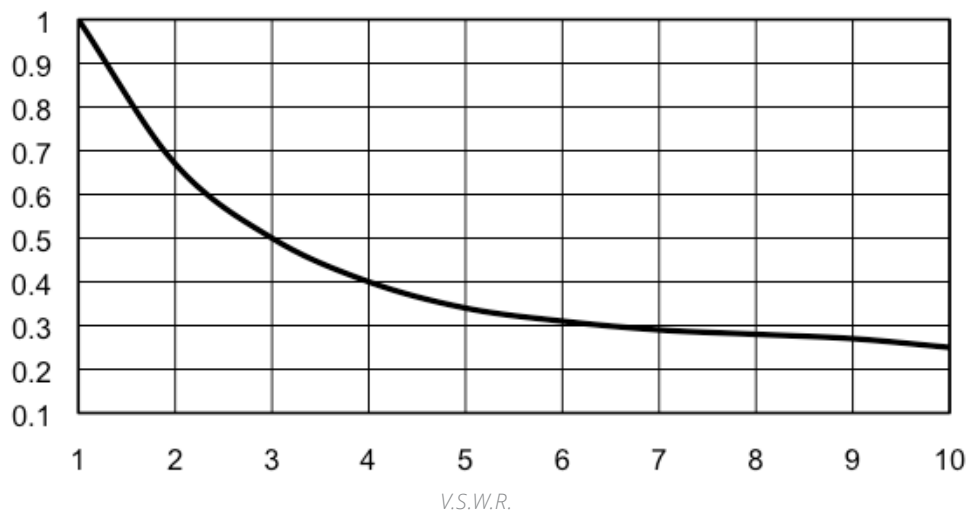

Optional Features

**OPTIONAL FEATURES**  
**GENERAL**



All miniature SPDT switches fitted with SMA, QMA, 2.4 mm or SMA 2.9 connectors can be delivered with 34 mm narrow width RF body.

Contact Radiall sales directly for availability.

EXAMPLES OF DEDICATED APPLICATION OPTIONS



SMA SPDT with a SINGLE input TTL driver. This option is available in a latching configuration upon special request. Key advantages include less wires and easier connection.



SPDT with MILC38999 circular connector for L band airborne applications.



SPDT models available for high power military applications (up to 100 watts CW from DC to 18 GHz).

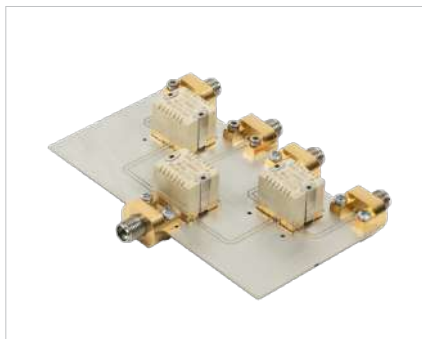

A SP4T design up to 26.5 GHz with SMT relays mounted on a PCB fitted with UMP (Ultra Miniature Pressure) contact. Various switching configurations can be designed according to your specific requests.



SPDT with D-sub connector can be designed.



## DP3T & SPDT TERMINATED

---



Section 3 Table of Contents

**RAMSES SERIES**

DP3T and Terminated SPDT up to 50 GHz: R585 Series ..... 3-2 to 3-7

**ELECTRICAL SCHEMATICS**

Coaxial DP3T and Terminated SPDT: R585 Series ..... 3-8 to 3-13

**PLATINUM SERIES**

High performance DP3T and Terminated SPDT up to 40 GHz: R595 Series ..... 3-14 to 3-23

**OPTIONAL FEATURES**

Optional Features for DP3T Switches..... 3-24

**DP3T PART NUMBER SELECTION GUIDE<sup>[1]</sup>**

		DIGITAL POSITION	
		R 1-3:	
		4: RF CONNECTORS	
		5: TYPE	
		6: VOLTAGE	
		7: SWITCH MODEL	
		8: OPTIONS	
		9: TERMINALS	
		10: DOCUMENTATION	
PLATINUM	RAMSES	Series Configuration	
DP3T	DP3T	-	
R595	R585	-	
-	3	SMA 3 GHz	
3	-	SMA 6 GHz	
-	4	SMA 18 GHz	
4	-	SMA 20 GHz	
F	F	SMA 26.5 GHz	
8	8	SMA 2.9 40 GHz	
-	J	2.4 mm 50 GHz	
-	1	Failsafe	
3	3	Latching	
-	7	Normally open	
-	2	12V	
7	-	15V	
3	-	24V	
-	3	28V	
5	0/1	DP3T	
2	2/3/4/5	SPDT Terminated	
3	6/7	Terminated 4 ports Bypass	
0	0	Without option	
1	1	Positive common	
-	3	Supression diodes	
-	4	Positive common and suppression diodes	
0	0	Solder pins	
5	-	D-Sub connector	
-	-	Certificate of conformity	
C	-	Calibration certificate	
R	-	Calibration certificate + RF curves	

**Notes**

TTL driver is already included for the 1, 3, 5 and 7 switch models of the RAMSES R585 series.

Example of P/N: R585832000 is a DP3T SMA2.9 40 GHz, latching, 12 Vdc, without option, solder pins.

1. For part number creation and available options, see detailed part number selection for each series.

RAMSES Series

**DP3T & TERMINATED SPDT UP TO 50 GHz**  
**SMA - SMA 2.9 - 2.4 MM**



Radiall’s RAMSES DP3T and Terminated SPDT switches offer excellent reliability, high performance and operating frequencies from DC to 50 GHz. A full range of options are available within the RAMSES range in order to offer customers a complete solution.

These relays are dedicated to market applications including: defense, instrumentation and telecommunication.

*Example of P/N: R585423300 is a SPDT terminated SMA 18 GHz, failsafe, 28 Vdc, indicator contacts, internal terminations without TTL drivers and solder pins.*

**PART NUMBER SELECTION**

**R585**

**SERIES PREFIX**

**RF CONNECTORS**

- 3: SMA up to 3 GHz
- 4: SMA up to 18 GHz
- F: SMA up to 26.5 GHz
- 8: SMA 2.9 up to 40 GHz <sup>[5]</sup>
- J: 2.4 mm up to 50 GHz <sup>[4]</sup>

**TYPE**

- 1: Failsafe
- 2: Failsafe + I.C.
- 3: Latching
- 4: Latching + I.C.
- 5: Latching + S.C.O. <sup>[1]</sup>
- 6: Latching + S.C.O. + I.C. <sup>[1]</sup>
- 7: Normally open
- 8: Normally open + I.C.

**ACTUATOR VOLTAGE**

- 2: 12 Vdc
- 3: 28 Vdc

**ACTUATOR TERMINALS**

- 0: Solder pins

**OPTIONS**

- 0: Without option
- 1: Positive common <sup>[2 & 3]</sup>
- 3: With suppression diodes <sup>[1]</sup>
- 4: With suppression diodes and positive common <sup>[1, 2 & 3]</sup>

**SWITCH MODEL**

- 0: Non-terminated 5 port DP3T switch without TTL driver
- 1: Non-terminated 5 port DP3T switch with TTL driver <sup>[1 & 2]</sup>
- 2: Terminated SPDT switch without TTL driver / internal termination
- 3: Terminated SPDT switch with TTL driver / internal termination <sup>[1 & 2]</sup>
- 4: Terminated SPDT switch without TTL driver / external termination
- 5: Terminated SPDT switch with TTL driver / external termination <sup>[1 & 2]</sup>
- 6: Terminated 4 port bypass switch without TTL driver / external termination
- 7: Terminated 4 port bypass switch with TTL driver / external termination <sup>[1 & 2]</sup>

**Notes**

- I.C.: Indicator contact/S.C.O.: Self Cut-Off
- 1. Suppression diodes are already included in Self Cut-Off and TTL option
- 2. Polarity is not relevant to application for switches with TTL driver
- 3. Positive common shall be specified only with type 3, 4, 5, 6, 7 and 8 because

- failsafe switches can be used with both polarities*
- 4. Not available with switch model "2" and "3"
- 5. Connector SMA 2.9 is equivalent to "K connector", registered trademark of Anritsu.

## RAMSES Series

## GENERAL SPECIFICATIONS

OPERATING MODE		FAILSAFE		LATCHING		NORMALLY OPEN	
Nominal operating voltage (across operating temperature)	Vdc	12	28	12	28	12	28
		(10.2 to13)	(24 to 30)	(10.2 to13)	(24 to 32)	(10.2 to13)	(24 to 32)
Coil resistance (+/-10%)	Ω	24	138	29	175	47.5	275
Nominal operating current at 23 °C	mA	500	205	420	160	250	102
Average power		See Power Rating Chart page 1-13					
		Internal terminations: 1 Watt CW into 50 Ohms					
TTL input	High level	2.2 to 5.5 Volts			800 μA max 5.5 Volts		
	Low level	0 to 0.8 Volts			20 μA max 5.5 Volts		
Indicator rating		1 W / 30 V / 100 mA					
Switching time (max)	ms	10					
Life (min)	SMA - SMA 2.9	2 million cycles for Normally open and internal terminated models 10 million cycles for all other products					
	2.4 mm	2 million cycles					
Actuator terminals		Solder pins					
Operating temperature range	SMA - SMA 2.9	-40 °C to +85 °C					
	2.4 mm	-25 °C to +70 °C					
Storage temperature range	SMA -SMA 2.9	-55 °C to +85 °C					
	2.4 mm	-40 °C to +85 °C					
Vibration (MIL STD 202, Method 204D, cond.D)		10-2,000 Hz, 20 g			Operating		
Shock (MIL STD 202, Method 213B, cond.C)		100 g / 6 ms, ½ sine			Operating		

## RF PERFORMANCE

CONNECTORS	FREQUENCY RANGE GHz	V.S.W.R. (MAX)	INSERTION LOSS (MAX) dB	ISOLATION (MIN) dB	IMPEDANCE Ω	
SMA	DC - 3 DC - 18 DC - 26.5	DC - 3	1.20	0.20	80	50
		3 - 8	1.30	0.30	70	
		8 - 12.4	1.40	0.40	60	
		12.4 - 18	1.50	0.50	60	
		18 - 26.5	1.70	0.70	55	
SMA 2.9	DC - 40	DC - 6	1.30	0.30	70	50
		6 - 12.4	1.40	0.40	60	
		12.4 - 18	1.50	0.50	60	
		18 - 26.5	1.70	0.70	55	
		26.5 - 40	1.90	0.80	50	
2.4 mm	DC - 50	DC - 6	1.30	0.30	70	50
		6 - 12.4	1.40	0.40	60	
		12.4 - 18	1.50	0.50	60	
		18 - 26.5	1.70	0.70	55	
		26.5 - 40	1.90	0.80	50	
		40 - 50	1.90	1.1	50	

## Notes

See page 3-4 for typical RF performance.

RAMSES Series

R585 TYPICAL RF PERFORMANCE

Example: DP3T SMA up to 26.5 GHz

INSERTION LOSS & ISOLATION

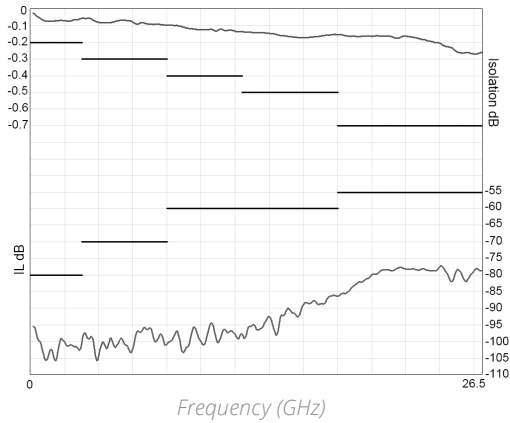

V.S.W.R

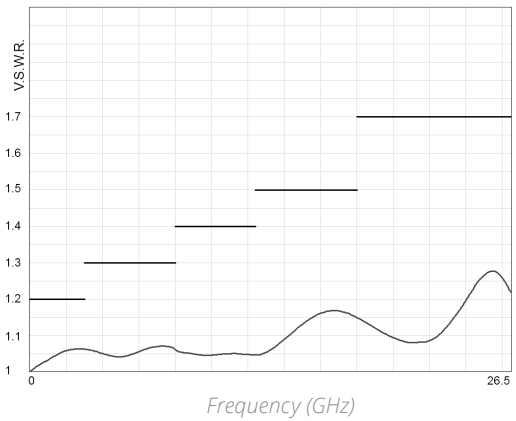

Example: DP3T SMA 2.9 up to 40 GHz

INSERTION LOSS & ISOLATION

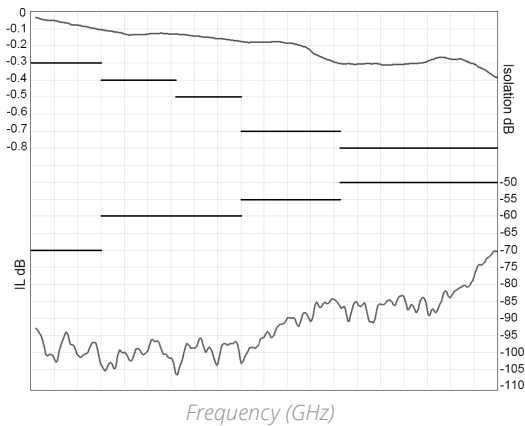

V.S.W.R

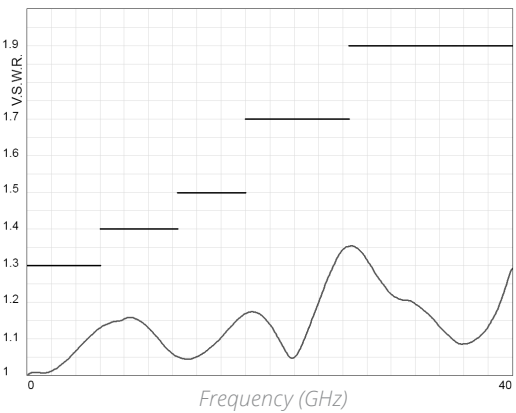

Example: DP3T 2.4 mm up to 50 GHz

INSERTION LOSS & ISOLATION

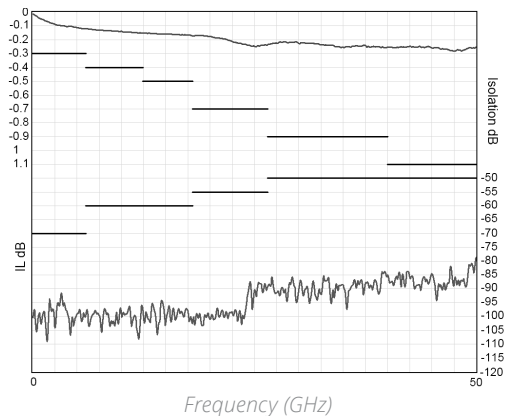

V.S.W.R

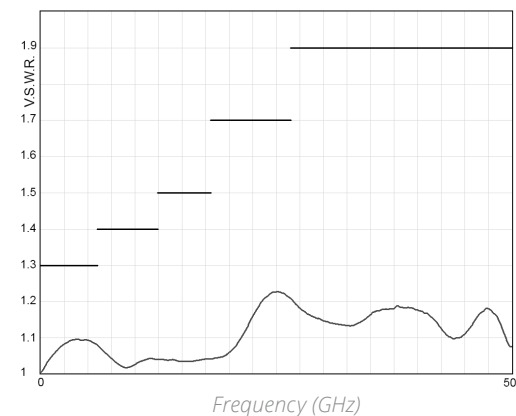



RAMSES Series

TYPICAL OUTLINE DRAWING

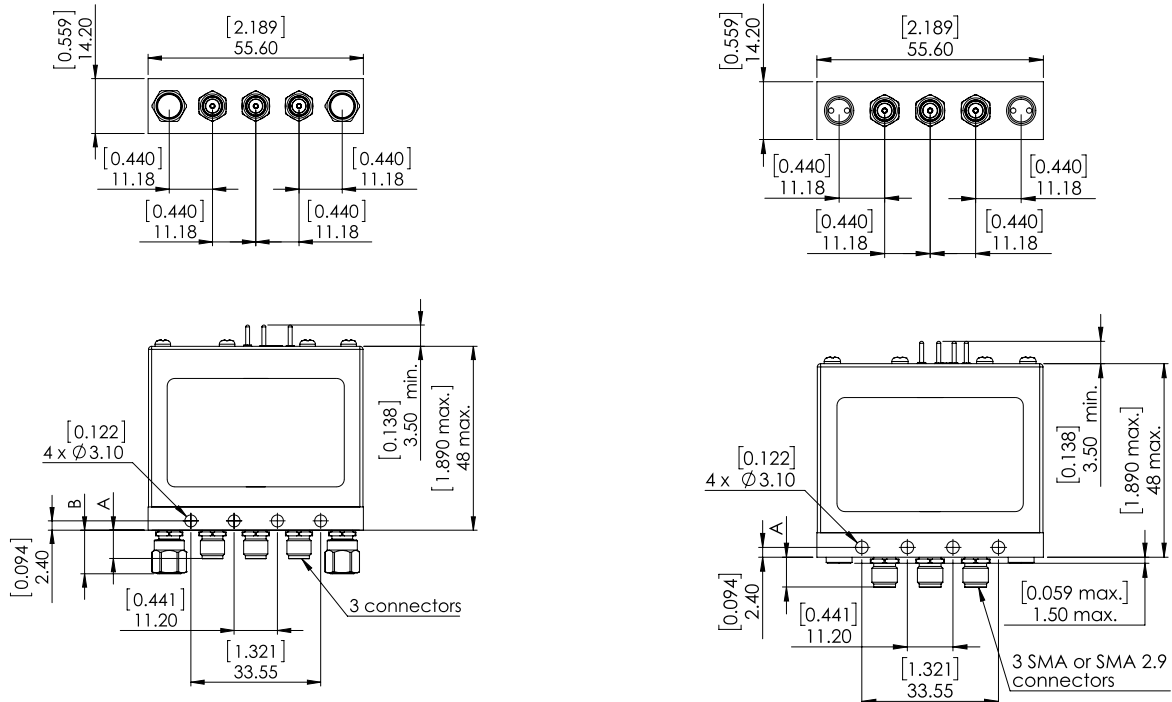

**TERMINATED SPDT SWITCH / EXTERNAL TERMINATIONS**  
**R585 --- 4--**  
**R585 --- 5--**

**TERMINATED SPDT SWITCH / INTERNAL TERMINATIONS**  
**R585 --- 2--**  
**R585 --- 3--**

CONNECTORS	A MAX (MM [INCHES])	B MAX (MM [INCHES]) IF APPLICABLE
SMA up to 18 GHz	7.7 [0.303]	13.5 [0.118]
SMA up to 26.5 GHz	7.7 [0.303]	21 [0.827]
SMA 2.9 up to 40 GHz	6.7 [0.264]	21 [0.827]
2.4 mm up to 50 GHz	6.7 [0.264]	21 [0.827]

**Notes**

All dimensions are in millimeters [inches].  
 See page 3-13 for pin identification.

RAMSES Series

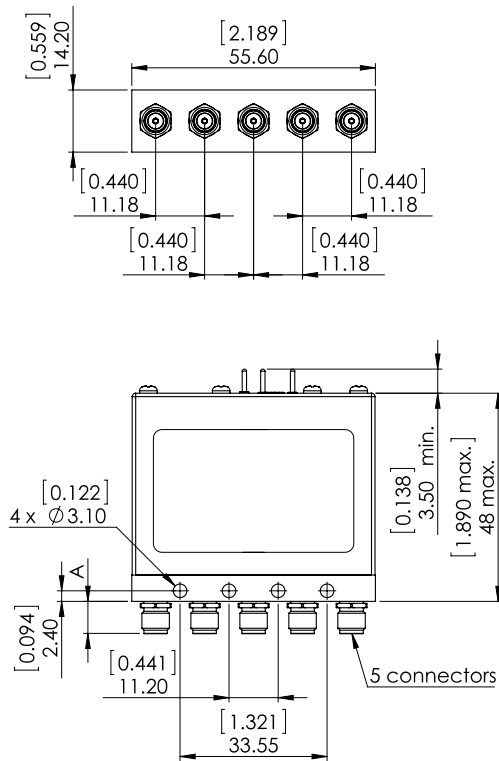

**NON-TERMINATED 5 PORT DP3T SWITCH**  
 R585 --- 0--  
 R585 --- 1--

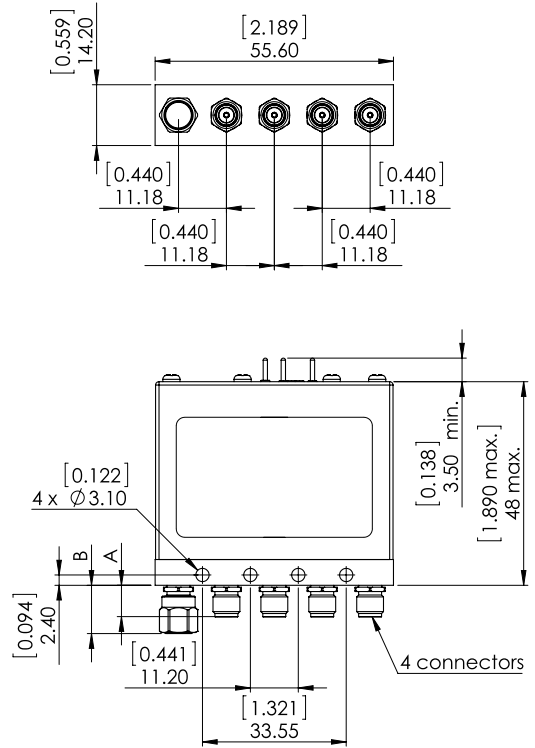

**TERMINATED 4 PORT BYPASS SWITCH/EXTERNAL TERMINATION**  
 R585 --- 6--  
 R585 --- 7--

CONNECTORS	A MAX (MM [INCHES])	B MAX (MM [INCHES]) IF APPLICABLE
SMA up to 18 GHz	7.7 [0.303]	13.5 [0.118]
SMA up to 26.5 GHz	7.7 [0.303]	21 [0.827]
SMA 2.9 up to 40 GHz	6.7 [0.264]	21 [0.827]
2.4 mm up to 50 GHz	6.7 [0.264]	21 [0.827]

**Notes**

All dimensions are in millimeters [inches].  
 See page 3-13 for pin identification.

RAMSES Series

**R585 SERIES****ACCESSORIES**

A printed circuit board interface connector (ordered separately) has been designed for easy mounting on terminals.  
For DP3T model R585 series = Radiall part number: R599910000.

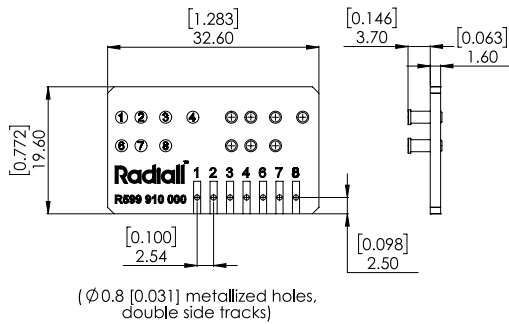
**Notes**

All dimensions are in millimeters [inches].

PCB accessory pin number assignment is independant from the pin identification table of the switch.

**COAXIAL DP3T & TERMINATED SPDT  
R585 SERIES  
FAILSAFE**

**WITHOUT OPTION**  
R585-1-000/R585-1-200/R585-1-400

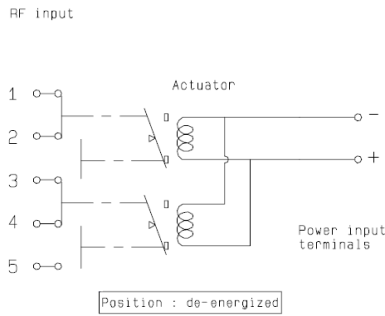

**WITH INDICATOR CONTACT**  
R585-2-000/R585-2-200/R585-2-400

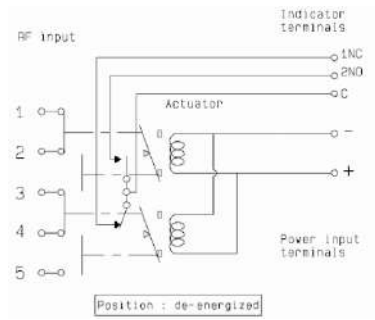

**WITH SUPPRESSION DIODES**  
R585-1-030/R585-1-230/R585-1-430

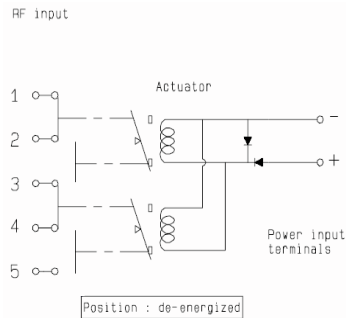

**WITH SUPPRESSION DIODES & INDICATOR CONTACT**  
R585-2-030/R585-2-230/R585-2-430

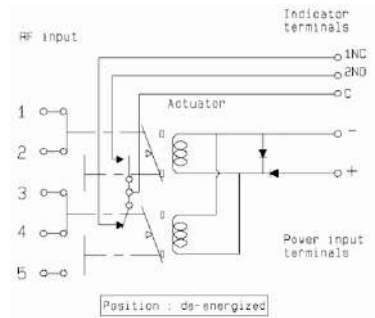

**WITH TTL DRIVER (SUPPRESSION DIODES ARE INCLUDED)**  
R585-1-100/R585-1-300/R585-1-500

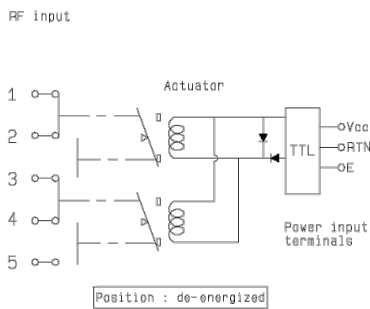

**WITH TTL DRIVER & INDICATOR CONTACT (SUPPRESSION DIODES ARE INCLUDED)**  
R585-2-100/R585-2-300/R585-2-500

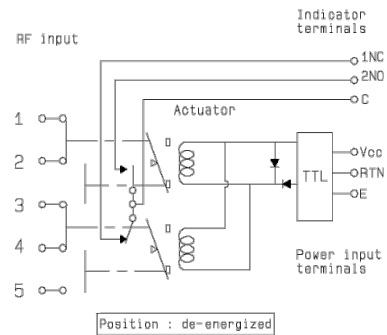

**COAXIAL DP3T & TERMINATED SPDT**  
**R585 SERIES**  
 NORMALLY OPEN

**WITHOUT OPTION**  
 R585-7-000/R585-7-200/R585-7-400

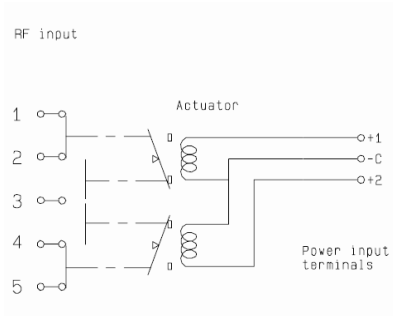

**WITH INDICATOR CONTACT**  
 R585-8-000/R585-8-200/R585-8-400

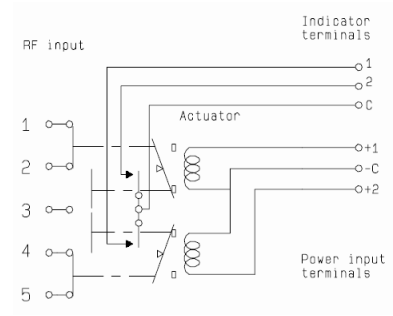

**WITH SUPPRESSION DIODES**  
 R585-7-030/R585-7-230/R585-7-430

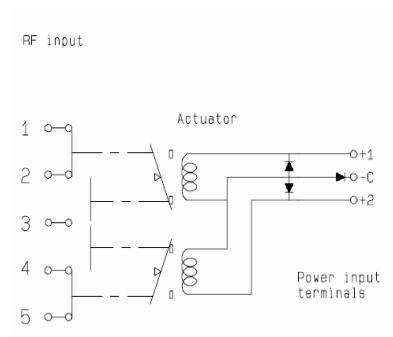

**WITH SUPPRESSION DIODES & INDICATOR CONTACT**  
 R585-8-030/R585-8-230/R585-8-430

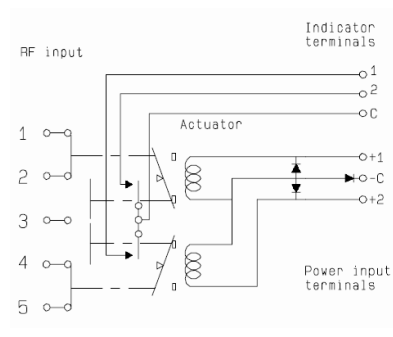

**WITH TTL DRIVER (SUPPRESSION DIODES ARE INCLUDED)**  
 R585-7-100/R585-7-300/R585-7-500

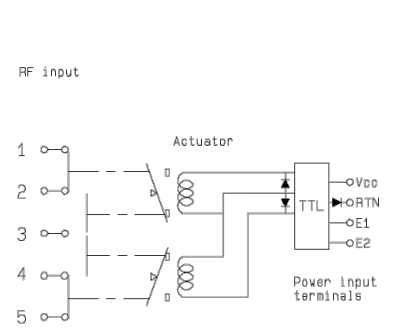

**WITH TTL DRIVER & INDICATOR CONTACT**  
 (SUPPRESSION DIODES ARE INCLUDED)  
 R585-8-100/R585-8-300/R585-8-500

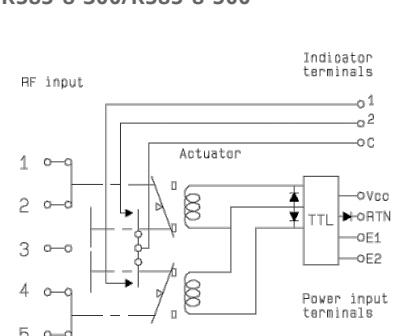

**COAXIAL DP3T & TERMINATED SPDT  
R585 SERIES**

NORMALLY OPEN & LATCHING

**WITH POSITIVE COMMON, NO OPTION**  
R585-7-010/R585-7-210/R585-7-410

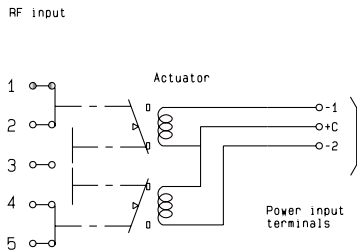

**WITH POSITIVE COMMON & INDICATOR CONTACT**  
R585-8-010/R585-8-210/R585-8-410

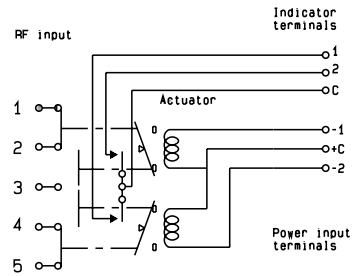

**WITH POSITIVE COMMON & SUPPRESSION DIODES**  
R585-7-040/R585-7-240/R585-7-440

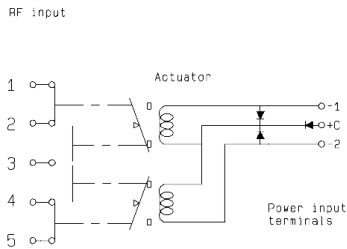

**WITH POSITIVE COMMON, INDICATOR CONTACT & SUPPRESSION DIODES**  
R585-8-040/R585-8-240/R585-8-440

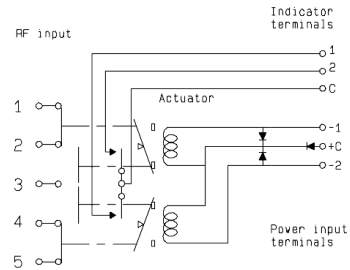

**WITHOUT OPTION**  
R585-3-000/R585-3-200/R585-3-400

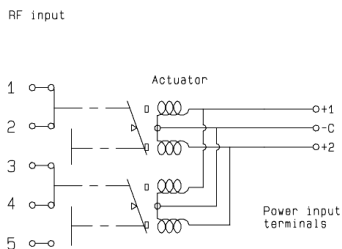

**WITH INDICATOR CONTACT**  
R585-4-000/R585-4-200/R585-4-400

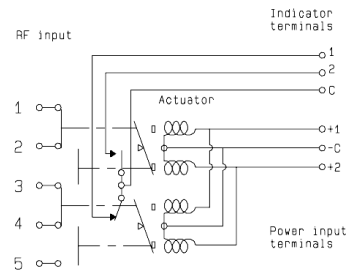

Electrical Schematics

**COAXIAL DP3T & TERMINATED SPDT**  
**R585 SERIES**  
**LATCHING**

**WITH SUPPRESSION DIODES**  
**R585-3-030/R585-3-230/R585-3-430**

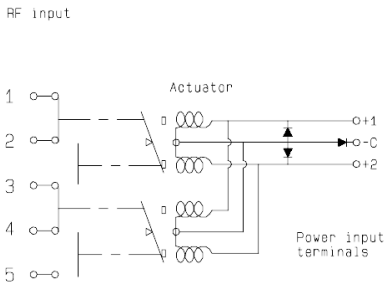

**WITH SUPPRESSION DIODES & INDICATOR CONTACT**  
**R585-4-030/R585-4-230/R585-4-430**

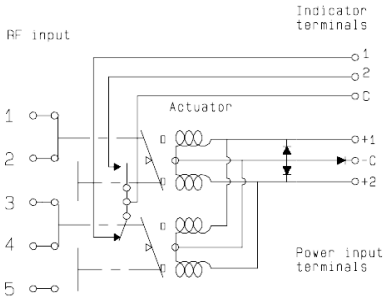

**WITH TTL DRIVER (SUPPRESSION DIODES ARE INCLUDED)**  
**R585-3-100/R585-3-300/R585-3-500**

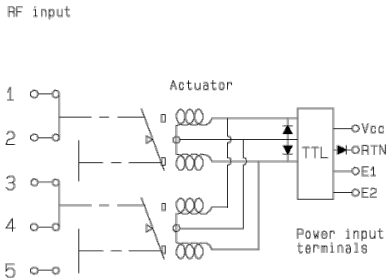

**WITH TTL DRIVER & INDICATOR CONTACT (SUPPRESSION DIODES ARE INCLUDED)**  
**R585-4-100/R585-4-300/R585-4-500**

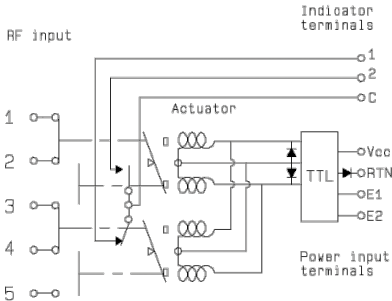

**WITH CUT-OFF (SUPPRESSION DIODES ARE INCLUDED)**  
**R585-5-000/R585-5-200/R585-5-400**

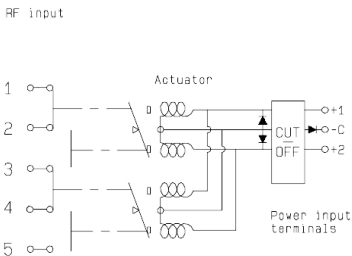

**WITH CUT-OFF & INDICATOR CONTACT (SUPPRESSION DIODES ARE INCLUDED)**  
**R585-6-000/ R585-6-200/R585-6-400**

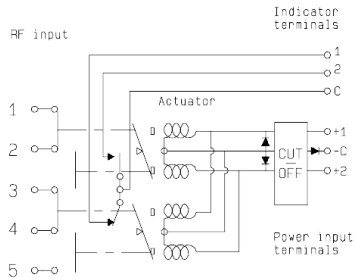

**COAXIAL DP3T & TERMINATED SPDT (CONTINUED)**

**R585 SERIES**

**LATCHING**

**WITH CUT-OFF & TTL DRIVER  
(SUPPRESSION DIODES ARE INCLUDED)  
R585-5-100/R585-5-300/R585-5-500**

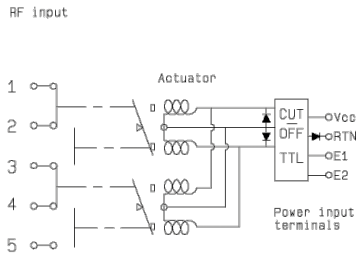

**WITH CUT-OFF, TTL DRIVER & INDICATOR CONTACT  
(SUPPRESSION DIODES ARE INCLUDED)  
R585-6-100/R585-6-300/R585-6-500**

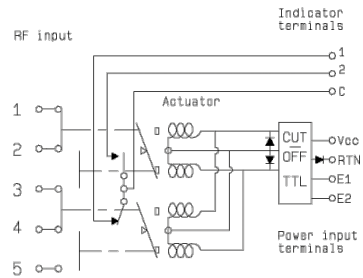

**WITH POSITIVE COMMON, NO OPTION  
R585-3-010/R585-3-210/R585-3-410**

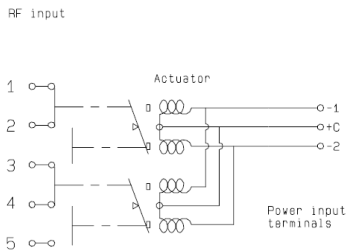

**WITH POSITIVE COMMON & INDICATOR CONTACT  
R585-4-010/R585-4-210/R585-4-410**

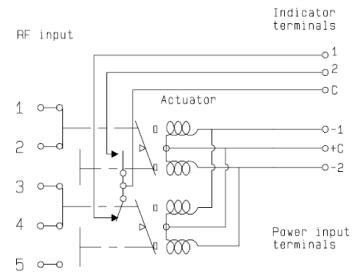

**WITH POSITIVE COMMON & SUPPRESSION DIODES  
R585-3-040/R585-3-240/R585-3-440**

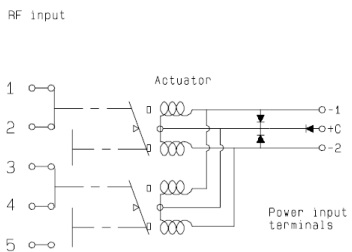

**WITH POSITIVE COMMON, SUPPRESSION DIODES & INDICATOR CONTACT  
R585-4-040/R585-4-240/R585-4-440**

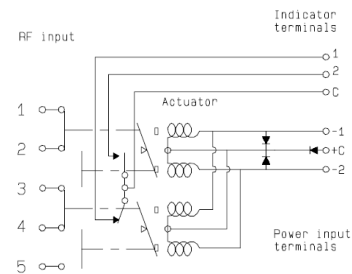



Electrical Schematics

COAXIAL DP3T & TERMINATED SPDT (CONTINUED)

R585 SERIES

LATCHING

WITH POSITIVE COMMON & CUT-OFF  
(SUPPRESSION DIODES ARE INCLUDED)  
R585-5-010/R585-5-210/R585-5-410

WITH POSITIVE COMMON, CUT-OFF & INDICATOR CONTACT  
(SUPPRESSION DIODES ARE INCLUDED)  
R585-6-010/R585-6-210/R585-6-410

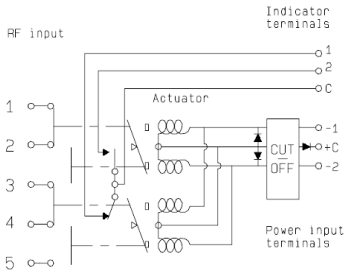
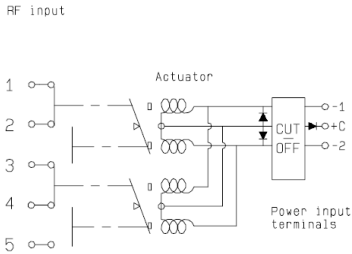

PIN IDENTIFICATION

TYPE	PIN						
	1	2	3	4	6	7	8
Failsafe	+		-				
Failsafe + I.C.	+		-		2NO	1NC	C
Failsafe + TTL	E		RTN	VCC			
Failsafe + I.C. + TTL	E		RTN	VCC	2NO	1NC	C
Latching Latching + Cut-off	-2 or +2	-1 or +1	+C or -C				
Latching + I.C. Latching + I.C. + Cut-off	-2 or +2	-1 or +1	+C or -C		2	1	C
Latching + TTL Latching + TTL + Cut-off	E2	E1	RTN	VCC			
Latching + TTL + I.C. Latching + TTL + I.C. + Cut-off	E2	E1	RTN	VCC	2	1	C
Normally open	-2 or +2	-1 or +1	+C or -C				
Normally open + I.C.	-2 or +2	-1 or +1	+C or -C		2	1	C
Normally open + TTL	E2	E1	RTN	VCC			
Normally open + TTL + I.C.	E2	E1	RTN	VCC	2	1	C

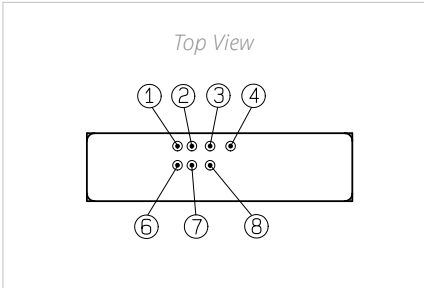

Platinum Series

**HIGH PERFORMANCE DP3T & TERMINATED SPDT UP TO 40 GHz**  
SMA - SMA 2.9



Radiall's PLATINUM series switches are optimized to perform at a high level over an extended life cycle. With outstanding RF performance, and a guaranteed insertion loss repeatability of 0.03 dB over a life span of 10 million switching cycles. PLATINUM series switches are perfect for automated test and measurement equipment, as well as signal monitoring devices.

*Example of P/N: R595F63215 is a Terminated SPDT SMA 26.5 GHz, latching with Self Cut-Off, 24 Vdc, Indicators, D-Sub connector.*

**PART NUMBER SELECTION**

**R595**

**SERIES PREFIX**

**RF CONNECTORS**

- 3: SMA up to 6 GHz <sup>[2]</sup>
- 4: SMA up to 20 GHz <sup>[2]</sup>
- F: SMA up to 26.5 GHz <sup>[2]</sup>
- 8: SMA 2.9 up to 40 GHz <sup>[1 & 3]</sup>

**TYPE**

- 3: Latching
- 4: Latching + I.C.
- 5: Latching + S.C.O.
- 6: Latching + S.C.O. + I.C.

**ACTUATOR VOLTAGE**

- 3: 24 Vdc
- 7: 15 Vdc

**SWITCH MODEL**

- 2: Terminated SPDT switch
- 3: Terminated 4 port bypass switch
- 4: Non-terminated 5 port DP3T switch

**OPTIONS**

- 1: Without option (positive common)
- 2: Compatible TTL driver

**ACTUATOR TERMINALS**

- 0: Solder pins
- 5: D-Sub connector

**DOCUMENTATION**

- : Certificate of conformity
- C: Calibration certificate
- R: Calibration certificate + RF curves

**Notes**

- I.C.: Indicator contact/S.C.O.: Self Cut-Off.
- 1. Connector SMA 2.9 is equivalent to "K connector", registered trademark of Anritsu.
- 2. The terminated models are fitted with internal terminations.
- 3. The terminated models are fitted with external terminations.

## Platinum Series

## GENERAL SPECIFICATIONS

OPERATING MODE		LATCHING	
Nominal operating voltage (across operating temperature)	Vdc	24 (20 to 32)	15 (12 to 20)
Coil resistance (+/-10%)	$\Omega$	175	60
Nominal operating current at 23 °C	mA	140	250
Average power		RF path - Cold switching: see Power Chart on page 3-23 Hot switching: 1 Watt CW	
		Internal terminations - 1 Watt average into 50 $\Omega$ External terminations - 1 Watt average into 50 $\Omega$	
TTL input	High Level	3 to 7 V: 800 $\mu$ A max at 7 V	
	Low Level	0 to 0.8 V: 20 $\mu$ A max at 0.8 V	
Switching time (max)	ms	15	
Life (min)	SMA	10 million cycles	
	SMA 2.9	5 million cycles	
Connectors		SMA - SMA 2.9	
Actuator terminals		D-Sub 9 pin female Solder pins	
Weight	g	< 100	

## ENVIRONMENTAL SPECIFICATIONS

Operating temperature range	-25 °C to +75 °C
Storage temperature range	-55 °C to +85 °C
Temperature cycling (MIL STD 202F, Method 107D, Cond.A)	-55 °C to +85 °C (10 cycles)
Sine vibration operating (MIL STD 202, Method 204D, Cond.D)	10-2,000 Hz, 20 g
Random vibration operating	16.91 G (rms) 50-2,000 Hz 3 min/axis
Shock operating (MIL STD 202, Method 213B, Cond.G)	50 g/11 ms, sawtooth
Humidity operating	15 to 95% relative humidity
Humidity storage (MIL STD 202, Method 106E, Cond.E)	65 °C, 95% RH, 10 days
Altitude operating	15,000 ft (4,600 meters)
Altitude storage (MIL STD 202, Method 105C, Cond.B)	50,000 ft (15,240 meters)

Platinum Series

RF PERFORMANCE

PART NUMBER		R5953-----	R5954-----		R595F-----		R5958-----		
Frequency Range	GHz	DC to 6	DC to 20		DC to 26.5		DC to 40		
Impedance	Ω	50							
Insertion Loss (max)	dB	0.20 + (0.45 / 26.5) x frequency (GHz)							
Isolation (min)		85	DC to 6 GHz 6 to 12.4 GHz 12.4 to 20 GHz	85 75 65	DC to 6 GHz 6 to 12.4 GHz 12.4 to 20 GHz 20 to 26.5 GHz	85 75 65 60	DC to 6 GHz 6 to 12.4 GHz 12.4 to 20 GHz 20 to 26.5 GHz 26.5 to 40 GHz	85 75 65 60 55	
V.S.W.R. (max)		1.15	DC to 6 GHz 6 to 12.4 GHz 12.4 to 20 GHz	1.15 1.25 1.30	DC to 6 GHz 6 to 12.4 GHz 12.4 to 20 GHz 20 to 26.5 GHz	1.15 1.25 1.30 1.60	DC to 6 GHz 6 to 12.4 GHz 12.4 to 20 GHz 20 to 26.5 GHz 26.5 to 40 GHz	1.15 1.25 1.30 1.60 1.80	
Repeatability (Up to 10 million cycles at 25 °C)		0.03 dB maximum					0.05 dB maximum		

INSERTION LOSS & ISOLATION

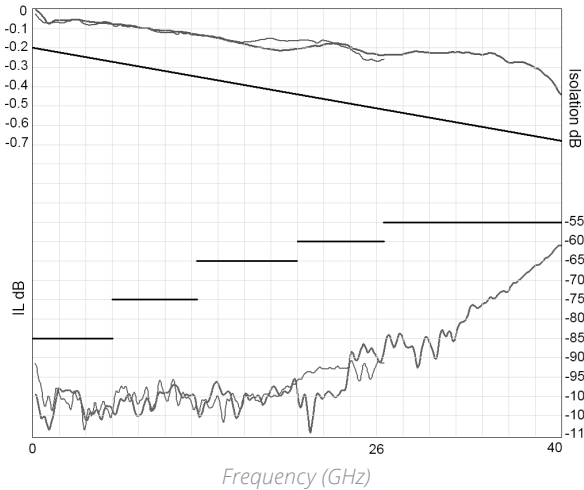

V.S.W.R.

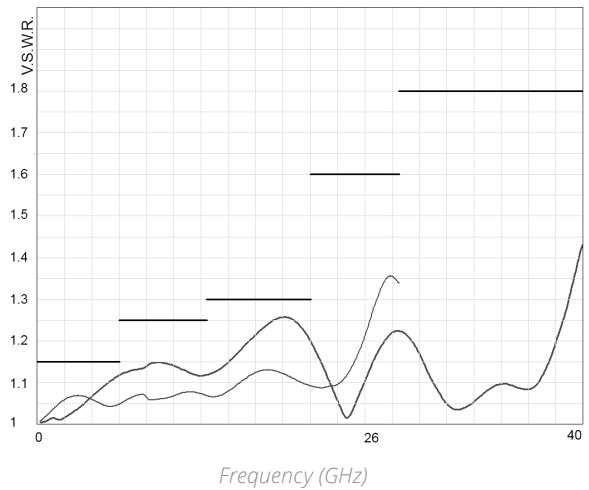

SMA — SMA 2.9 —

**SWITCH MODEL: NON-TERMINATED SPDT SWITCH**

The terminated SPDT switch is a single pole double throw switch where unused ports are terminated into 50 ohms. This switch is considered a “break-before-make.”

*RF Schematic Diagram*

**POSITION E1**

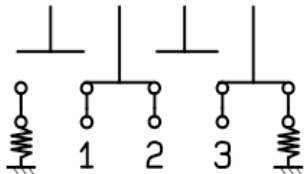

**POSITION E2**

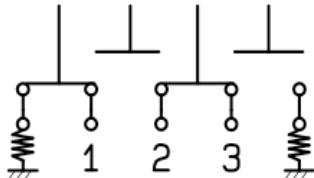

*Position Indicator*

**STATE 11**

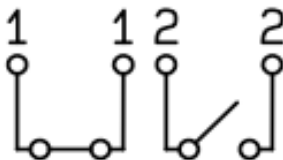

**STATE 22**

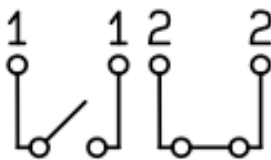

*Standard drive option “1”*

(Positive common):

- Connect pin +Vcc to supply (+20 Vdc to +32 Vdc)
- Select desired RF path by applying ground to the corresponding "close" pin (Ex: ground pin E1 to switch to position E1. RF path 1-2 closed and RF path 2-3 open)
- To open desired path and close the new RF path, connect ground to the corresponding "close" pin (Ex: ground pin E2 to open RF path 1-2 and close RF path 2-3)

*TTL drive option “2”*

- Connect pin GND to ground
- Connect pin +Vcc to supply (+20 Vdc to +32 Vdc)
- Select (close) desired RF path by applying TTL "High" to the corresponding "drive" pin. (Ex: apply TTL "High" to pin E1 to switch to position E1. RF path 1-2 closed and RF path 2-3 open)
- To open desired path and close the new RF path, apply TTL "High" to the "drive" pin which corresponds to the desired RF path. (Ex: apply TTL "High" to pin E2 to open RF path 1-2 and close RF path 2-3)

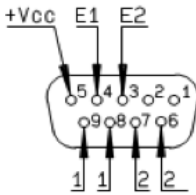

D-Sub connector

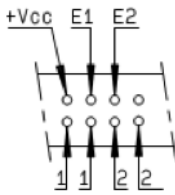

Solder pins

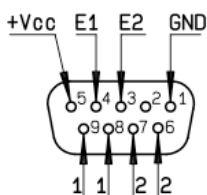

D-Sub connector

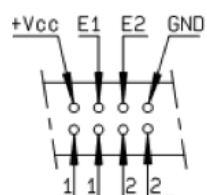

Solder pins

SWITCH MODEL: TERMINATED SPDT SWITCH

WITH D-SUB CONNECTOR

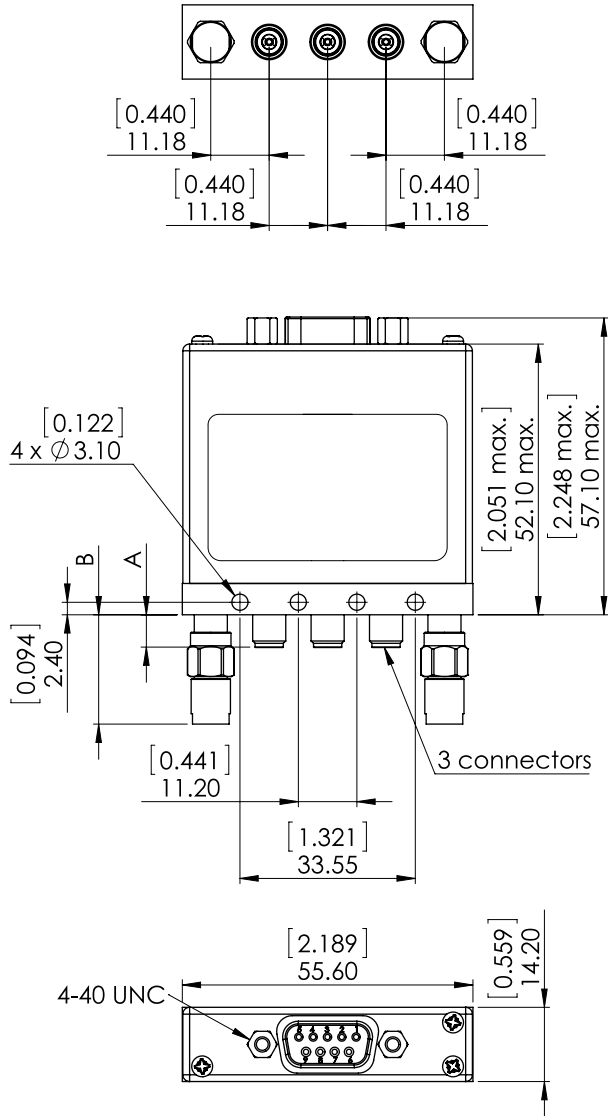

WITH SOLDER PINS

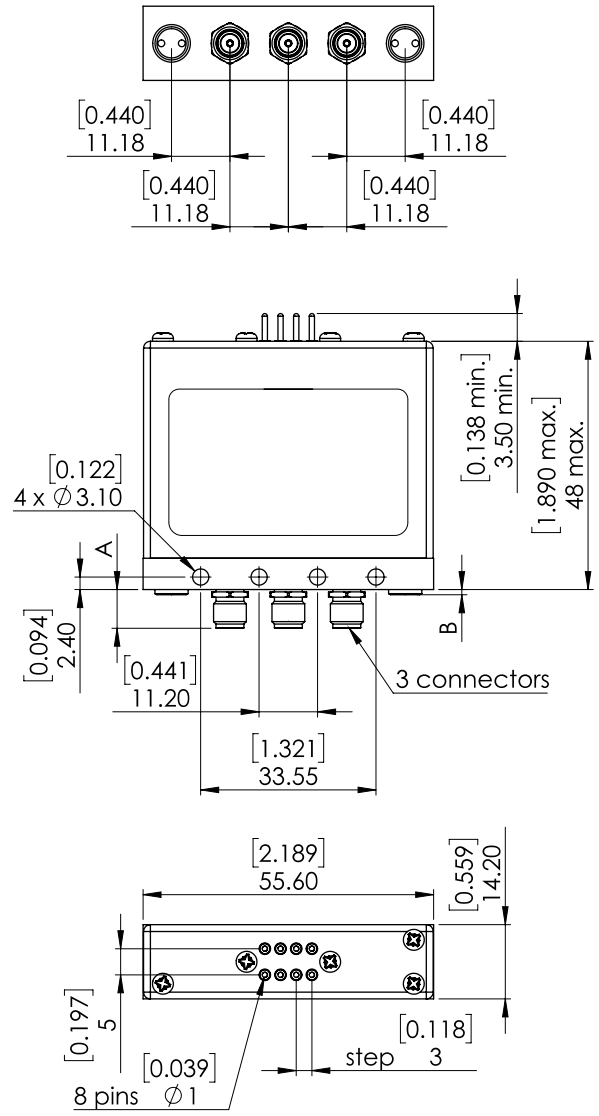

CONNECTORS	A MAX (MM [INCHES])	B MAX (MM [INCHES])	TERMINATIONS
SMA	7.7 [0.303]	1.5 [0.059]	Internal
SMA 2.9	6.7 [0.264]	21 [0.827]	External

Notes

All dimensions are in millimeters [inches].

Platinum Series

**SWITCH MODEL: TERMINATED 4-PORT BYPASS SWITCH**

The terminated 4 port bypass switch can terminate into the 50 ohms device under test.

This switch is considered a “break-before-make.”

*RF Schematic Diagram*

**POSITION E1**

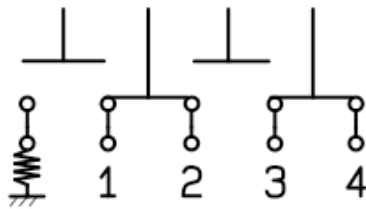

**POSITION E2**

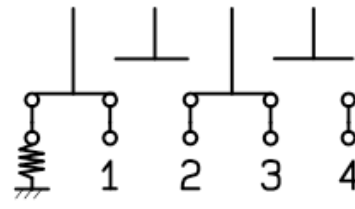

*Position Indicators*

**STATE 11**

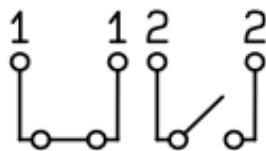

**STATE 22**

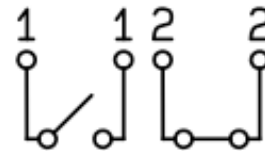

*Standard drive option “1”*

*(Positive common):*

- Connect pin +Vcc to supply (+20 Vdc to +32 Vdc).
- Select desired RF path by applying ground to the corresponding "close" pin (Ex: ground pin E1 to switch to position E1. RF path 1-2 and RF path 3-4 closed and RF path 2-3 open).
- To open desired path and close the new RF path, connect ground to the corresponding "close" pin (Ex: ground pin E2 to open RF path 1-2 and 3-4 and close RF path 2-3).

*TTL drive option “2”*

- Connect pin GND to ground
- Connect pin +Vcc to supply (+20 Vdc to +32 Vdc)
- Select (close) desired RF path by applying TTL "High" to the corresponding "drive" pin (Ex: apply TTL "High" to pin E1 to switch to position E1. RF path 1-2 and 3-4 closed and RF path 2-3 open)
- To open desired path and close the new RF path, apply TTL "High" to the "drive" pin which corresponds to the desired RF path (Ex: apply TTL "High" to pin E2 to open RF path 1-2 and 3-4 and close RF path 2-3)

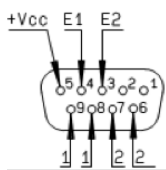

*D-Sub connector*

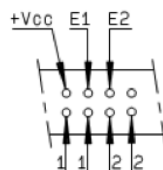

*Solder pins*

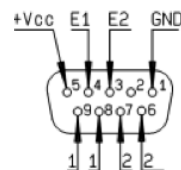

*D-Sub connector*

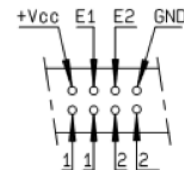

*Solder pins*

Platinum Series

WITH D-SUB CONNECTOR

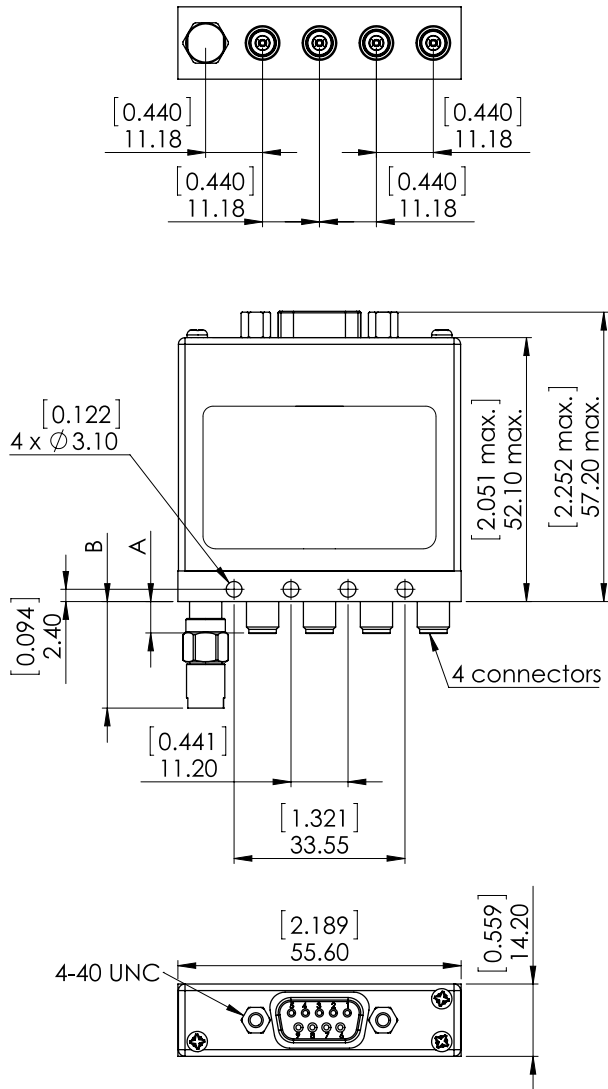

WITH SOLDER PINS

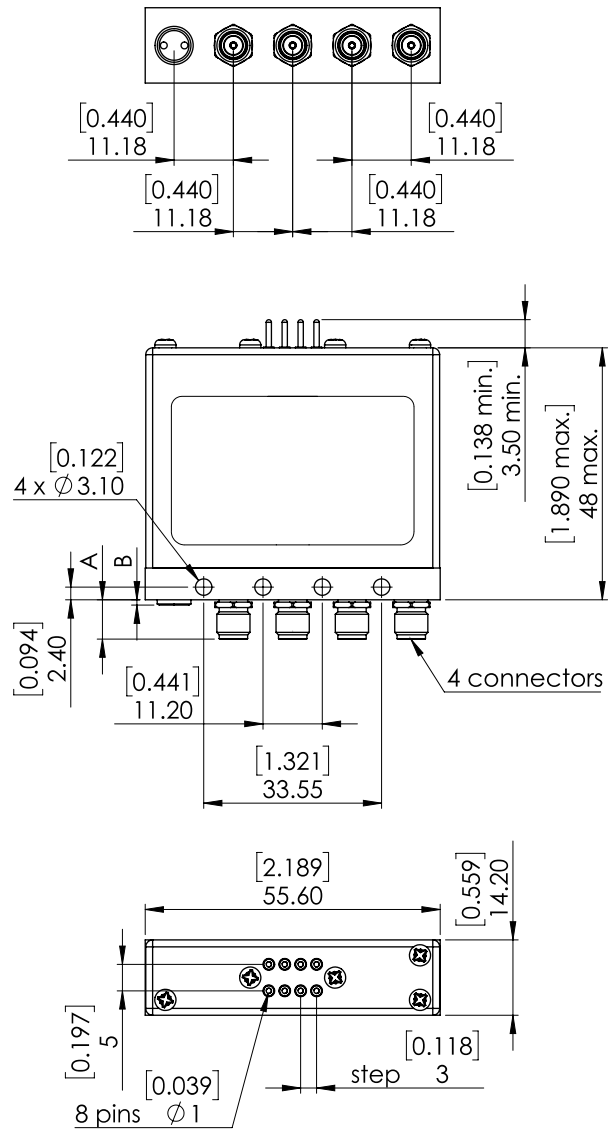

CONNECTORS	A MAX (MM [INCHES])	B MAX (MM [INCHES])	TERMINATIONS
SMA	7.7 [0.303]	1.5 [0.059]	Internal
SMA 2.9	6.7 [0.264]	21 [0.827]	External

Notes

All dimensions are in millimeters [inches].



**SWITCH MODEL: TERMINATED 5-PORT DP3T SWITCH**

The non-terminated 5 port DP3T switch can be used as SPDT with high power terminations, as a bypass switch. In this application, the fifth port can be terminated externally with a high power termination. These switches are considered a "break-before-make."

*RF Schematic Diagram*

**POSITION E1**

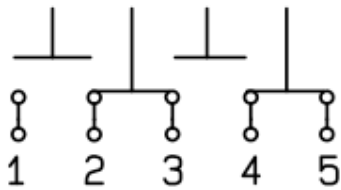

**POSITION E2**

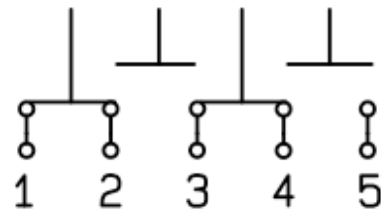

*Position Indicators*

**STATE 11**

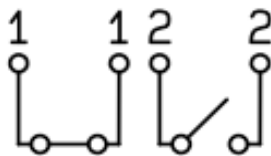

**STATE 22**

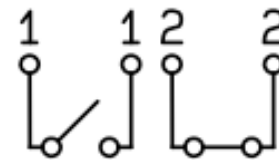

**Standard drive option "1"**  
(Positive common):

- Connect pin +Vcc to supply (+20 Vdc to +32 Vdc)
- Select desired RF path by applying ground to the corresponding "close" pin (Ex: ground pin E1 to switch to position E1. RF path 2-3 and RF path 4-5 closed and RF path 1-2 and RF path 3-4 open)
- To open desired path and close the new RF path, connect ground to the corresponding "close" pin (Ex: ground pin E2 to open RF path 2-3 and 4-5 and close RF path 1-2 and 3-4)

**TTL drive option "2"**

- Connect pin GND to ground
- Connect pin +Vcc to supply (+20 Vdc to +32 Vdc)
- Select (close) desired RF path by applying TTL "High" to the corresponding "drive" pin (Ex: apply TTL "High" to pin E1 to switch to position E1. RF path 2-3 and RF path 4-5 closed and RF path 1-2 and 3-4 open)
- To open desired path and close the new RF path, apply TTL "High" to the "drive" pin which corresponds to the desired RF path. (Ex: apply TTL "High" to pin E2 to open RF path 2-3 and 4-5 and close RF path 1-2 and 3-4)

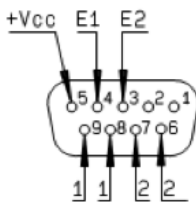

D-Sub connector

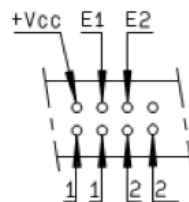

Solder pins

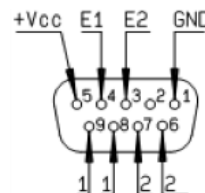

D-Sub connector

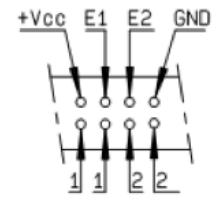

Solder pins

NON-TERMINATED 5 PORT DP3T SWITCH

WITH D-SUB CONNECTOR

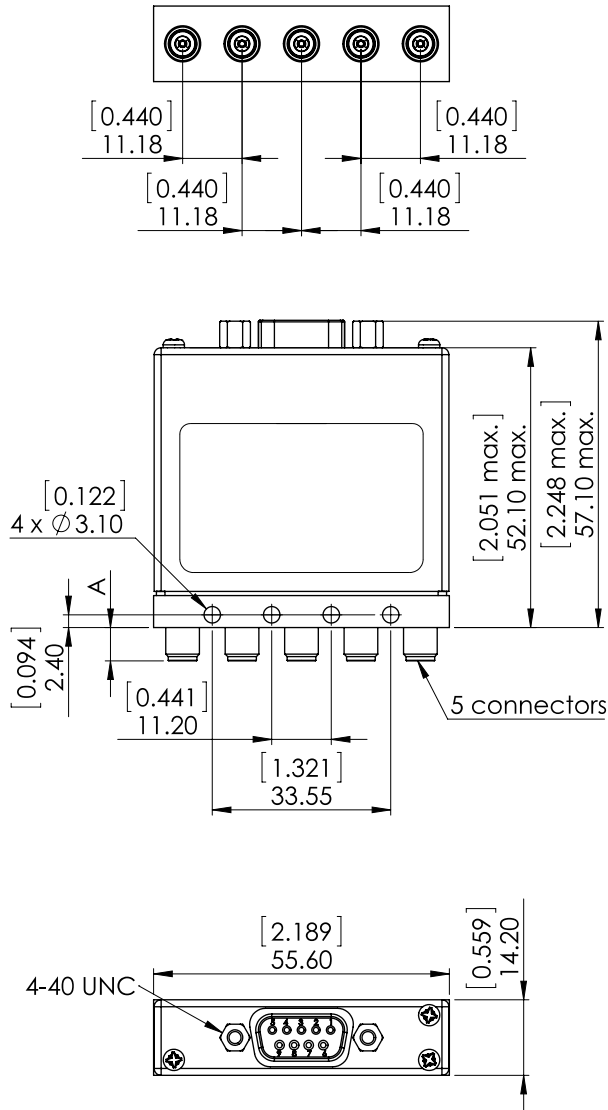

WITH SOLDER PINS

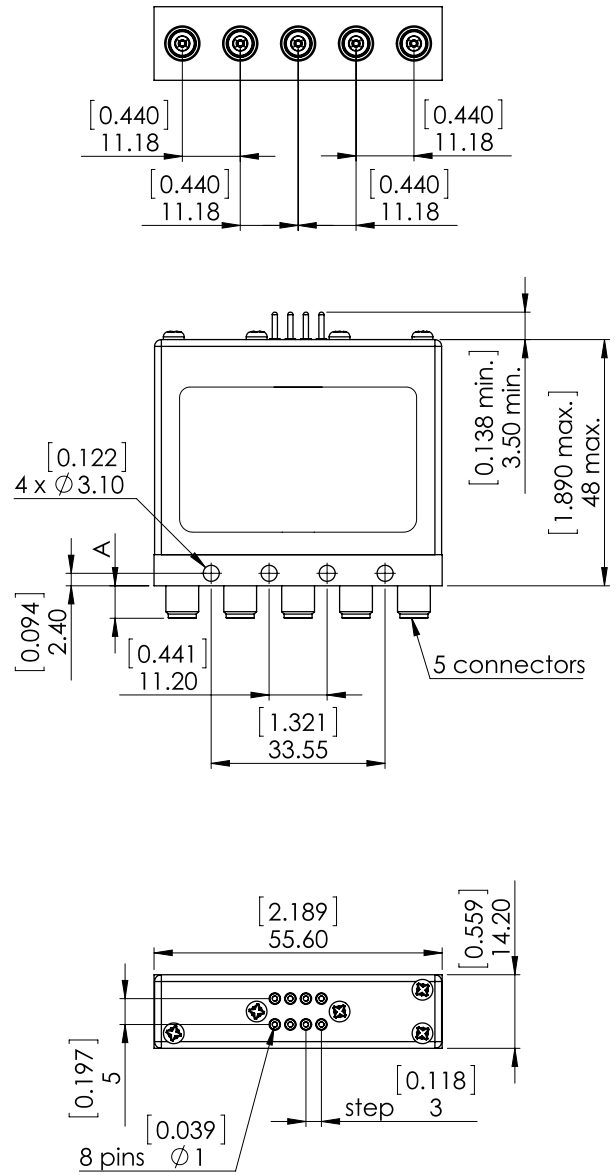

CONNECTORS	A MAX (MM [INCHES])
SMA	7.7 [0.303]
SMA 2.9	6.7 [0.264]

Notes

All dimensions are in millimeters [inches].

Platinum Series

**POWER RATING CHART**

This graph is based on the following conditions:

- Ambient temperature: + 25 °C
- Sea level
- V.S.W.R.: 1 and cold switching

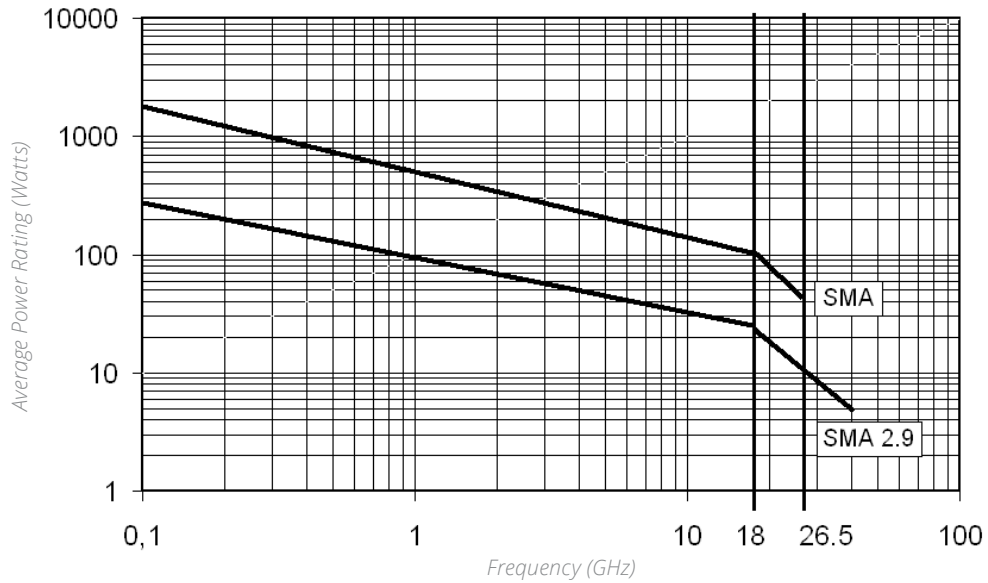

**DERATING FACTOR VERSUS VSWR**

The average power input must be reduced for load V.S.W.R. above 1:1

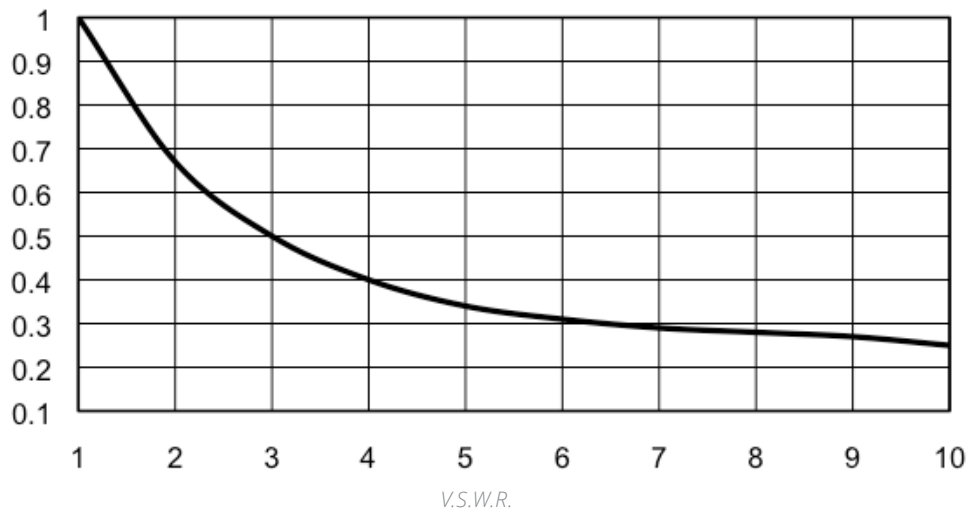

Optional Features

**OPTIONAL FEATURES FOR DP3T SWITCHES**

**GENERAL**

RADIALL DP3T / SPDT terminated are only designed with SMA, SMA 2.9 and 2.4 mm connectors. For all other connectors (N, BNC etc.), the same function as SPDT terminated can be easily performed with a standard DPDT and an external load.

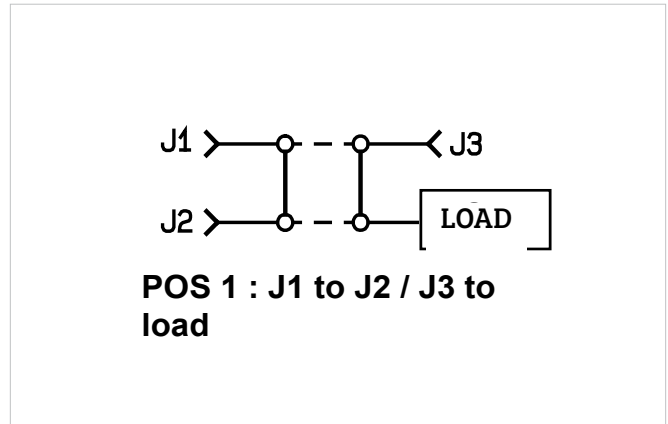

**EXAMPLES OF DEDICATED APPLICATIONS**



This SPDT terminated switch is composed of a DP3T with SMA connectors, and cable load for medium power terminations. The Key advantage of this solution is the ability to mount the switch with external terminations at the desired power level.



This is an example of an SPDT terminated switch that was designed with two separate coils for a specific test network application.



## DPDT

---



Section 4 Table of Contents

**RAMSES SERIES**

DPDT up to 50 GHz: R577 miniature ..... 4-2 to 4-5  
 DPDT up to 12.4 GHz RAMSES Concept: N, BNC and TNC models ..... 4-6 to 4-9

**ELECTRICAL SCHEMATICS**

Coaxial DPDT: R577 Series ..... 4-10 to 4-13

**TITANIUM SERIES**

High performance DPDT Series DC - 40 GHz: R513 Series ..... 4-14 to 4-19

**PLATINUM SERIES**

High performance DPDT up to 40 GHz: R593 Series ..... 4-20 to 4-25

**OPTIONAL FEATURES**

Optional Features for DPDT switches ..... 4-26

**DPDT PART NUMBER SELECTION GUIDE<sup>[1]</sup>**

PLATINUM		TITANIUM		RAMSES		DIGITAL POSITION	
DPDT	R593	DPDT	R513	DPDT	R577	DPDT	R 1-3
-	-	-	-	-	-	-	-
3	3	3	3	-	3	3	SMA 3 GHz
-	-	-	-	-	-	-	SMA 6 GHz
4	4	4	4	-	4	4	SMA 18 GHz
F	F	F	F	-	F	F	SMA 20 GHz
8	8	8	8	-	8	8	SMA 26.5 GHz
-	-	-	-	-	-	-	SMA 2.9 40 GHz
-	-	-	-	-	-	-	2.4 mm up to 50 GHz
-	-	-	-	-	-	-	QMA 6 GHz
-	-	-	-	-	-	-	DIN 1.6/5.6, 2.5 GHz
-	-	-	-	0	0	0	N 3 GHz
-	-	-	-	1	1	1	N 12.4 GHz
-	-	-	-	2	2	2	BNC 3 GHz
-	-	-	-	5	5	5	TNC 3 GHz
-	-	-	-	6	6	6	TNC 12.4 GHz
-	-	-	-	1/2	1/2	1/2	Failsafe
7	7	7	7	3/4/5/6	3/4/5/6	3/4/5/6	Latching
-	-	-	-	2	2	2	12 V
3	3	3	3	-	-	-	24 V
-	-	-	-	3	3	3	28 V
-	-	-	-	0	0	0	Without
1	1	1	1	1	1	1	With option
-	-	-	-	0	0	0	Without option
-	-	-	-	1	1	1	Positive common
-	-	-	-	3	3	3	Suppression diodes
4	4	4	4	4	4	4	Suppression diodes and positive common
-	-	-	-	0	0	0	Solder pins with bracket
-	-	-	-	2	2	2	Solder pins without bracket
-	-	-	-	5	5	5	D-Sub connector with bracket
-	-	-	-	7	7	7	D-Sub connector without bracket
8	8	8	8	-	-	-	HE 10 with bracket
9	9	9	9	-	-	-	HE 10 without bracket

**Notes**

Example of P/N: R577412020 is a DPDT SMA 18 GHz failsafe, 12 Vdc, without TTL driver, solder pins with bracket.

1. For part number creation and available options, see detailed part number selection for each series.

## DPDT UP TO 50 GHz

SMA - SMA 2.9 - 2.4 MM - QMA - DIN 1.6/5.6



Radiall's DPDT switches offer excellent reliability, high performance and operating frequencies from DC to 50 GHz. Radiall's RAMSES concept guarantees a life span of 2.5 million cycles and provides a full array of options to respond to the needs of our customers.

These relays are well suited for applications across all markets including: Defense, Instrumentation, and Telecom.

*Example of P/N: R577F63105 is a DPDT SMA 26.5 GHz latching with Indicators, Self Cut-Off, 28 Vdc, TTL driver, D-Sub connector.*

### PART NUMBER SELECTION

# R577

#### SERIES PREFIX

#### RF CONNECTORS

- 3: SMA up to 6 GHz
- 4: SMA up to 20 GHz
- F: SMA up to 26.5 GHz
- 8: SMA 2.9 up to 40 GHz <sup>[5]</sup>
- 9: DIN 1.6/5.6 up to 2.5 GHz
- J: 2.4 mm up to 50 GHz

#### TYPE

- 1: Failsafe
- 2: Failsafe + I.C.
- 3: Latching
- 4: Latching + I.C.
- 5: Latching + S.C.O. <sup>[1]</sup>
- 6: Latching + S.C.O. + I.C. <sup>[1]</sup>

#### ACTUATOR VOLTAGE

- 2: 12 Vdc
- 3: 28 Vdc

#### ACTUATOR TERMINALS & FIXING

- 0: Solder pins with bracket
- 2: Solder pins without bracket
- 5: D-Sub connector with bracket
- 7: D-Sub connector without bracket

#### OPTIONS

- 0: Without option
- 1: Positive common <sup>[2 & 3]</sup>
- 3: With suppression diodes <sup>[1]</sup>
- 4: With suppression diodes and positive common <sup>[2 & 3]</sup>

#### TTL OPTION

- 0: Without TTL driver
- 1: With TTL driver <sup>[1 & 2]</sup>

### Notes

I.C.: Indicator contact/S.C.O.: Self Cut-Off.

1. Suppression diodes are already included in self cut-off & TTL option.

2. Polarity is not relevant to application for switches with TTL driver.

3. Positive common shall be specified only with type 3,4,5 and 6 because failsafe switches can be used with both polarities.

4. The QLF trademark (Quick Lock Formula®) standard applies to QMA and QN series and guarantees the full intermateability between suppliers using this trademark. Using QLF certified connectors also guarantees the specified level of RF performance.

5. Connector SMA 2.9 is equivalent to "K connector®", registered trademark of Anritsu.





## RAMSES Series

## GENERAL SPECIFICATIONS

OPERATING MODE		FAILSAFE		LATCHING	
Nominal operating voltage (across operating temperature)	Vdc	12 (10.2 / 13)	28 (24 / 30)	12 (10.2 / 13)	28 (24 / 30)
Coil resistance (+/-10%)	Ω	35	200	38	225
Nominal operating current at 23 °C	mA	340	140	320	125
Average power		See Power Rating Chart page 1-13			
TTL input	High Level	2.2 to 5.5 Volts - 800 μA max 5.5 Volts			
	Low Level	0 to 0.8 Volts - 20 μA max 0.8 Volts			
Indicator rating		1 W/30 V/100 mA			
Switching time (max)	ms	15			
Life	SMA - SMA 2.9 - QMA - DIN 1.6/5.6	2.5 million cycles			
	2.4 mm	2 million cycles			
Connectors		SMA - SMA 2.9 - QMA - DIN 1.6/5.6 - 2.4 mm			
Actuator terminals		Solder pins or male 9 pin D-Sub connector			
Operating temperature range	DIN 1.6/5.6 - 2.4 mm	-25°C to +70°C			
	SMA - SMA 2.9 - QMA	-40°C to +85°C			
Storage temperature range	DIN 1.6/5.6 - 2.4 mm	-40°C to +85°C			
	SMA - SMA 2.9 - QMA	-55°C to +85°C			
Vibration (MIL STD 202, Method 204D, Cond. C)		10-2,000 Hz, 10g		operating	
Shock (MIL STD 202, Method 213B, Cond. G)		50 g/11 ms, ½ sine		operating	

## RF PERFORMANCE

CONNECTORS	FREQUENCY RANGE GHz		V.S.W.R. (MAX)	INSERTION LOSS (MAX) dB	ISOLATION (MIN) dB	IMPEDANCE Ω
DIN 1.6/5/6	DC - 2.5	DC - 1	1.20	0.20	80	75
		1 - 25	1.30	0.30	70	
QMA	DC - 6	DC - 3	1.20	0.20	80	50
		3 - 6	1.20	0.30	70	
SMA	DC - 3 DC - 18 DC - 26.5	DC - 3	1.20	0.20	80	50
		3 - 8	1.30	0.30	70	
		8 - 12.4	1.40	0.40	65	
		12.4 - 18	1.50	0.50	60	
SMA 2.9	DC - 40	18 - 26.5	1.70	0.70	50	50
		DC - 6	1.30	0.30	70	
		6 - 12.4	1.40	0.40	60	
		12.4 - 18	1.50	0.50	60	
2.4 mm	DC - 50	18 - 26.5	1.70	0.70	55	50
		26.5 - 40	1.90	0.80	50	
		40 - 50	2.00	1.10	50	
		DC - 6	1.30	0.30	70	
2.4 mm	DC - 50	6 - 12.4	1.40	0.40	60	50
		12.4 - 18	1.50	0.50	60	
		18 - 26.5	1.70	0.70	55	
		26.5 - 40	1.90	0.80	50	

See page 4-4 for typical RF performance.

**R577 TYPICAL RF PERFORMANCE**

*Example: DPDT SMA up to 26.5 GHz*

**INSERTION LOSS & ISOLATION**

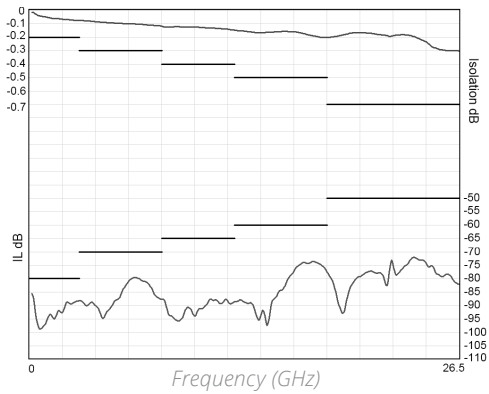

**V.S.W.R**

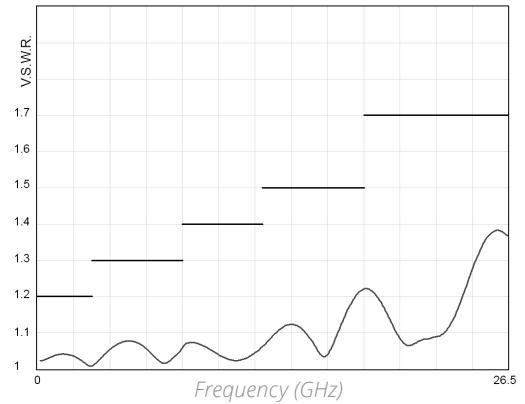

*Example: DPDT SMA 2.9 up to 40 GHz*

**INSERTION LOSS & ISOLATION**

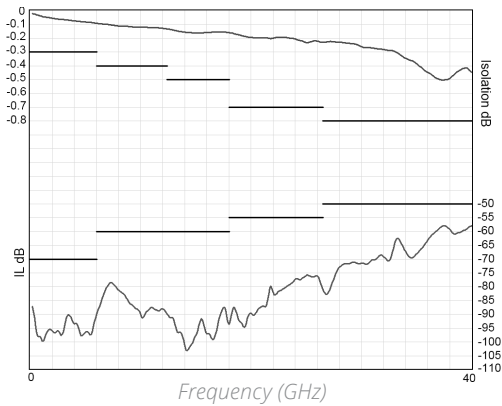

**V.S.W.R**

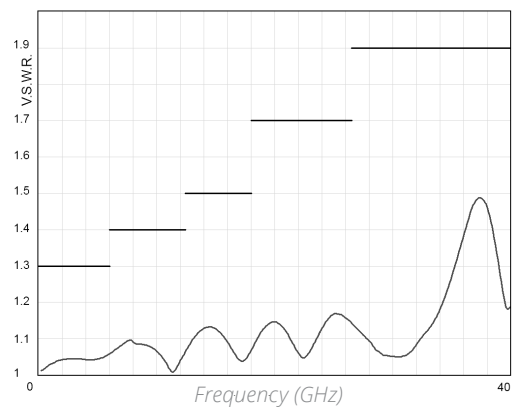

*Example: DPDT 2.4 mm up to 50 GHz*

**INSERTION LOSS & ISOLATION**

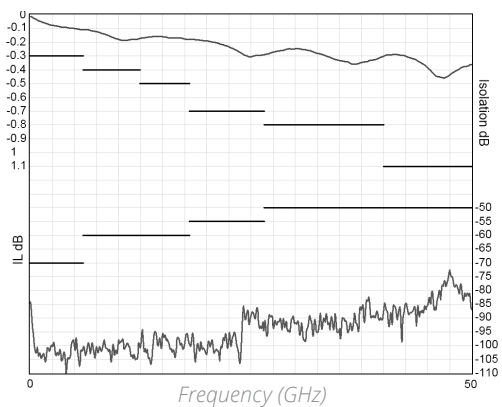

**V.S.W.R**

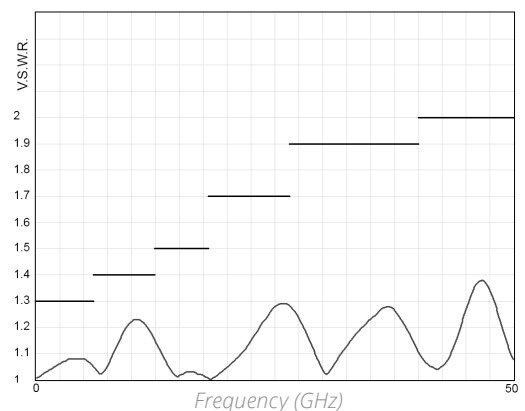

RAMSES Series

TYPICAL OUTLINE DRAWING

WITH SOLDER PINS & BRACKET

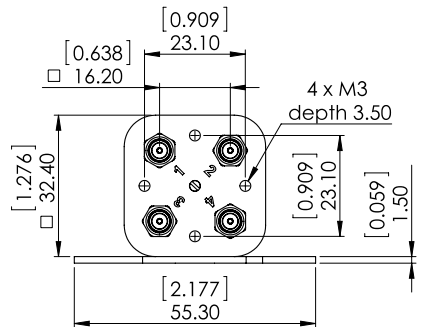

WITH D-SUB CONNECTOR & BRACKET

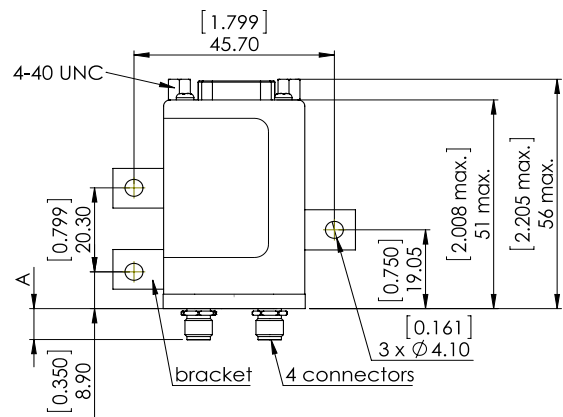
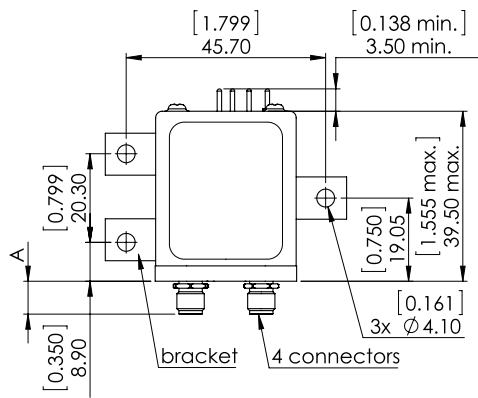
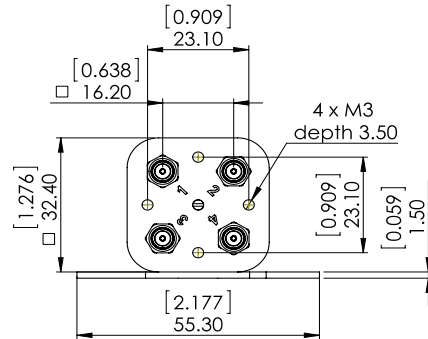

CONNECTORS	SMA	SMA 2.9 & 2.4 MM	QMA	DIN 1.6/5.6
A max (mm [inches])	7.7 [0.303]	6.7 [0.264]	10.8 [0.394]	11.5 [0.433]

ACCESSORIES

A printed circuit board interface connector (ordered separately) has been designed for easy mounting on terminals. For DPDT model R577 series = Radiall part number: R599 910 000

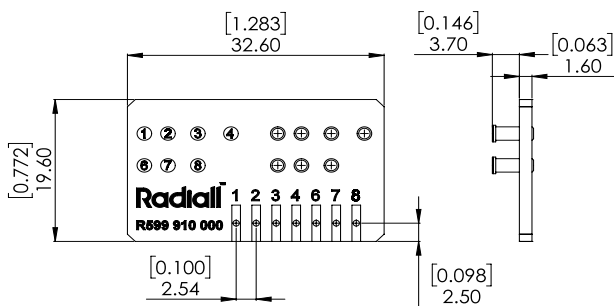

(Ø0.8 [0.031] metallized holes, double side tracks)



Notes

All dimensions are in millimeters [inches]. PCB accessory pin number assignment is independant from the pin identification table of the switch.

**DPDT UP TO 12.4 GHz - RAMSES Concept**  
**N - BNC - TNC**



Radiall's DPDT switches offer excellent reliability, high performance and operating frequencies from DC to 12.4 GHz. Radiall's RAMSES concept guarantees a life span of 2.5 million cycles and provides a full array of options to respond to the needs of our customers.

These relays are well suited for applications across all markets including: Defense, Instrumentation, and Telecom.

*Example of P/N: R577122030 is a DPDT N 12.4 GHz, failsafe with Indicators, 12 Vdc, suppression diodes, solder pins with bracket.*

**PART NUMBER SELECTION**

**R577**

**SERIES PREFIX**

**RF CONNECTORS**

- 0: N up to 3 GHz
- 1: N up to 12.4 GHz
- 2: BNC up to 3 GHz
- 5: TNC up to 3 GHz
- 6: TNC up to 12.4 GHz

**TYPE**

- 1: Failsafe
- 2: Failsafe + I.C.
- 3: Latching
- 4: Latching + I.C.
- 5: Latching + S.C.O. <sup>[1]</sup>
- 6: Latching + S.C.O. + I.C. <sup>[1]</sup>

**ACTUATOR VOLTAGE**

- 2: 12 Vdc
- 3: 28 Vdc

**TTL OPTION**

- 0: Without TTL driver
- 1: With TTL driver <sup>[1 & 2]</sup>

**OPTIONS**

- 0: Without option
- 1: Positive common <sup>[2 & 3]</sup>
- 3: With suppression diodes <sup>[1]</sup>
- 4: With suppression diodes and positive common <sup>[2 & 3]</sup>

**ACTUATOR TERMINALS & FIXING**

- 0: Solder pins with bracket
- 2: Solder pins without bracket
- 5: D-Sub connector with bracket
- 7: D-Sub connector without bracket

**Notes**

- I.C.: Indicator contact/S.C.O.: Self Cut-Off.
- 1. Suppression diodes are already included in self cut-off & TTL option.
- 2. Polarity is not relevant to application for switches with TTL driver.
- 3. Positive common shall be specified only with type 3,4,5 and 6 because failsafe switches can be used with both polarities.

## RAMSES Series

## GENERAL SPECIFICATIONS

OPERATING MODE		FAILSAFE		LATCHING	
Nominal operating voltage (across operating temperature)	Vdc	12 (10.2 / 13)	28 (24 / 30)	12 (10.2 / 13)	28 (24 / 30)
Coil resistance (+/-10%)	$\Omega$	35	200	38	225
Nominal operating current at 23°C	mA	340	140	320	125
Average power		See Power Rating Chart page 1-13			
TTL input	High Level	2.2 to 5.5 Volts			
	Low Level	0 to 0.8 Volts			
Indicator rating		1 W / 30 V / 100 mA			
Switching time (max)	ms	15			
Life		2.5 million cycles			
Connectors		N - BNC - TNC			
Actuator terminals		Solder pins or male 9 pin D-Sub connector			
Operating temperature range		-40°C to +85°C			
Storage temperature range		-55°C to +85°C			
Vibration (MIL STD 202, Method 204D, cond. C)		10 - 2,000 Hz, 10g		operating	
Shock (MIL STD 202, Method 213B, cond. G)		50 g / 11 ms, ½ sine		operating	

## RF PERFORMANCE

CONNECTORS	FREQUENCY RANGE GHz	V.S.W.R. (MAX)	INSERTION LOSS (MAX) dB	ISOLATION (MIN) dB	IMPEDANCE $\Omega$	
BNC	DC - 3	DC - 1	1.15	0.15	85	50
		1 - 2	1.20	0.20	80	
		2 - 3	1.25	0.25	75	
N - TNC	DC - 3 DC - 12.4	DC - 1	1.15	0.15	85	
		1 - 2	1.20	0.20	80	
		2 - 3	1.25	0.25	75	
		3 - 8	1.35	0.35	70	
		8 - 12.4	1.50	0.50	60	

See page 4-8 for typical RF performance.

**R577 TYPICAL RF PERFORMANCE**

*Example: DPDT N/TNC up to 12.4 GHz*

**INSERTION LOSS & ISOLATION**

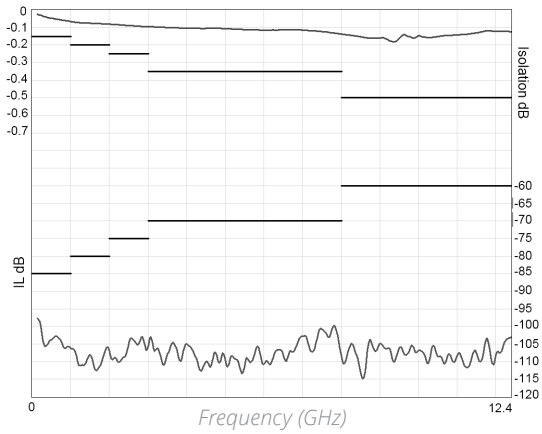

**V.S.W.R**

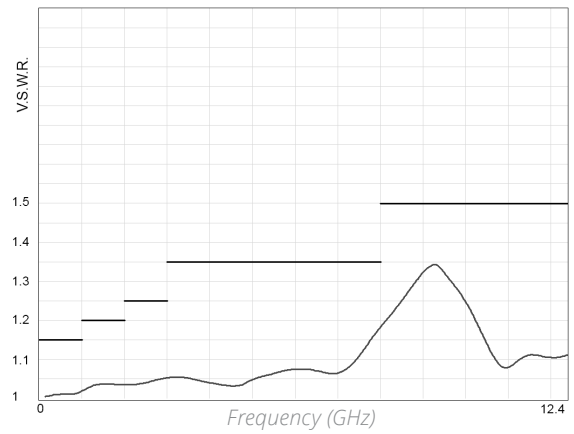

*Example: DPDT BNC up to 3 GHz*

**INSERTION LOSS & ISOLATION**

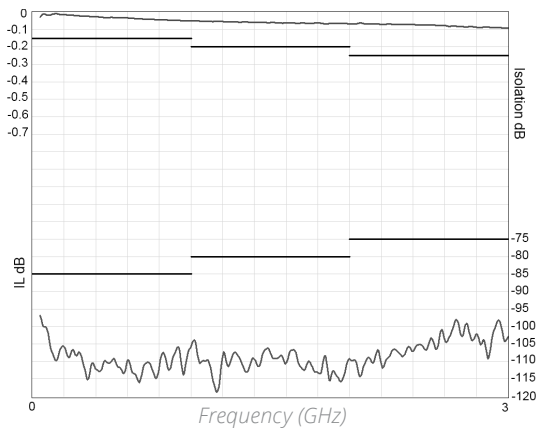

**V.S.W.R**

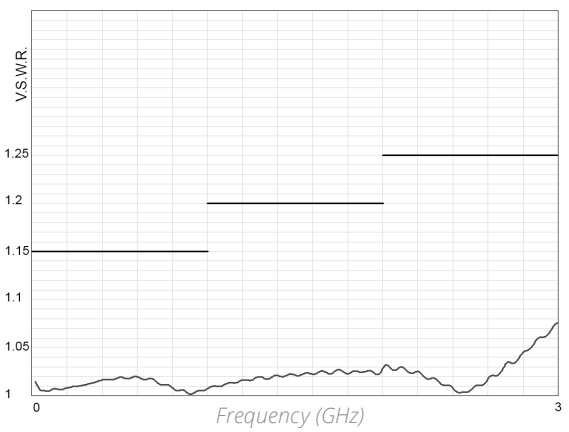

RAMSES Series

TYPICAL OUTLINE DRAWING

WITH SOLDER PINS & BRACKET

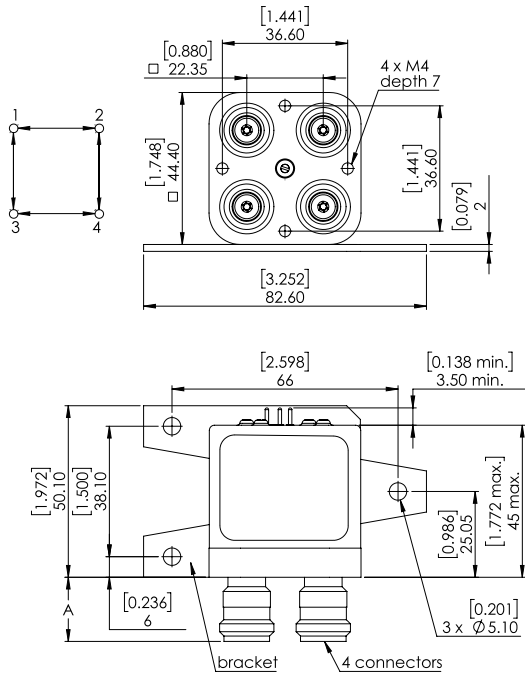

WITH D-SUB CONNECTOR & BRACKET

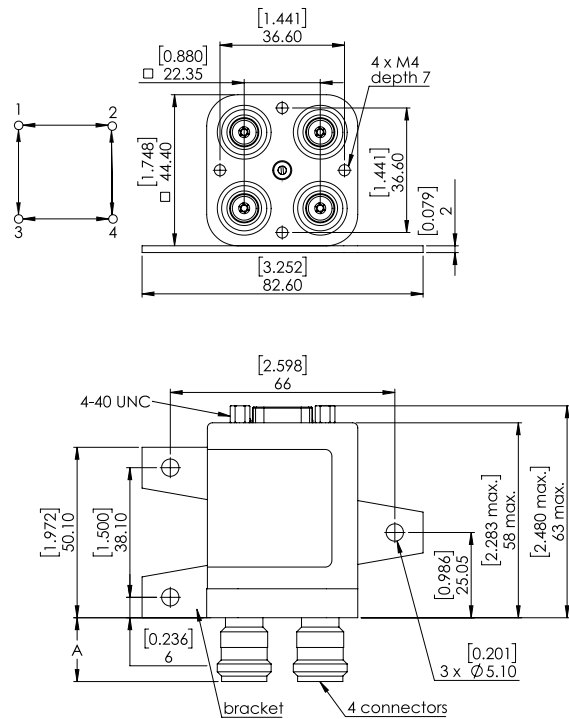

CONNECTORS	N	BNC	TNC
A max (mm [inches])	19.5 [0.748]	12.5 [0.472]	12.5 [0.472]

ACCESSORIES

A printed circuit board interface connector (ordered separately) has been designed for easy mounting on terminals. For DPDT model R577 series = Radiall part number: R599 910 000

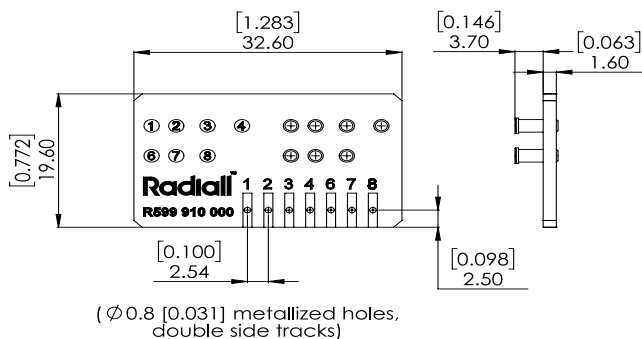

Notes

All dimensions are in millimeters [inches].  
See page 4-13 for pin allocation.

## COAXIAL DPDT

### R577 SERIES

#### FAILSAFE

WITHOUT OPTION  
R577-1-000

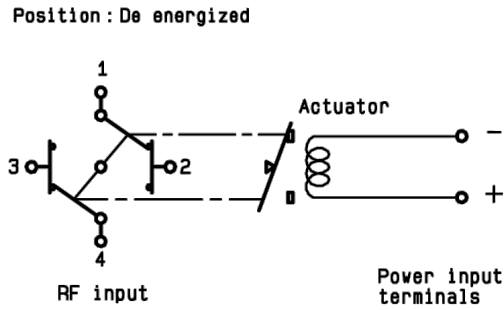

WITH INDICATOR CONTACT  
R577-2-000

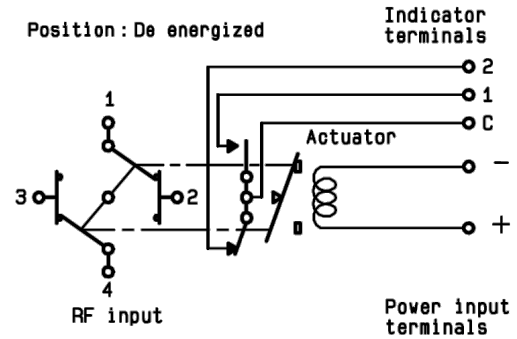

WITH SUPPRESSION DIODES  
R577-1-030

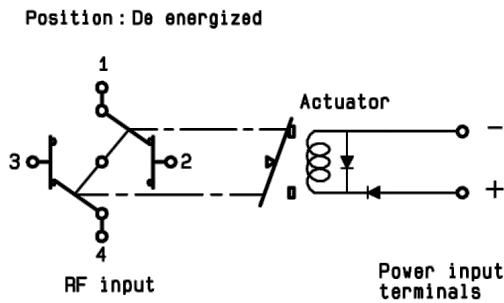

WITH SUPPRESSION DIODES & INDICATOR CONTACT  
R577-2-030

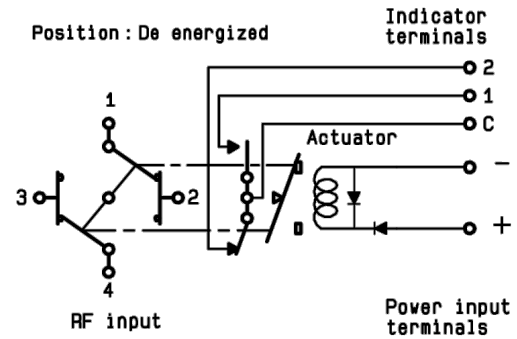

WITH TTL DRIVER (SUPPRESSION DIODES ARE INCLUDED)  
R577-1-100

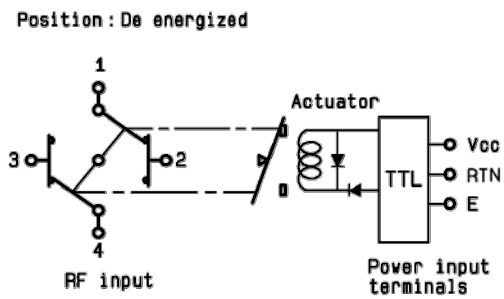

WITH TTL DRIVER & INDICATOR CONTACT  
(SUPPRESSION DIODES ARE INCLUDED)  
R577-2-100

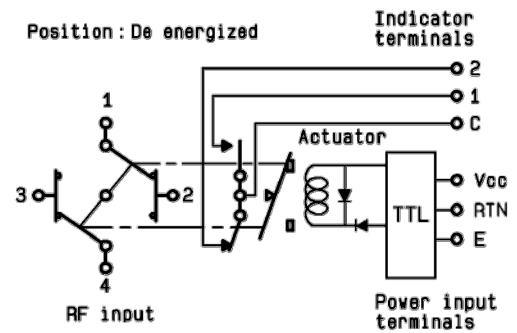



## COAXIAL DPDT

### R577 SERIES

#### LATCHING

#### WITHOUT OPTION

R577-3-000

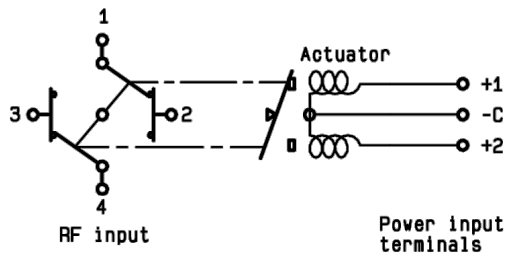

#### WITH INDICATOR CONTACT

R577-4-000

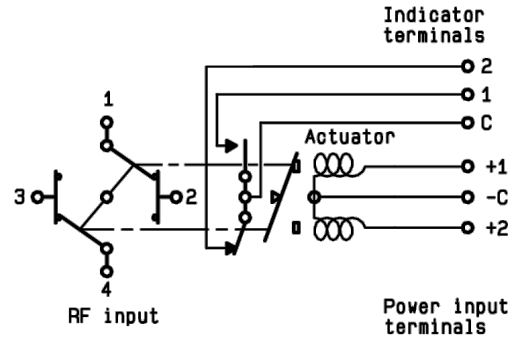

#### WITH SUPPRESSION DIODES

R577-3-030

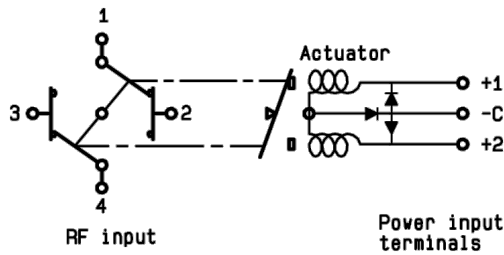

#### WITH SUPPRESSION DIODES & INDICATOR CONTACT

R577-4-030

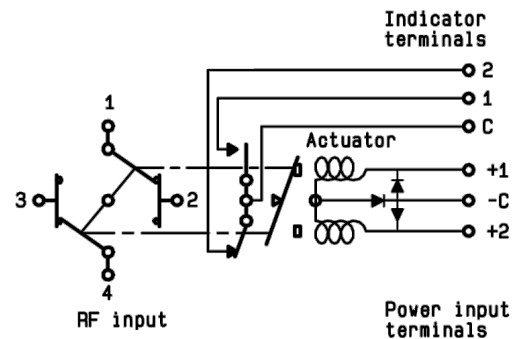

#### WITH TTL DRIVER (SUPPRESSION DIODES ARE INCLUDED)

R577-3-100

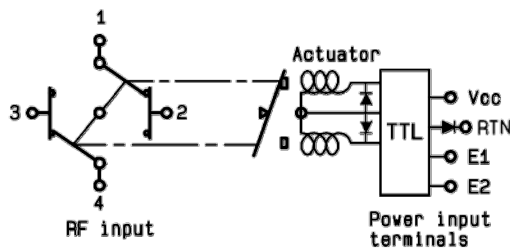

#### WITH TTL DRIVER & INDICATOR CONTACT

(SUPPRESSION DIODES ARE INCLUDED)

R577-4-100

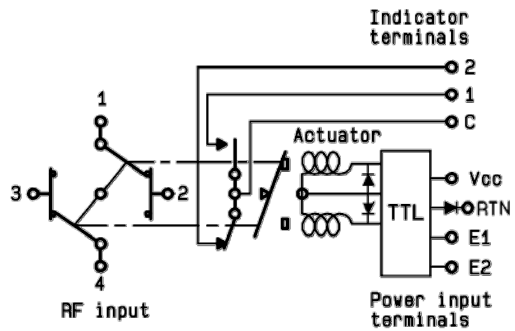

### COAXIAL DPDT (CONTINUED)

#### R577 SERIES

#### LATCHING

WITH CUT-OFF (SUPPRESSION DIODES ARE INCLUDED)  
R577-5-000

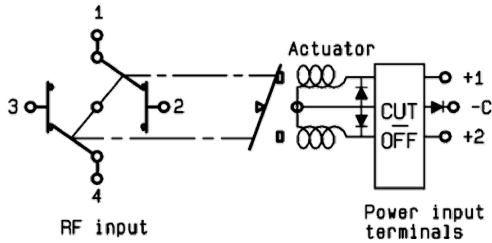

WITH CUT-OFF & INDICATOR CONTACT  
(SUPPRESSION DIODES ARE INCLUDED)  
R577-6-000

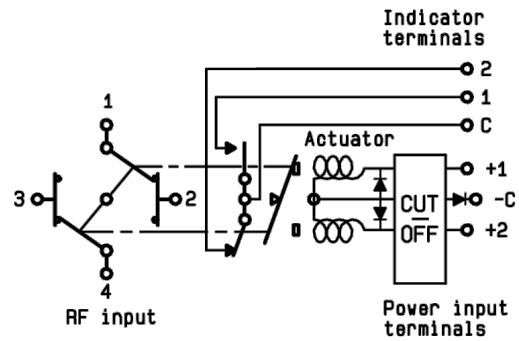

WITH CUT-OFF & TTL DRIVER  
R577-5-100

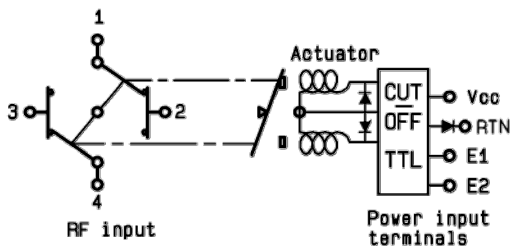

WITH CUT-OFF & INDICATOR CONTACT  
(SUPPRESSION DIODES ARE INCLUDED)  
R577-6-100

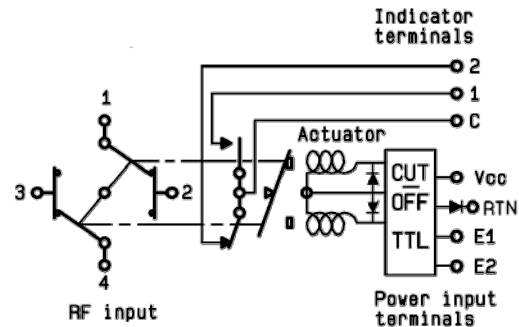

WITH POSITIVE COMMON, NO OPTION  
R577-3-010

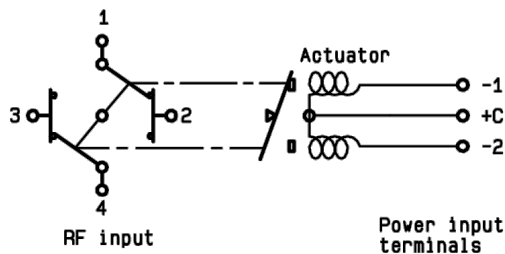

WITH POSITIVE COMMON & INDICATOR CONTACT  
R577-4-010

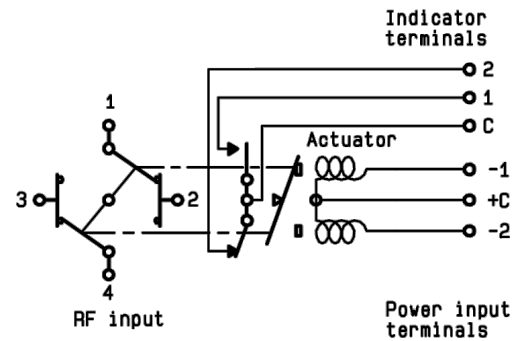

## COAXIAL DPDT (CONTINUED)

### R577 SERIES

#### LATCHING

WITH POSITIVE COMMON & SUPPRESSION DIODES  
R577-3-040

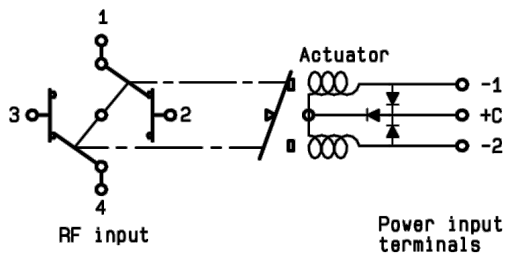

WITH POSITIVE COMMON, SUPPRESSION DIODES & INDICATOR CONTACT  
R577-4-040

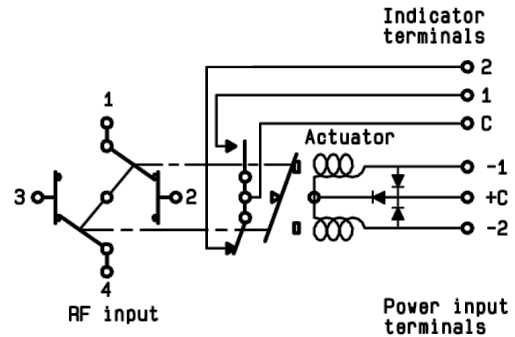

WITH POSITIVE COMMON & CUT-OFF  
(SUPPRESSION DIODES ARE INCLUDED)  
R577-5-010

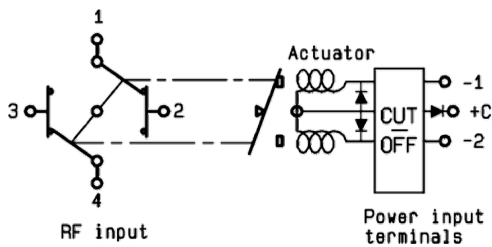

WITH POSITIVE COMMON, CUT-OFF & INDICATOR CONTACT  
(SUPPRESSION DIODES ARE INCLUDED)  
R577-6-010

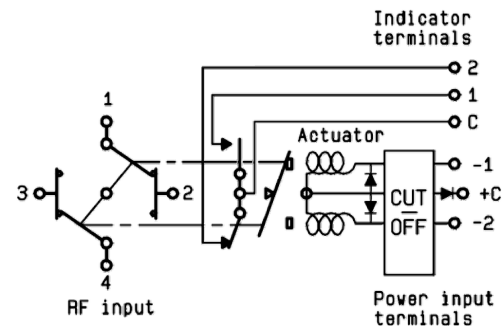

#### PIN IDENTIFICATION

TYPE	PIN						
	1	2	3	4	6	7	8
Failsafe	+		-				
Failsafe + I.C.	+		-		1	2	C
Failsafe + TTL	E		RTN	VCC			
Failsafe + I.C. + TTL	E		RTN	VCC	1	2	C
Latching	-1 or +1	-2 or +2	+C or -C				
Latching + I.C.	-1 or +1	-2 or +2	+C or -C		1	2	C
Latching + Cut-off							
Latching + I.C. + Cut-off							
Latching + Cut-off Latching + Cut-off + I.C.	E2	E1	RTN	VCC			
Latching + TTL + I.C.	E2	E1	RTN	VCC	1	2	C

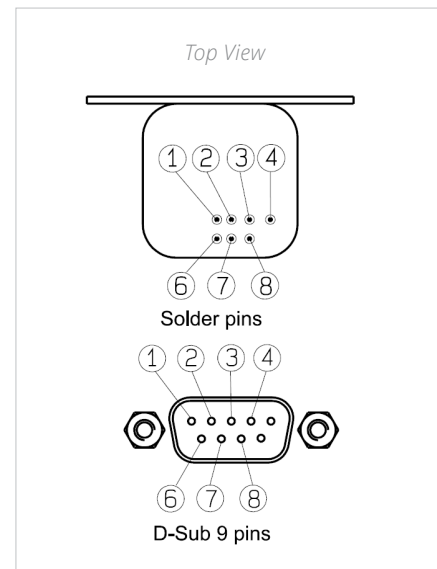

Titanium Series

**HIGH PERFORMANCE DPDT**

**DPDT UP TO 40 GHz**



Radiall's TITANIUM series switches are optimized to perform at a high level over an extended life cycle. With outstanding RF performance, and a guaranteed insertion loss repeatability of 0.03 dB over a life span of 2.5 million switching cycles. Radiall's TITANIUM switches are perfect for automated test and measurement equipment, as well as signal monitoring devices.

*Example of P/N: R513473148 is a DPDT SMA 20 GHz, latching, Self Cut-Off, diodes, positive common, TTL driver, Indicators, HE10 receptacle with bracket.*

**PART NUMBER SELECTION**

**R513**

**SERIES PREFIX**

**RF CONNECTORS**

- 3: SMA up to 6 GHz
- 4: SMA up to 20 GHz
- F: SMA up to 26.5 GHz
- 8: SMA2.9 up to 40 GHz <sup>[2]</sup>

**TYPE**

- 7: Latching + Self cut-off + Indicators

**ACTUATOR VOLTAGE**

- 3: 24 Vdc

**TTL OPTION**

- 1: With TTL driver

**OPTIONS**

- 4: With suppression diodes and positive common

**ACTUATOR TERMINALS & FIXING**

- 8: HE 10 receptacle with bracket <sup>[1]</sup>
- 9: HE 10 receptacle without bracket <sup>[1]</sup>

**DOCUMENTATION**

- : Certificate of conformity
- C: Calibration certificate
- R: Calibration certificate + RF curves

**Notes**

1. Delivered with 750 mm (30 inches) ribbon cable + HE10 connector.
2. Connector SMA2.9 is equivalent to "K connector<sup>®</sup>" registered trademark of Anritsu.

## Titanium Series

## GENERAL SPECIFICATIONS

OPERATING MODE		LATCHING	
Nominal operating voltage (across operating temperature)	Vdc	24 (20/32)	
Coil resistance (+/-10%)	$\Omega$	120	
Nominal operating current at 23 °C	mA	200	
Maximum stand-by current	mA	50	
Average power		RF path Cold switching: see RF Power Rating Chart on page 4-19 Hot switching: 1 Watt CW	
TTL input	High Level	3 to 7 V	1.4 mA max at 7 V
	Low Level	0 to 0.8 Volts	-
Indicator specifications		Maximum withstanding voltage	60 V
		Maximum current capacity	150 mA
		Maximum "ON" resistance	2.5 $\Omega$
		Minimum "OFF" resistance	100 M $\Omega$
Switching time (max)	ms	15	
Life (min)		2.5 million cycles	
Connectors		SMA - SMA 2.9	
Actuator terminals		HE10 ribbon receptacle	
Weight (Max)	g	110	

## ENVIRONMENTAL SPECIFICATIONS

Operating temperature range	-25°C to +75°C
Storage temperature range	-55°C to +85°C
Temperature cycling (MIL-STD-202, Method 107D, Cond.A)	-55°C to +85°C (10 cycles)
Vibration (MIL STD 202, Method 204D, Cond.D) operating	10 - 2,000 Hz, 10 g
Shock (MIL STD 202, Method 213B, Cond.C) operating	50 g / 6 ms, 1/2 sine
Moisture resistance (MIL STD 202, Method 106E, Cond.E)	65°C, 95% RH, 10 days
Altitude storage (MIL STD 202, Method 105C, Cond.B)	50,000 ft (15,240 meters)
RFI (MIL STD 1344, Method 3008 or IEC 61726)	40 dB at 20 GHz

Titanium Series

RF PERFORMANCE

PART NUMBER		R51337314-	R51347314-		R513F7314-		R51387314-		
Frequency Range	GHz	DC to 6	DC to 20		DC to 26.5		DC to 40		
Impedance	Ω	50							
Insertion Loss (max)	dB	0.2 + 0.025 × frequency (GHz)							
Isolation (min)	dB	80	DC to 6 GHz 6 to 12.4 GHz 12.4 to 20 GHz	80 70 65	DC to 6 GHz 6 to 12.4 GHz 12.4 to 20 GHz 20 to 26.5 GHz	80 70 65 60	DC to 6 GHz 6 to 12.4 GHz 12.4 to 20 GHz 20 to 26.5 GHz 26.5 to 40 GHz	80 70 65 60 55	
V.S.W.R. (max)		1.20	DC to 6 GHz 6 to 12.4 GHz 12.4 to 20 GHz	1.20 1.25 1.40	DC to 6 GHz 6 to 12.4 GHz 12.4 to 20 GHz 20 to 26.5 GHz	1.20 1.25 1.40 1.65	DC to 6 GHz 6 to 12.4 GHz 12.4 to 20 GHz 20 to 26.5 GHz 26.5 to 40 GHz	1.20 1.25 1.40 1.65 1.70	
Repeatability (at 25 °C)		0.03 dB					0.05 dB		

TYPICAL RF PERFORMANCE

INSERTION LOSS & ISOLATION

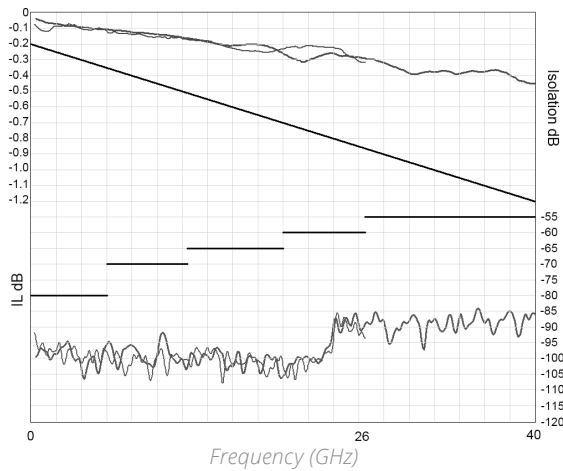

V.S.W.R.

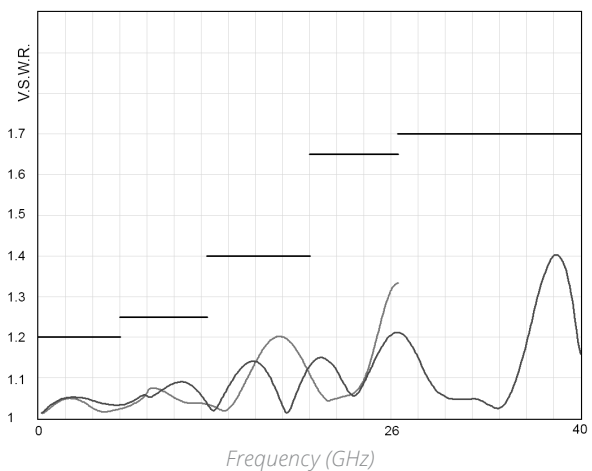

SMA — SMA 2.9 —

Titanium Series

**DRIVING THE SWITCH**

Transfer switches are configured with two positions. Each RF path can be closed by applying ground or TTL "High" to the corresponding "driver " pin.

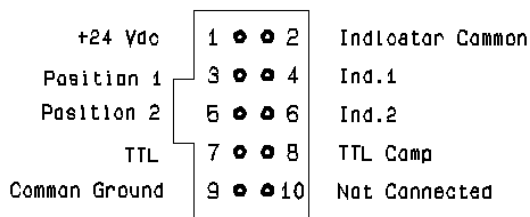

Switch connector

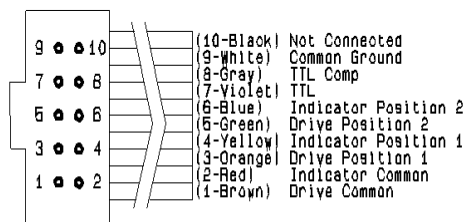

Mating cable connector

**Standard Drive**

- Connect pin 9 to ground (See note)
- Connect pin 1 to supply (+20 VDC to +32 VDC)
- Select (close) desired RF paths by applying ground to the corresponding "drive" pin (Ex: apply ground to pin 3 to close RF path 1-2 and 3-4)
- To select the second path, ensure that the unwanted RF path "drive" pin is disconnected from ground. Apply ground to the "drive" pin which corresponds to the desired RF paths (Ex: apply ground to pin 5 to close RF path 1-3 and 2-4)

**TTL Drive (Dual line)**

- Connect pin 9 to ground
- Connect pin 1 to supply (+20 VDC to +32 VDC)
- Select (close) desired RF path by applying TTL "High" to the corresponding "drive" pin (Ex: apply TTL "High" to pin 7 and TTL "Low" to pin 8 to close RF paths position 1)
- To select the second path, ensure that the unwanted RF path "drive" pins are in TTL "Low" position. Apply TTL "High" to the "drive" pin which correspond to the desired RF path and TTL "low" to the undesired. (Ex: apply TTL "High" to pin 8 and TTL "Low" to pin 7 to close RF paths position 2)

**RF SCHEMATIC DIAGRAM**

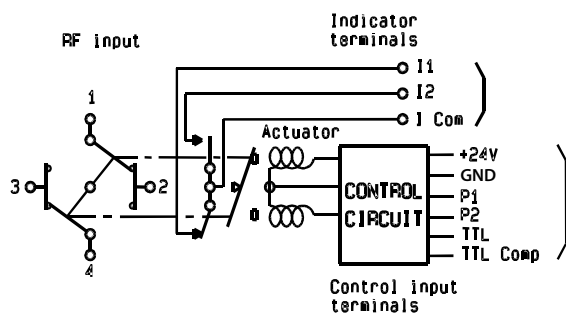

**TTL Drive (Single line)**

- Connect pin 9 to ground
- Connect pin 1 to supply (+20 VDC to +32 VDC)
- Connect pin 8 to TTL "High"
- Select (close) position 1 by applying TTL "High" to pin 7 (Ex: apply TTL "High" to pin 7 to close RF paths 1-2 and 3-4)
- Select position 2 by applying TTL "Low" to pin 7 (Ex: apply TTL "Low" to pin 7 to close RF paths 1-3 and 2-4)

	RF CONTINUITY	INDICATOR
Position 1	1-2 / 3-4	ICom - I1
Position 2	1-3 / 2-4	ICom - I2

**Notes**

Pin 9 does not need to be grounded for the switch to operate in standard drive. If pin 9 is not grounded, the position indicators will only function while the appropriate drive is applied. Therefore, if a pulse drive is used and continuous indicator operation is required, pin 9 must be grounded.

RF PERFORMANCE

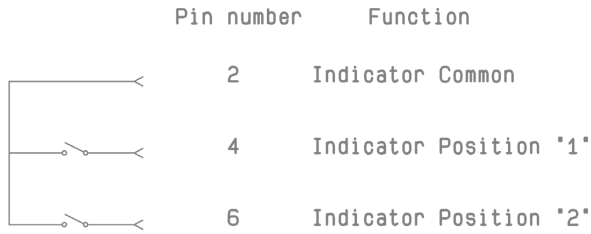

The electronic position indicators use photo-MOS transistors, which are driven by the mechanical position of the RF paths moving elements. The circuitry consists of a common which can be connected to an output corresponding to selected RF path. The photo-MOS transistors are configured for AC and/or DC operation. The electronic position indicators require the supply (20 to 32 VDC) to be connected to pin 1 and ground connected to pin 9.

TYPICAL OUTLINE DRAWING

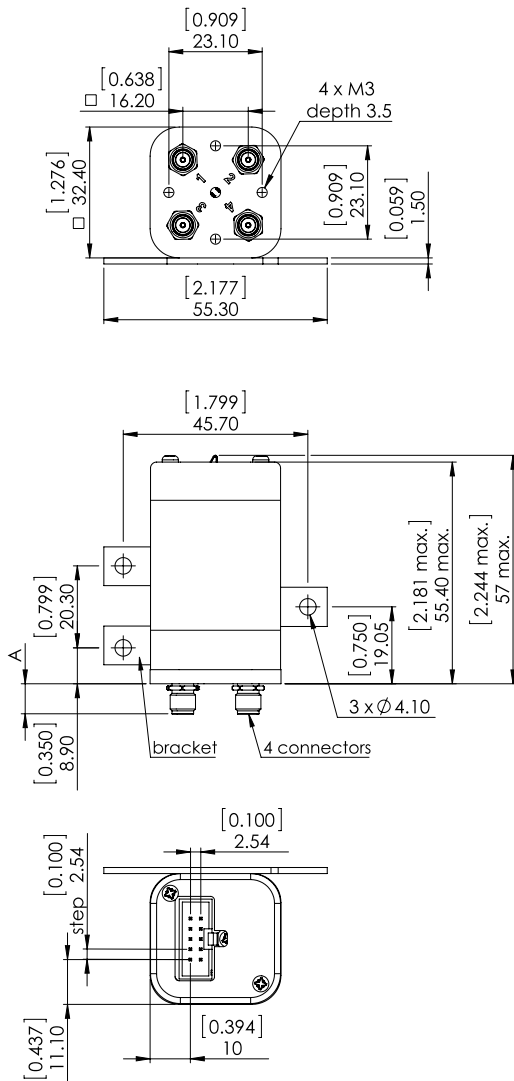

CONNECTORS	SMA	SMA 2.9
A max (mm [inches])	7.7 [0.303]	6.7 [0.264]

Notes

All dimensions are in millimeters [inches].



Titanium Series

**POWER RATING CHART**

This graph is based on the following conditions:

- Ambient temperature: +25 °C
- Sea level
- V.S.W.R.: 1 and cold switching

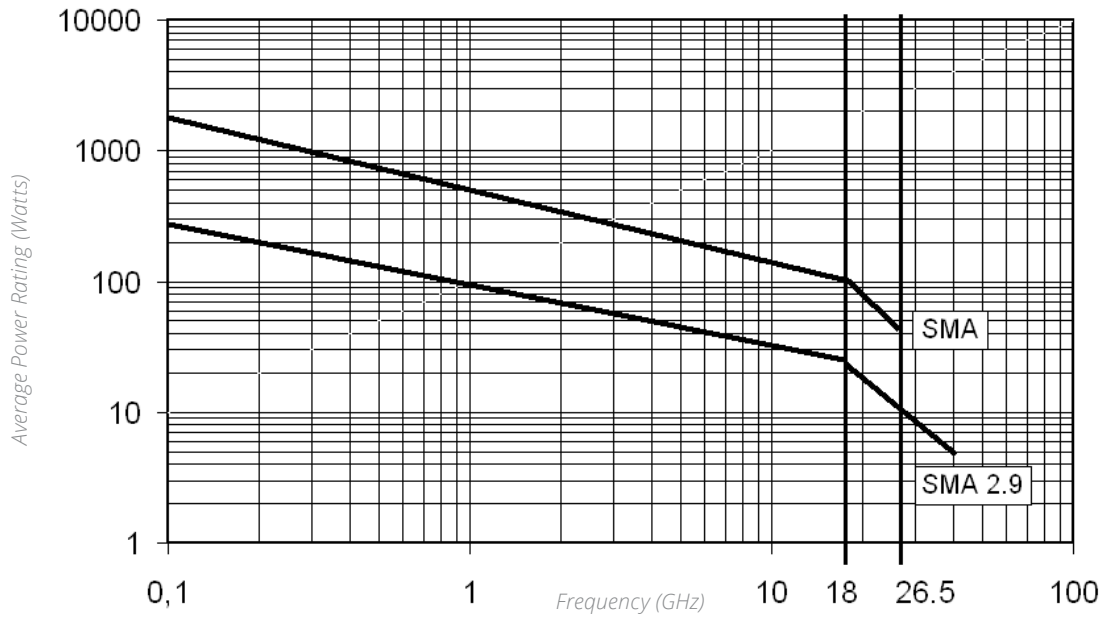

**DERATING FACTOR VERSUS V.S.W.R.**

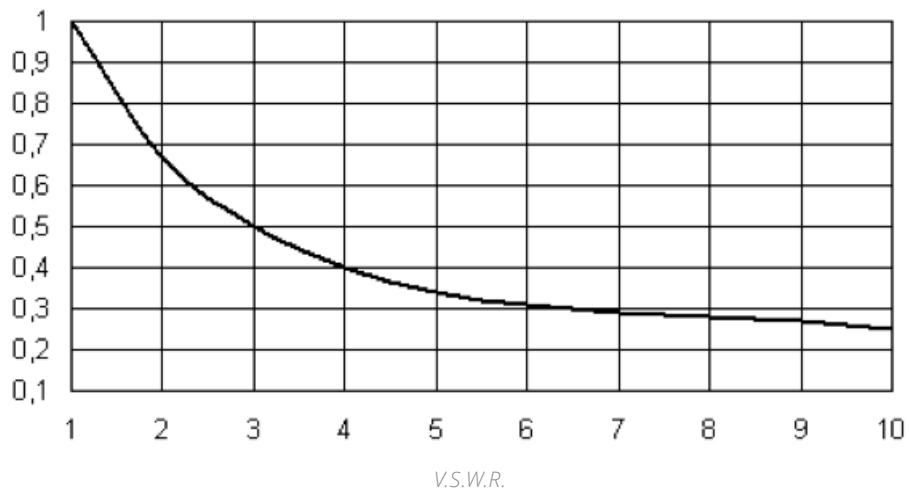

Platinum Series

**HIGH PERFORMANCE DPDT**

**DPDT UP TO 40 GHz**



Radiall's PLATINUM series switches are optimized to perform at a high level over an extended life cycle. With outstanding RF performance, and a guaranteed insertion loss repeatability of 0.03 dB over a life span of 10 million switching cycles. PLATINUM series switches are perfect for automated test and measurement equipment, as well as signal monitoring devices.

*Example of P/N: R593F73148 is a DPDT SMA 26.5 GHz, latching, Self Cut-Off, diodes, positive common, TTL driver, Indicators, HE10 receptacle with bracket.*

**PART NUMBER SELECTION**

**R593**

**SERIES PREFIX**

**RF CONNECTORS**

- 3: SMA up to 6 GHz
- 4: SMA up to 20 GHz
- F: SMA up to 26.5 GHz
- 8: SMA2.9 up to 40 GHz <sup>[2]</sup>

**TYPE**

- 7: Latching + Self cut-off + Indicators

**ACTUATOR VOLTAGE**

- 3: 24 Vdc

**TTL OPTION**

- 1: With TTL driver

**OPTIONS**

- 4: With suppression diodes and positive common

**ACTUATOR TERMINALS AND FIXING**

- 8: HE 10 receptacle with bracket <sup>[1]</sup>
- 9: HE 10 receptacle without bracket <sup>[1]</sup>

**DOCUMENTATION**

- : Certificate of conformity
- C: Calibration certificate
- R: Calibration certificate + RF curves

**Notes**

1. Delivered with 750 mm (30 inches) ribbon cable + HE10 connector.
2. Connector SMA2.9 is equivalent to "K connector" registered trademark of Anritsu.

## Platinum Series

## GENERAL SPECIFICATIONS

OPERATING MODE		LATCHING	
Nominal operating voltage (across operating temperature)	Vdc	24 (20/32)	
Coil resistance (+/-10%)	$\Omega$	120	
Nominal operating current at 23 °C	mA	200	
Maximum stand-by current	mA	50	
Average power		RF path Cold switching: see RF Power Rating Chart on page 4-25 Hot switching: 1 Watt CW	
TTL input	High Level	3 to 7 V	1.4 mA max at 7 V
	Low Level	0 to 0.8 Volts	-
Indicator specifications		Maximum withstanding voltage	60 V
		Maximum current capacity	150 mA
		Maximum "ON" resistance	2.5 $\Omega$
		Minimum "OFF" resistance	100 M $\Omega$
Switching time (max)	ms	15	
life (min)	SMA	10 million cycles	
	SMA 2.9	5 million cycles	
Connectors		SMA - SMA 2.9	
Actuator terminals		HE10 ribbon receptacle	
Weight (Max)	g	110	

## ENVIRONMENTAL SPECIFICATIONS

Operating temperature range	-25°C to +75°C
Storage temperature range	-55°C to +85°C
Temperature cycling (MIL-STD-202, Method 107D, Cond.A)	-55°C to +85°C (10 cycles)
Vibration (MIL STD 202, Method 204D, Cond.D) operating	10 - 2,000 Hz, 10 g
Shock (MIL STD 202, Method 213B, Cond.C) operating	50 g / 6 ms, 1/2 sine
Moisture resistance (MIL STD 202, Method 106E, Cond.E)	65°C, 95% RH, 10 days
Altitude storage (MIL STD 202, Method 105C, Cond.B)	50,000 ft (15,240 meters)
RFI (MIL STD 1344, Method 3008 or IEC 61726)	40 dB at 20 GHz

Platinum Series

RF PERFORMANCE

PART NUMBER		R59337314-	R59347314-	R593F7314-		R59387314-	R51387314-	
Frequency Range	GHz	DC to 6	DC to 20		DC to 26.5		DC to 40	
Impedance	Ω	50						
Insertion Loss (max)	dB	0.2 + 0.025 × frequency (GHz)						
Isolation (min)	dB	100	DC to 6 GHz 6 to 12.4 GHz 12.4 to 20 GHz	100 90 80	DC to 6 GHz 6 to 12.4 GHz 12.4 to 20 GHz 20 to 26.5 GHz	100 90 80 65	DC to 6 GHz 6 to 12.4 GHz 12.4 to 20 GHz 20 to 26.5 GHz 26.5 to 40 GHz	100 90 80 65 60
V.S.W.R. (max)		1.20	DC to 6 GHz 6 to 12.4 GHz 12.4 to 20 GHz	1.20 1.25 1.40	DC to 6 GHz 6 to 12.4 GHz 12.4 to 20 GHz 20 to 26.5 GHz	1.20 1.25 1.40 1.65	DC to 6 GHz 6 to 12.4 GHz 12.4 to 20 GHz 20 to 26.5 GHz 26.5 to 40 GHz	1.20 1.25 1.40 1.65 1.70
Repeatability (at 25 °C)		0.03 dB					0.05 dB	

TYPICAL RF PERFORMANCE

INSERTION LOSS & ISOLATION

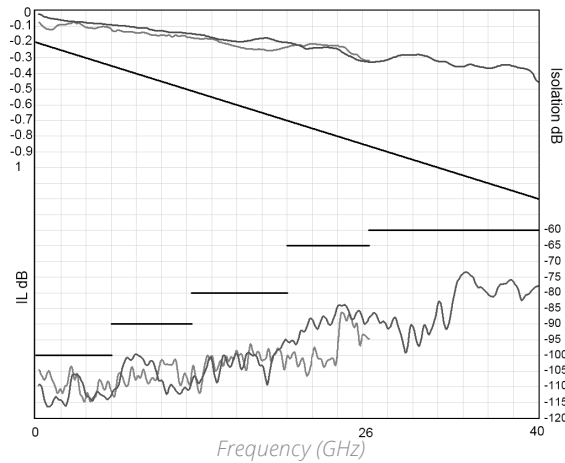

SMA — SMA 2.9 —

V.S.W.R.

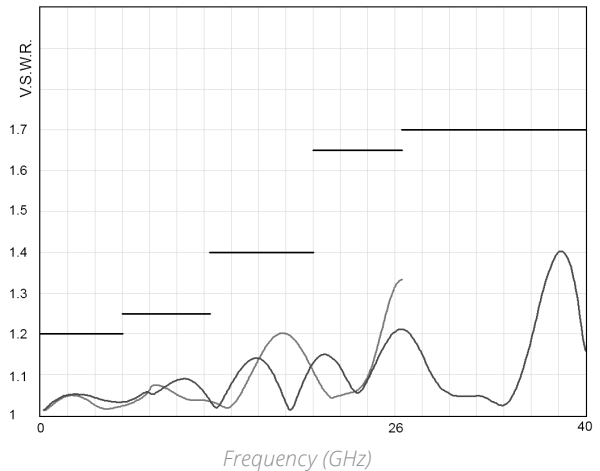

Platinum Series

DRIVING THE SWITCH

Transfer switches are configured with two positions. Each RF path can be closed by applying Ground or TTL "High" to the corresponding "driver " pin.

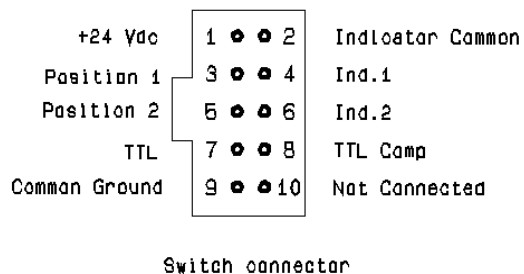

Standard Drive

- Connect pin 9 to ground (See note)
- Connect pin 1 to supply (+20 VDC to +32 VDC)
- Select (close) desired RF paths by applying ground to the corresponding "drive" pin (Ex: apply ground to pin 3 to close RF path 1-2 and 3-4)
- To select the second path, ensure that the unwanted RF path "drive" pin is disconnected from ground. Apply ground to the "drive" pin which corresponds to the desired RF paths (Ex: apply ground to pin 5 to close RF path 1-3 and 2-4)

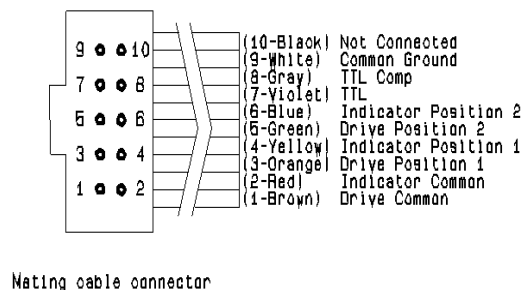

TTL Drive (Dual line)

- Connect pin 9 to ground
- Connect pin 1 to supply (+20 VDC to +32 VDC).
- Select (close) desired RF path by applying TTL "High" to the corresponding "drive" pin (Ex: apply TTL "High" to pin 7 and TTL "Low" to pin 8 to close RF paths position 1)
- To select the second path, ensure that the unwanted RF path "drive" pins are in TTL "Low" position. Apply TTL "High" to the "drive" pin which corresponds to the desired RF path and TTL "low" to the undesired (Ex: apply TTL "High" to pin 8 and TTL "Low" to pin 7 to close RF paths position 2)

RF SCHEMATIC DIAGRAM

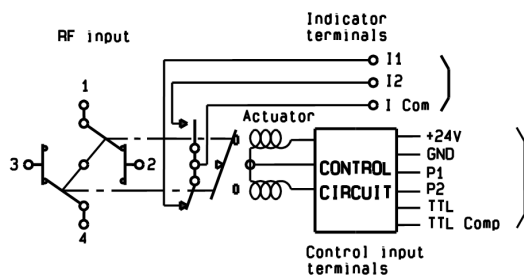

TTL Drive (Single line)

- Connect pin 9 to ground
- Connect pin 1 to supply (+20 VDC to +32 VDC)
- Connect pin 8 to TTL "High"
- Select (close) position 1 by applying TTL "High" to pin 7 (Ex: apply TTL "High" to pin 7 to close RF paths 1-2 and 3-4)
- Select position 2 by applying TTL "Low" to pin 7 (Ex: apply TTL "Low" to pin 7 to close RF paths 1-3 and 2-4)

	RF CONTINUITY	INDICATOR
Position 1	1-2 / 3-4	ICom - I1
Position 2	1-3 / 2-4	ICom - I2

Notes

Pin 9 does not need to be grounded for the switch to operate in standard drive. If pin 9 is not grounded, the position indicators will only function while the appropriate drive is applied. Therefore, if a pulse drive is used and continuous indicator operation is required, pin 9 must be grounded.

RF PERFORMANCE

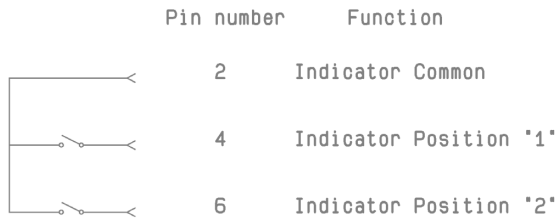

The electronic position indicators use photo-MOS transistors, which are driven by the mechanical position of the RF paths moving elements. The circuitry consists of a common which can be connected to an output corresponding to selected RF path. The photo-MOS transistors are configured for AC and/or DC operation.

The electronic position indicators require the supply (20 to 32 VDC) to be connected to pin 1 and ground connected to pin 9.

TYPICAL OUTLINE DRAWING

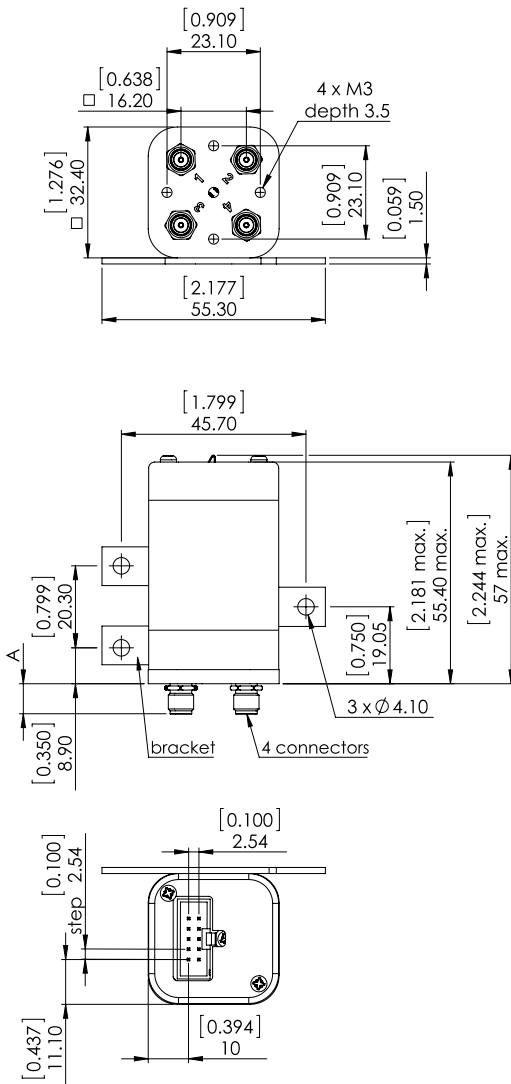

CONNECTORS	SMA	SMA2.9
A max (mm [inches])	7.7 [0.303]	6.7 [0.264]

Notes

All dimensions are in millimeters [inches].

Platinum Series

**POWER RATING CHART**

This graph is based on the following conditions:

- Ambient temperature: +25 °C
- Sea level
- V.S.W.R.: 1 and cold switching

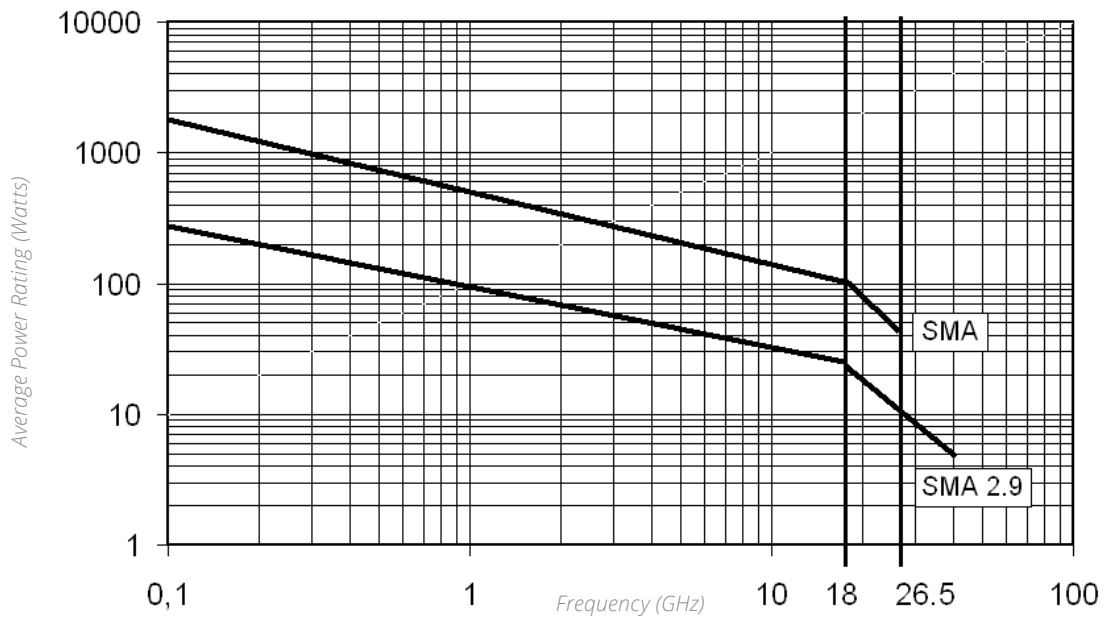

**DERATING FACTOR VERSUS V.S.W.R.**

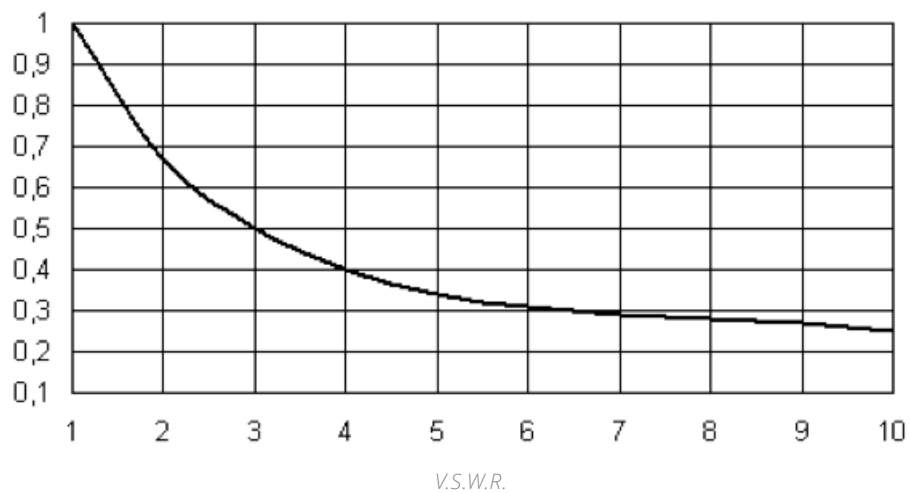

Optional Features

**OPTIONAL FEATURES FOR DPDT SWITCHES**

**GENERAL**

A microwave circuit or component can be inserted into a transmission line by using a DPDT switch as a bypass product. In event that the short-circuit of the microwave circuit or component is undesirable, the J1/J3 path can be left out (see application option below).

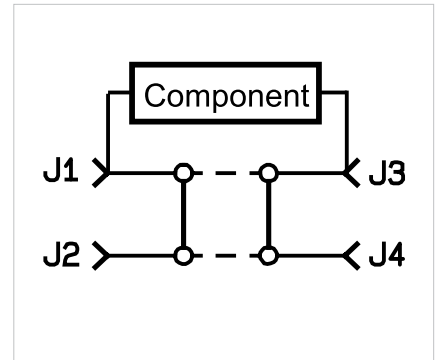

**EXAMPLES OF DEDICATED APPLICATION OPTIONS**

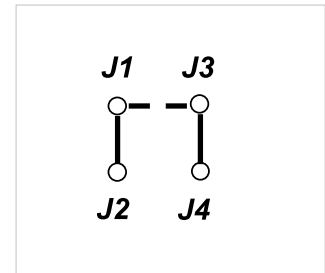
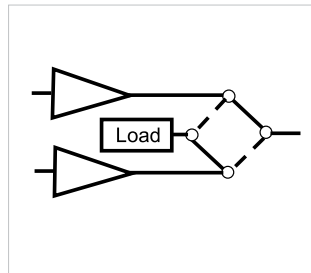

This DPDT with a cable load is used for redundancy purposes for 2 amplifiers, one working, the other one in stand-by.

This true Bypass Switch is based on a DPDT with only 3 RF ways instead of 4.

- Component inserted in J2/J4
- POS 1: J1 to J3: Direct line
- POS 2: J1 to J3: Component line



This DPDT has been fitted with a specific bracket to fulfill a specific customer request.



This DPDT was designed with a specific flat cable for an easy integration.





# SPnT

---



Section 5 Table of Contents

**SUBMINIATURE SERIES**

SPnT up to 40 GHz: R591 Series ..... 5-2 to 5-4  
 R591 Series Electrical Schematics.....5-5 to 5-7

**USB SERIES**

SPnT USB up to 40 GHz: R57xxxx01 Series  
 (Terminated and Non-Terminated).....5-8 to 5-13

**RAMSES SERIES**

SPnT up to 50 GHz: R57x Series  
 (Terminated and Non-Terminated).....5-14 to 5-25  
 SPnT up to 12.4 GHz: R57x Series  
 (N, BNC and TNC models) ..... 5-26 to 5-30  
 RF Connector Allocation for SPnT Series ..... 5-31 to 5-32

**ACCESSORIES SPNT & ELECTRICAL SCHEMATICS**

Coaxial SPnT - Accessories..... 5-33 to 5-37  
 Coaxial SPnT - Electrical Schematics..... 5-38 to 5-43

**TITANIUM SERIES**

High Performance Multiport Switches  
 SPnT up to 40GHz: R51x Series.....5-44 to 5-50

**PLATINUM SERIES**

High Performance Multiport Switches - SPnT Terminated  
 Up to 40 GHz: R594 Series ..... 5-52 to 5-58

**OPTIONAL FEATURES**

Optional Features ..... 5-59

**SPNT PART NUMBER SELECTION GUIDE<sup>[1]</sup>**

PLATINUM SPnT	TITANIUM SPnT	RAMSES		USB SPnT	SUBMIN. SPnT	Series Configuration	DIGITAL POSITION
		R57	SPnT				
R594	R51	R57	SPnT	R57	R591	-	R 1-3/ MODEL:
-	2	3	3	3	-	Not terminated	4: RF CONNECTORS
-	4	4	4	4	-	Terminated	
3	3	-	-	-	-	SMA 3 GHz	
-	-	-	-	-	3	SMA 6 GHz	
4	4	-	-	-	-	SMA 18 GHz	
F	F	-	-	-	-	SMA 20 GHz	
8	8	-	-	F	7	SMA 26.5 GHz	
-	-	-	-	8	8	SMA 2.9 40 GHz	
-	-	-	-	-	-	2.4mm 50 GHz	
-	-	-	-	-	E	QMA 6 GHz	
-	-	-	-	-	-	DIN 1.6/5.6/2.5 GHz	
-	-	0	-	-	-	N 3 GHz	
-	-	1	-	-	-	N 12.4 GHz	
-	-	2	-	-	-	BNC 3 GHz	
-	-	5	-	-	-	TNC 3 GHz	
-	-	6	-	-	-	TNC 12.4 GHz	
-	-	0/1	0/1	1	0	Normally open	
4/7	7	2/3/4/5/8/9	2/3/4/5/8/9	-	2/6	Latching	
-	-	-	-	1	-	5 V	
-	-	2	2	-	2	12 V	
3	3	-	-	-	-	24 V	
-	-	3	3	-	3	28 V	
4/6	4/6	3-12	3-12	6/8	4/6	Number of positions	
-	-	0	0	0	0	Without option	
1	1	1	1	-	1	Positive common	
2	2	2	2	-	2	TTL driver	
-	-	3	3	-	3	Suppression diodes	
-	-	4	4	-	4	Positive common and suppression diodes	
-	-	8	8	-	-	BCD TTL driver compatible	
-	-	0	0	-	0	Solder pins	
-	-	5	5	-	-	D-Sub connector	
-	-	-	-	1	-	Mini USB	
-	-	-	-	-	5	Micro-D connector	
7	7	-	-	-	-	HE 10 receptacle	
-	-	-	-	-	-	Certificate of conformity	
C	C	-	-	-	-	Calibration certificate	
R	R	-	-	-	-	Calibration certificate + RF curves	
5: TYPE	6: VOLTAGE	7: POS.	8: OPTIONS	9: TERMINALS	10: DOCUMENTATION		

**Notes**

Example of P/N: R591703400 is a SP4T SMA up to 26.5 GHz, normally open, 28 Vdc, without option, solder pins.  
 1. For part number creation and available options, see detailed part number selection for each series.

## Subminiature Series

## SUBMINIATURE SPNT UP TO 40 GHz

## SMA – SMA 2.9 – QMA



Radiall's R591 coaxial subminiature switches have a typical operating life exceeding 25 million cycles; Providing excellent RF performance, repeatability, and a guaranteed life of 10 million cycles, which makes switches ideal for Automated Test Equipment (ATE) and other measurement applications. These subminiature switches are also an excellent choice for Mil/ Aero applications due to their small size, light weight, and outstanding shock and vibration handling capabilities.

Example of P/N: R591302420 is a SP4T SMA up to 6 GHz, normally open, 12 Vdc with TTL driver and solder pins.

## PART NUMBER SELECTION

## R591

## SERIES PREFIX

## RF CONNECTORS

- 3: SMA up to 6 GHz
- 7: SMA up to 26.5 GHz
- 8: SMA 2.9 up to 40 GHz <sup>[6]</sup>
- E: QMA up to 6 GHz <sup>[5]</sup>

## TYPE

- 0: Normally open
- 2: Latching, global reset
- 6: Latching, separated reset <sup>[1]</sup>

## ACTUATOR VOLTAGE

- 2: 12 Vdc
- 3: 28 Vdc

## NUMBER OF POSITIONS

- 4: 4 positions
- 6: 6 positions

## OPTIONS

- 0: Without option
- 1: Positive common
- 2: With TTL driver <sup>[2, 3 & 4]</sup>
- 3: With suppression diodes
- 4: With suppression diodes and positive common

## ACTUATOR TERMINALS

- 0: Solder pins
- 5: Micro-D connector

## Notes

1. Available with "solder pins" models only.
2. Polarity is not relevant to application for switches with TTL driver.
3. Suppression diodes are already included with TTL option.
4. Available with "normally open" models only.
5. The QLF trademark (Quick Lock Formula<sup>®</sup>) standard applies to QMA and QN series and guarantees the full intermateability between suppliers using this trademark. Using QLF certified connectors also guarantees the specified level of RF performance.
6. Connector SMA2.9 is equivalent to "K connector<sup>®</sup>", registered trademark of Anritsu.



## Subminiature Series

## GENERAL SPECIFICATIONS

OPERATING MODE		NORMALLY OPEN		LATCHING	
Nominal operating voltage (across operating temperature)	Vdc	12 (10.2 / 13)	28 (21 / 30)	12 (10.2 / 13)	28 (21 / 30)
Coil resistance (+/-10%)	Ω	48	250	60	285
Operating current at 23 °C	mA	250	110	200	98
Average power		See RF Power Rating Chart page 1-13			
TTL input	High Level	2.2 to 5.5 Volts		800 μA max 5.5 Volts	
	Low Level	0 to 0.8 Volts		20 μA max 0.8 Volts	
Switching time (max)	ms	10			
Life	SMA-QMA	10 million cycles			
	SMA 2.9	2 million cycles			
Connectors		SMA - QMA - SMA 2.9			
Actuator terminals		Solder Pins: double row connector for wrapping, soldering (250 °C max / 30 sec), or connecting to 2.54 mm pitch female connector. 9 pin micro-D receptacle M83513/07-A according to MIL-C-85513.			
Operating temperature range		-40 °C to +85 °C			
Storage temperature range		-55 °C to +85 °C			
Sine vibration (According to MIL STD 202, Method 204D, Cond. D)		10 - 2,000 Hz, 20 g - operating			
Random vibration (According to MIL STD 202, Method 214A, Profile I, Cond. F)		50 - 2,000 Hz, 20.71 g - operating			
Shock (According to MIL STD 202, Method 213B, Cond. C)		100 g / 6 ms, 1/2 sine - operating			

## RF PERFORMANCE

CONNECTORS	FREQUENCY RANGE GHz		V.S.W.R. (MAX)	INSERTION LOSS (MAX) dB	ISOLATION (MIN) dB	IMPEDANCE Ω
QMA / SMA	DC - 6	DC - 3	1.20	0.20	80	50
		3 - 6	1.30	0.30	70	
SMA	DC - 26-5	DC - 3	1.20	0.20	80	
		3 - 8	1.30	0.30	70	
		8 - 12.4	1.40	0.40	60	
		12.4 - 18	1.50	0.50	60	
		18 - 26.5	1.60	0.60	55	
SMA 2.9	DC - 40	DC - 3	1.20	0.20	80	
		3 - 8	1.30	0.30	70	
		8 - 12.4	1.40	0.40	60	
		12.4 - 18	1.50	0.50	60	
		18 - 26.5	1.70	0.70	55	
		26.5 - 40	2.20	1.10	45	

## Notes

See page 5-4 for typical RF performance.

TYPICAL RF PERFORMANCE

INSERTION LOSS & ISOLATION

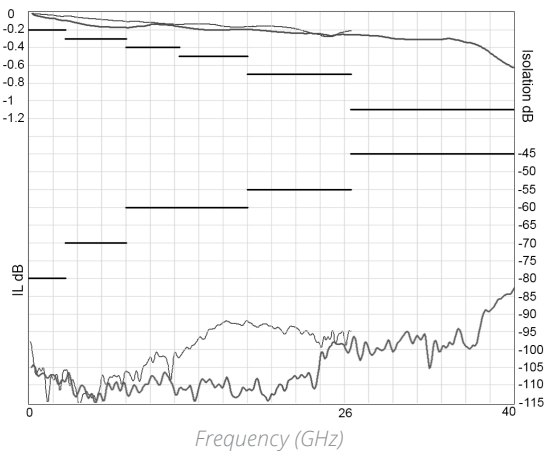

V.S.W.R

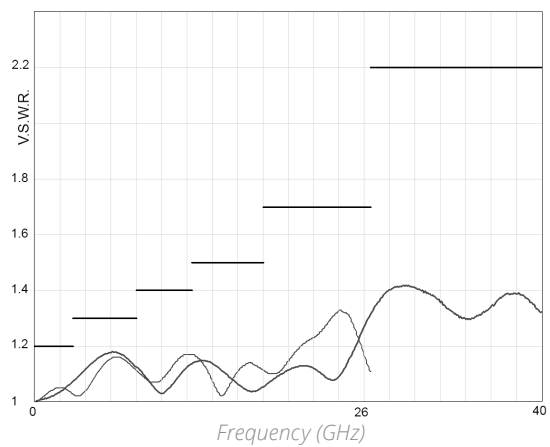

TYPICAL OUTLINE DRAWING <sup>[1]</sup>

SOLDER PIN MODEL

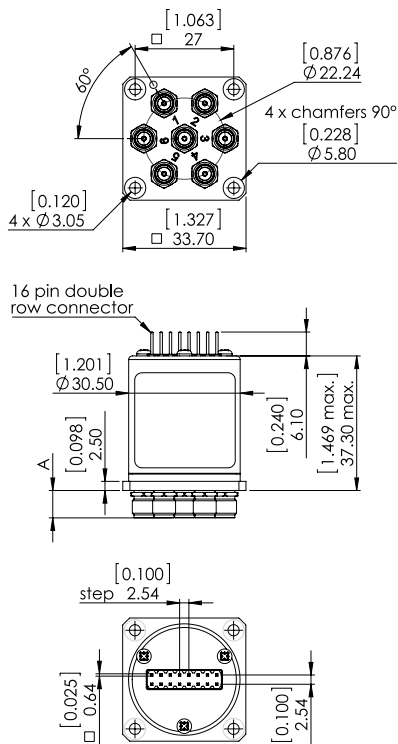

MICRO-D MODEL

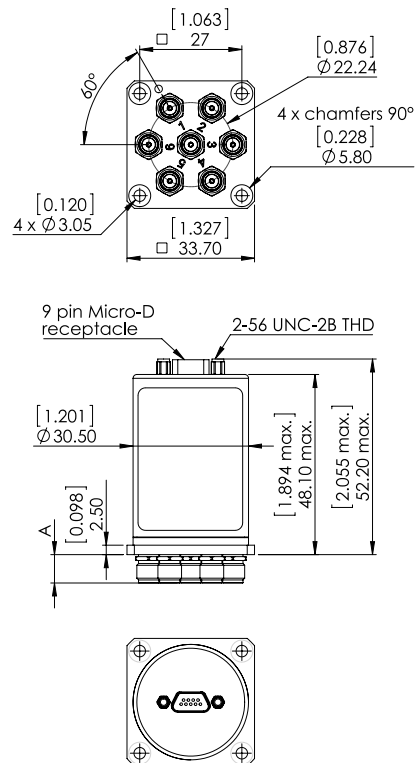

CONNECTORS	SMA	SMA 2.9	QMA
A max (mm/ [inches])	7.7 [0.303]	6.7 [0.264]	10.8 [0.394]

Notes

1. For SP4T, ways 3 and 6 not connected

2. All dimensions are in millimeters [inches].

## R591 SERIES ELECTRICAL SCHEMATICS

**NORMALLY OPEN WITHOUT OPTION**  
R591-0- -0-

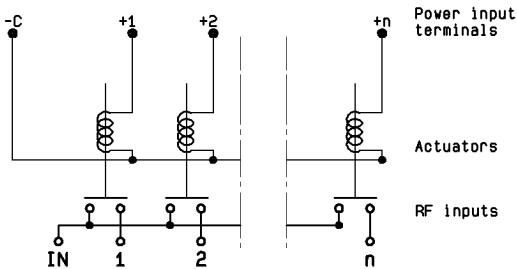

**NORMALLY OPEN WITH POSITIVE COMMON**  
R591-0- -1-

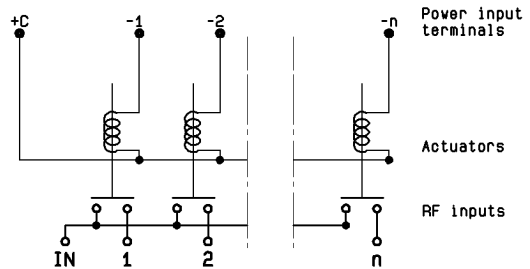

**NORMALLY OPEN WITH TTL DRIVE**  
R591-0- -2-

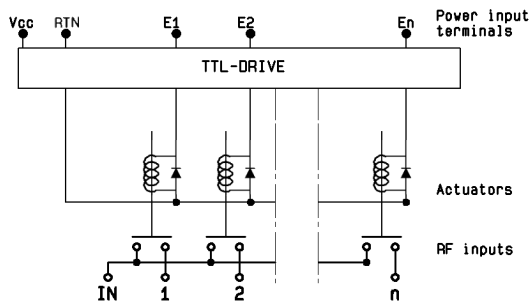

**NORMALLY OPEN WITH SUPPRESSION DIODES**  
R591-0- -3-

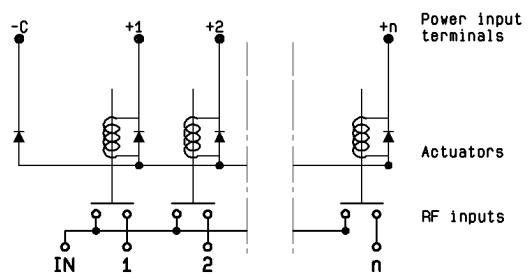

**NORMALLY OPEN WITH POSITIVE COMMON & SUPPRESSION DIODES**  
R591-0- -4-

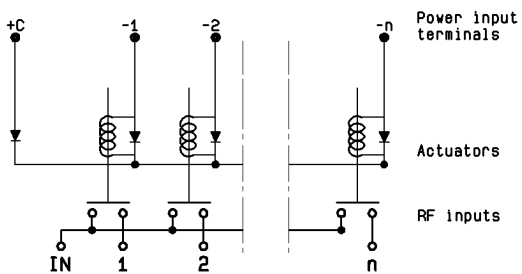

**LATCHING GLOBAL RESET WITHOUT OPTION**  
R591-2- -0-

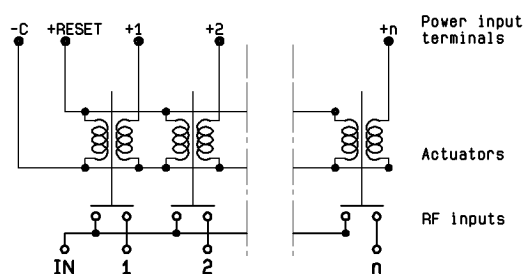

Subminiature Series

**LATCHING GLOBAL RESET WITH POSITIVE COMMON**  
R591-2--1-

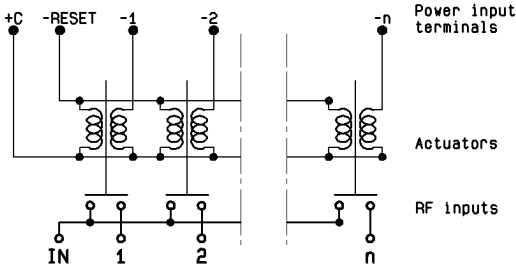

**LATCHING GLOBAL RESET WITH SUPPRESSION DIODES**  
R591-2--3-

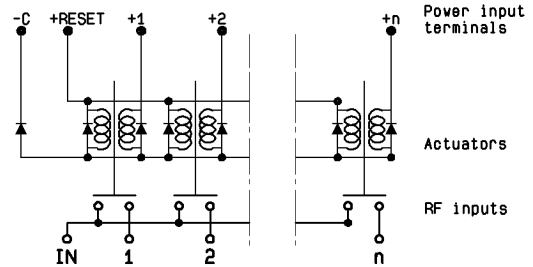

**LATCHING GLOBAL RESET WITH POSITIVE COMMON & SUPPRESSION DIODES**  
R591-2--4-

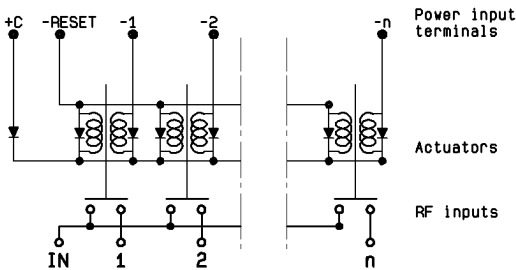

**LATCHING SEPARATED RESET WITHOUT OPTION**  
R591-6--0-

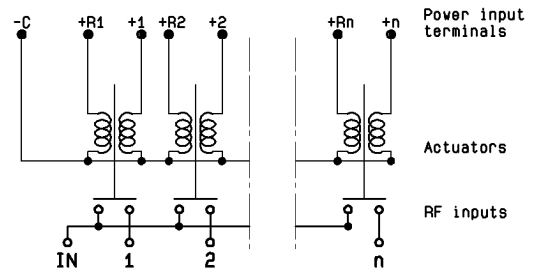

**LATCHING SEPARATED RESET WITH POSITIVE COMMON**  
R591-6--1-

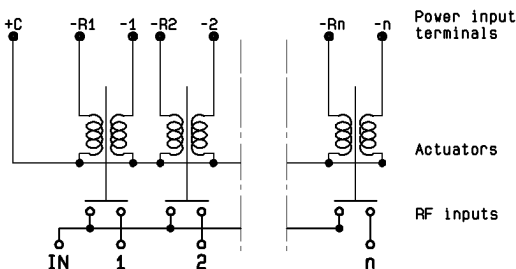

**LATCHING SEPARATED RESET WITH SUPPRESSION DIODES**  
R591-6--3-

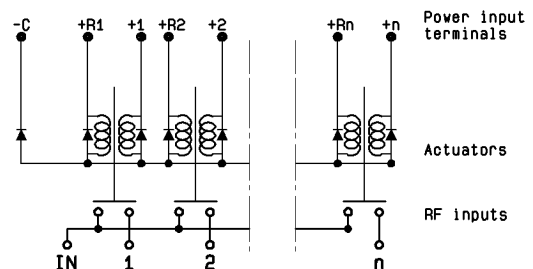



Subminiature Series

**LATCHING SEPARATED RESET WITH POSITIVE COMMON & SUPPRESSION DIODES**  
R591-6 -4-

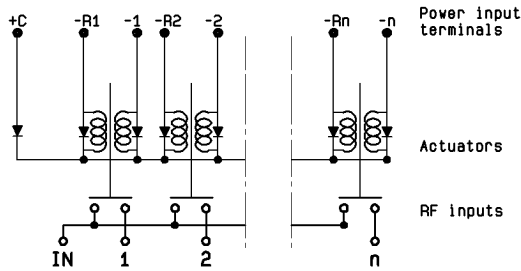

**PIN IDENTIFICATION**

**SOLDER PINS (TOP VIEW) <sup>[1]</sup>**

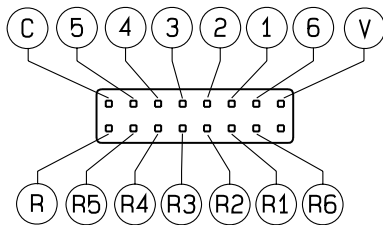

**9 PIN MICRO-D (TOP VIEW)**

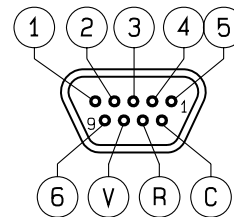

- 16 contact female connector
- NC: not connected
- For SP4T, ways 3 and 6 not connected
- Pin R = reset of all paths

TYPE		C	V	1	2	3	4	5	6	R	R1	R2	R3	R4	R5	R6
Normally open	Negative common	-C	NC	+1	+2	+3	+4	+5	+6	NC	NC	NC	NC	NC	NC	NC
	Positive common	+C	NC	-1	-2	-3	-4	-5	-6	NC	NC	NC	NC	NC	NC	NC
Latching global reset	Negative common	-C	NC	+1	+2	+3	+4	+5	+6	+reset	NC	NC	NC	NC	NC	NC
	Positive common	+C	NC	-1	-2	-3	-4	-5	-6	-reset	NC	NC	NC	NC	NC	NC
Latching individual reset <sup>[2]</sup>	Negative common	-C	NC	+1	+2	+3	+4	+5	+6	NC	+res.1	+res.2	+res.3	+res.4	+res.5	+res.6
	Positive common	+C	NC	-1	-2	-3	-4	-5	-6	NC	-res.1	-res.2	-res.3	-res.4	-res.5	-res.6
Normally open with TTL drive	-	RTN	VCC	E1	E2	E3	E4	E5	E6	NC	NC	NC	NC	NC	NC	NC

**Notes**

1. Compatible with 2.54 mm pitch double row and HE10 connector.
2. Available with "solder pins" models only.

**SPNT USB UP TO 40 GHz**  
**SMA – SMA 2.9**



Utilizing Radiall’s proven and patented RAMSES concept, our team of experts and engineers integrated a mini-USB terminal on SP6T and SP8T switches for simplified use especially in test & lab applications.

Featuring an easy-to-integrate design, USB Coaxial Switches are delivered with a 1 meter long USB cable for power supply and switch drive. A soft front panel is provided to control the switches but commonly used software programming platforms such as Visual Basic, C#, C++, LabVIEW and VEE are also compatible.

*Example of P/N: R573F11601 is a non-terminated SP6T SMA up to 26.5 GHz, Normally Open, 5 Vdc, Indicators with a mini USB port.*

**PART NUMBER SELECTION**

**R57                    1 1                    0 1**

**SERIES PREFIX** \_\_\_\_\_

**MODEL** \_\_\_\_\_

**3:** Without 50 Ω termination

**4:** With 50 Ω termination

**RF CONNECTORS** \_\_\_\_\_

**F:** SMA up to 26.5 GHz

**8:** SMA 2.9 up to 40 GHz <sup>[1 & 2]</sup>

**TYPE** \_\_\_\_\_

**1:** Normally open I. + C.

**ACTUATOR VOLTAGE** \_\_\_\_\_

**1:** 5 Vdc

**NUMBER OF POSITIONS** \_\_\_\_\_

**6:** 6 positions

**8:** 8 positions

**OPTIONS** \_\_\_\_\_

**0:** Without option

**ACTUATOR TERMINALS** \_\_\_\_\_

**1:** Mini USB socket

**Notes**

*I.C.:* Indicator contact

1. Available only with 6 positions.

2. Connector SMA 2.9 is equivalent to "K connector®", registered trademark of Anritsu.

**APPLICATION NOTE**

*USB coaxial switch as cascade*

You can use as many USB switches in cascade as you want. Each product is recognized by its automatic affectation to the ComPort and in order to differentiate them, each product has its own serial number which can be read by the software.

In order to provide power supply (5V / 420mA) and drive as many switches as you want with your computer, you will need a hub USB which can provide same power as a classic USB port of the computer (500mA / 5V) or a PCI expansion card USB (if it is a desktop).

**APPLICATION EXAMPLE**

**BEFORE**



*DC power from a power supply and wires to provide power to PF Paths*



**AFTER**



*USB Cable mini B to Type A*



*Control with computer*

**GRAPHICAL USER INTERFACE WITH MORE THAN ONE PRODUCT**

- Every product has its own serial port. To control manually you can also open many soft front panel.
- Each product has its own serial number and different communication port.
- The user has also the possibility to manage the control automatically using LabView drivers provided or using Vb.net, C++ , C# with DLL provided also.

## USB Series

## GENERAL SPECIFICATIONS

OPERATING MODE		NORMALLY OPEN	
Nominal operating voltage	Vdc	5	
Coil resistance (+/-10%)	$\Omega$	11.9	
Nominal operating current at 23 °C	mA	420	
Average Power		See Power Rating Chart page 1-13	
Indicator rating		Indicators status are returned by software	
Switching time (max)	ms	15 ms	
Life (min)	Non-terminated SP6T (R573 series)	SMA 5 million cycles	SMA 2.9 2 million cycles
	Terminated SP6T (R574 series)	2 million cycles	
	SP8T (all models)		
Connectors		SMA - SMA 2.9	
Actuator terminals		Mini USB socket	
Operating temperature range	SMA - SMA 2.9	-25 °C to +75 °C	
Storage temperature range	SMA - SMA 2.9	-55 °C to +85 °C	
Vibration (MIL STD 202, method 204D, cond.D)		10 - 2,000 Hz , 20 g operating - switch only	
Shock (MIL STD 202, method 213B, cond.C)		100 g / 6 ms, 1/2 sine operating - switch only	

## RF PERFORMANCE - SP6T

CONNECTORS	FREQUENCY RANGE GHz		V.S.W.R. (MAX)	INSERTION LOSS (MAX) dB	ISOLATION (MIN) dB	IMPEDANCE $\Omega$
SMA	DC - 26.5	DC - 6	1.20	0.3 + 0.015 x frequency (GHz)	80	50
		6 - 12.4	1.35		70	
		12.4 - 20	1.45		65	
		20 - 26.5	1.70		60	
SMA 2.9	DC - 40	DC - 6	1.20		80	
		6 - 12.4	1.35		70	
		12.4 - 18	1.45		65	
		18 - 26.5	1.70		60	
		26.5 - 40	1.90		55	

## RF PERFORMANCE - SP8T

CONNECTORS	FREQUENCY RANGE GHz		V.S.W.R. (MAX)	INSERTION LOSS (MAX) dB	ISOLATION (MIN) dB	IMPEDANCE $\Omega$
SMA	DC - 26.5	DC - 3	1.20	0.20	80	50
		3 - 8	1.30	0.30	70	
		8 - 12.4	1.40	0.40	60	
		12.4 - 16	1.50	0.55	60	
		16 - 18	1.60	0.60	60	
		18 - 22	1.70	0.70	60	
		22 - 26.5	2.00	1.10	55	

USB Series

TYPICAL RF PERFORMANCE

Example: SP6T SMA up to 26.5 GHz

INSERTION LOSS & ISOLATION

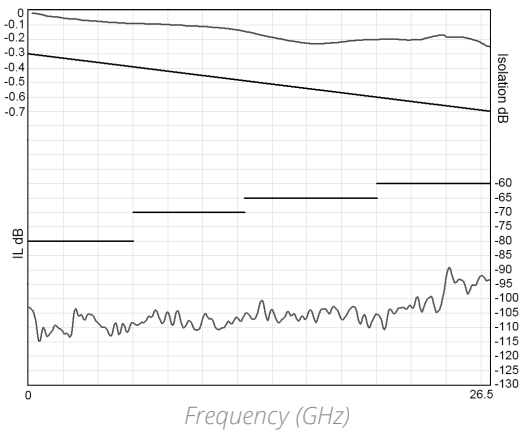

V.S.W.R

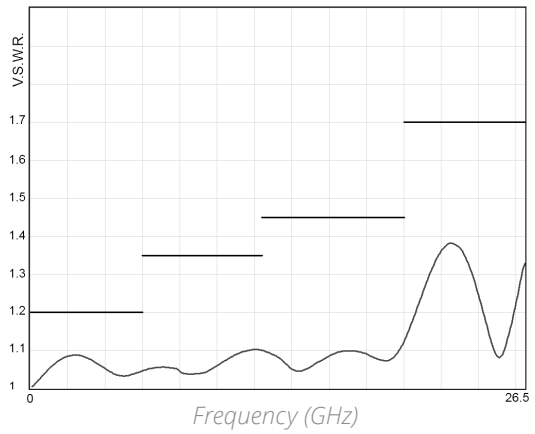

Example: SP6T SMA 2.9 up to 40 GHz

INSERTION LOSS & ISOLATION

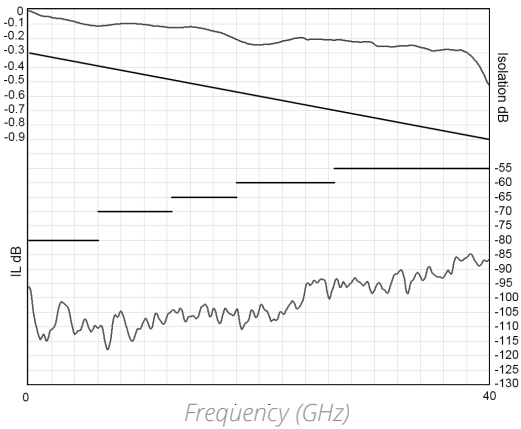

V.S.W.R

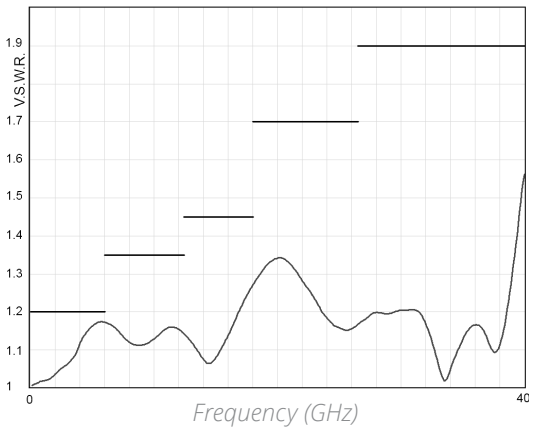

Example: SP8T SMA 2.9 up to 26.5 GHz

INSERTION LOSS & ISOLATION

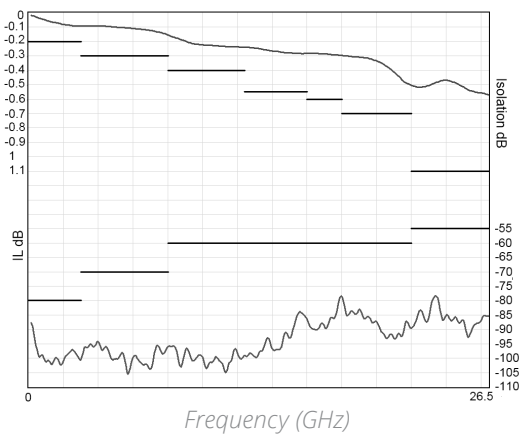

V.S.W.R

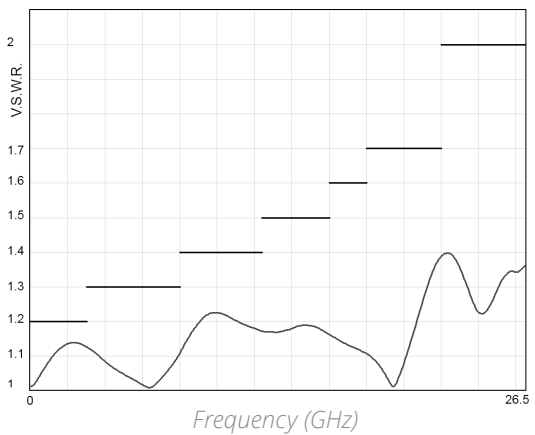

TYPICAL OUTLINE DRAWINGS

Non-terminated or terminated 6 positions

SMA MODEL

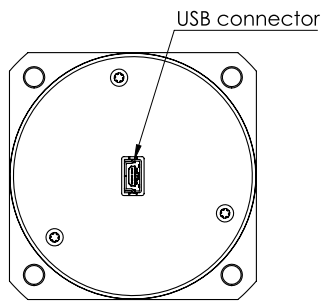
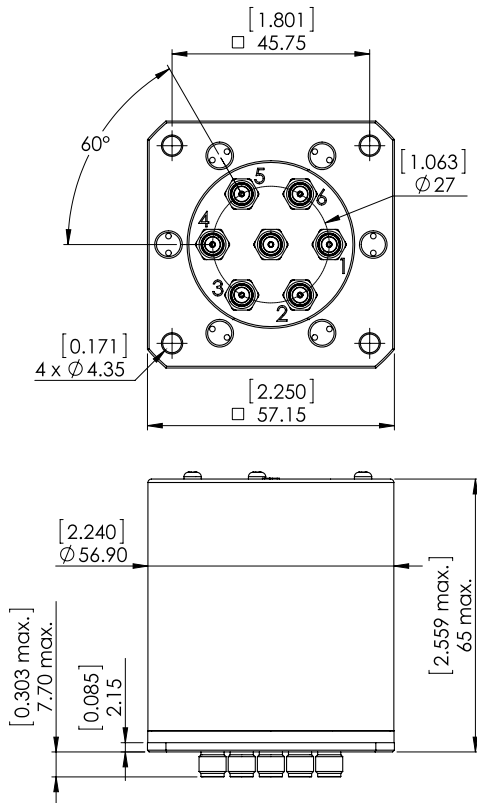

SMA 2.9 MODEL

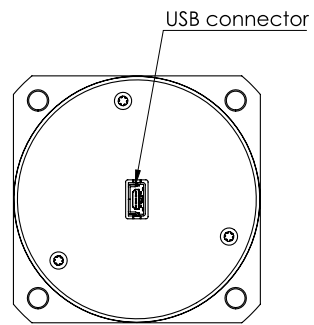
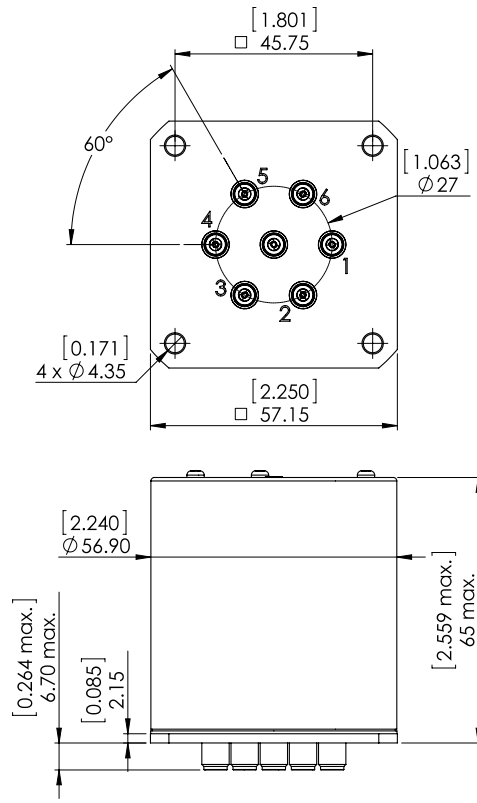

Notes

All dimensions are in millimeters [inches].

USB Series

TYPICAL OUTLINE DRAWINGS

Non-terminated or terminated 8 positions

SMA MODEL

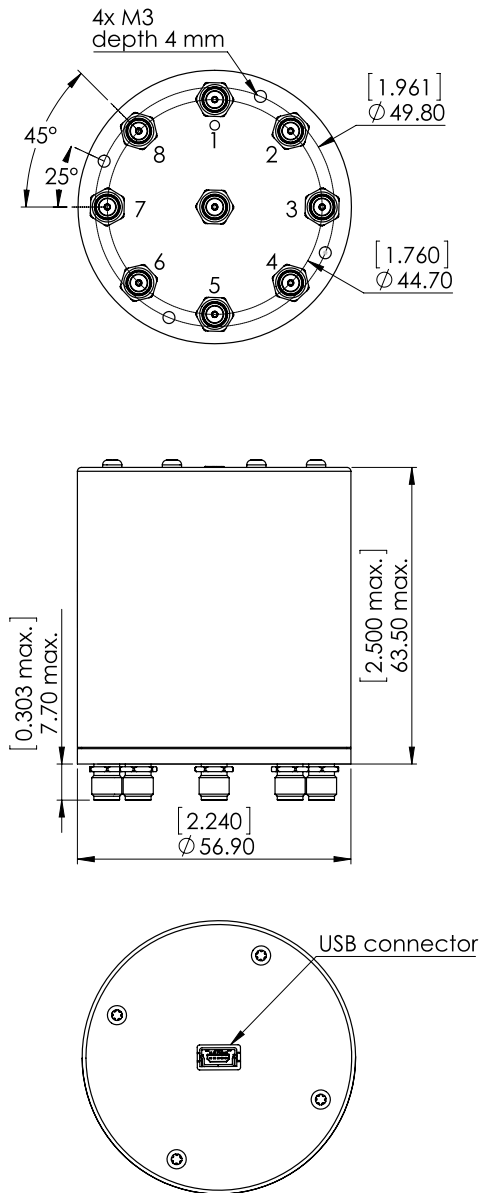

Notes

All dimensions are in millimeters [inches].  
For electrical schematics see page 5-43.

## SPNT TERMINATED & NON-TERMINATED UP TO 50 GHz

SMA - SMA 2.9 - 2.4 MM - QMA - DIN 1.6 / 5.6



Radiall's R573 and R574 multi-throw coaxial switches are offered in many configurations (over 40,000 possible combinations) including terminated and non-terminated options. Radiall offers reliable products, with shorter delivery times and competitive pricing. Excellent typical RF performance make RAMSES switches (40 GHz) ideal for Automated Test Equipment (ATE) and other measurement applications. These switches are suitable for defense, industrial, instrumentation and telecommunication applications.

Example of P/N: R574453605 is a terminated SP6T SMA up to 18 GHz, Latching, Self Cut-Off, 28 Vdc, Indicators and male 25 pin D-Sub connector.

### PART NUMBER SELECTION

## R57

#### SERIES PREFIX

#### MODEL

- 3: Without 50 Ω termination
- 4: With 50 Ω termination

#### RF CONNECTORS

- 3: SMA up to 3 GHz
- E: QMA up to 6 GHz <sup>[4, 5 & 13]</sup>
- 4: SMA up to 18 GHz <sup>[2]</sup>
- F: SMA up to 26.5 GHz <sup>[6]</sup>
- 8: SMA 2.9 up to 40 GHz <sup>[4 & 14]</sup>
- J: 2.4 mm up to 50 GHz <sup>[11]</sup>
- 9: DIN 1.6/5.6 up to 2.5 GHz <sup>[4 & 5]</sup>

#### TYPE

- 0: Normally open
- 1: Normally open I. + C.
- 2: Latching
- 3: Latching + I.C.
- 4: Latching + S.C.O. <sup>[1 & 4]</sup>
- 5: Latching + S.C.O. + I.C. <sup>[1 & 4]</sup>
- 8: Latching + S.C.O. + A.R. <sup>[1]</sup>
- 9: Latching + S.C.O. + I.C. + A.R. <sup>[1]</sup>

#### ACTUATOR TERMINALS

- 0: Solder pins
- 5: D-Sub connector

#### OPTIONS<sup>[15]</sup>

- 0: Without option
- 1: Positive common<sup>[7]</sup>
- 2: Compatible TTL driver<sup>[1, 9 & 10]</sup>
- 3: With suppression diodes
- 4: With suppression diodes and positive common<sup>[12]</sup>
- 8: BCD TTL driver compatible<sup>[1, 3, 8 & 9]</sup>

#### NUMBER OF POSITIONS

- 3: 3 positions
- 4: 4 positions
- 5: 5 positions
- 6: 6 positions
- 8: 8 positions
- 0: 10 positions
- 2: 12 positions

#### ACTUATOR VOLTAGE

- 2: 12 Vdc
- 3: 28 Vdc

### Notes

- I.C.: Indicator contact / S.C.O.: Self Cut-Off / A.R.: Auto Reset
1. These models are already equipped with suppression diodes
  2. 12 positions are available only up to 12.4 GHz, for 12 positions up to 18 GHz select digit F
  3. Latching BCD driver enables also a global reset through driver code 0000 (see BCD logic coding page 1-11)
  4. Available only up to 6 positions
  5. Model "3" only
  6. 10 positions are available only up to 22 GHz, 12 positions only up to 18 GHz
  7. From 3 to 8 positions, this option is only available for type 0, 1, 2, 3 and for type 8 and 9 combined with 28 Vdc. From 10 to 12 positions, only for type 0, 1, 2 and 3

8. Option available only with type 0, 1, 8 and 9
9. Polarity is not relevant to application for switches with TTL driver
10. From 8 to 12 positions, this option is only available with type 0, 1, 8 and 9.
11. Available only with 4 and 6 positions.
12. Option available only with type 0, 1, 2, and 3.
13. The QLF trademark (quick lock formula®) standard applies to QMA and QN series and guaranties the full intermateability between suppliers using this trademark. Using QLF certified connectors also guarantees the specified level of RF performance
14. Connector SMA 2.9 is equivalent to "K connector®", registered trademark of Anritsu
15. For precisions see availability of options chart page 5-9





**GENERAL SPECIFICATIONS**

**Type 2, 3, 4 and 5:**

Latching models have a RESET pin which commands the reset of all positions. This command should be used before switching from one position to another. If not, two positions will be set at the same time.

*Note: During the RESET operation the global current is: the nominal operating current multiplied by the number of positions.*

**Type 8, 9:**

Latching models with AUTOMATIC RESET are available; these products have an internal SET/RESET circuit which automatically resets all the non-selected positions and sets the desired position. This option simplifies the use of latching switches by suppressing the RESET command in switching sequence.

An electronic circuit supplies successively groups of 2, 3 or 4 actuators, in order to limit the maximum current. The current with this option is the total current of 2, 3 or 4 reset coils in the same time (see table below).

*Example: During the AUTOMATIC RESET operation, at 28 Vdc, 4 position switch has a temporary consumption of only 250 mA, during 40 ms maximum.*

**SWITCHING SEQUENCE**

**FOR SP6 TO 8T**

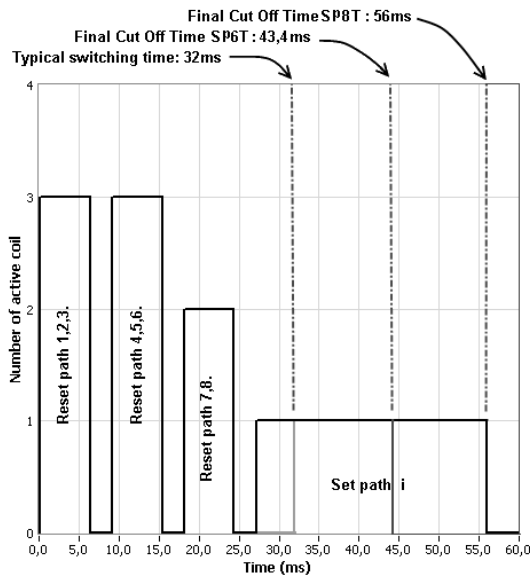

*n = number of positions*

**FOR SP10 & 12 T**

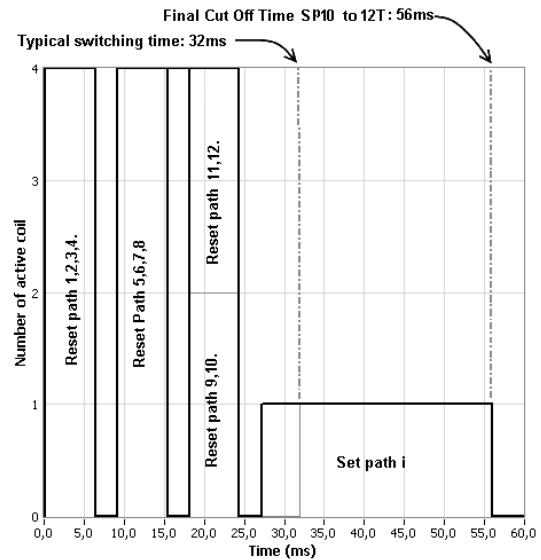

*Availability of options according to both type and number of positions.*

**OPERATING TOTAL CURRENT AT 23 °C (MA) SPNT LATCHING**

NUMBER OF POSITIONS	12 VOLTS		28 VOLTS	
	MANUAL RESET	AUTOMATIC RESET	MANUAL RESET	AUTOMATIC RESET
3 to 4	320 × n	640	125 × n	250
5 to 8	320 × n	960	125 × n	375
10 to 12	320 × n	1280	125 × n	500

TYPE	NUMBERS OF POSITIONS	AVAILABLE OPTIONS
0 or 1	3 to 12	0 - 1 - 2 - 3 - 4 - 8
	3 to 6	0 - 1 - 2 - 3 - 4
2 or 3	8 to 12	0 - 1 - 3 - 4
	3 to 6	0 - 2
4 or 5	8 to 12	N/A
	3 to 8	0 - 1 - 2 - 8
8 or 9	10 & 12	0 - 2 - 8

RAMSES Series

GENERAL SPECIFICATIONS

OPERATING MODE		NORMALLY OPEN		LATCHING	
Nominal operating voltage (across operating temperature)	Vdc	12 (10.2/13)	28 (24/30)	12 (10.2/13)	28 (24/30)
Coil resistance (+/-10%)	Ω	47.5	275	See table on previous page	
Nominal operating current at 23 °C	mA	250	102		
Average power		See Power Rating Chart page 1-13			
TTL input	High Level	2.2 to 5.5 V (TTL Option) / 800 μA max 5.5 volts 3.5 to 5.5 V (BCD Option)			
	Low Level	0 to 0.8 V (TTL Option) / 20 μA max 0.8 volts 0 to 1.5 V (BCD Option)			
Indicator rating		1 W / 30 V / 100 mA			
Switching time (Max)	ms	15 ms For automatic reset models: SP3T to SP6T = 40 ms SP8T to SP12T = 50 ms			
Life (Min)	Non-terminated SP3 to 6T (R573 series)	SMA - QMA	SMA 2.9 - 2.4 mm - 1.6/5.6		
	Terminated SP3 to 6T (R574 series)	5 million cycles	2 million cycles		
	SP8 to 12T (all models)	2 million cycles			
Connectors		SMA - SMA 2.9 - 2.4 mm - QMA - DIN 1.6/5.6			
Actuator terminals		Solder pins or male 25 pin D-sub connector			
Operating temperature range	2.4 mm - DIN 1.6/5.6	-25 °C to +70 °C			
	SMA - SMA 2.9 - QMA	-40 °C to +85 °C			
Storage temperature range	2.4 mm - DIN 1.6/5.6	-40 °C to +85 °C			
	SMA - SMA 2.9 - QMA	-55 °C to +85 °C			
Vibration (MIL STD 202, method 204D, cond.D)		10 - 2,000 Hz , 20 g operating for SP3 to 6T, survival for SP8 to 12T			
Shock (MIL STD 202, method 213B, cond.C)		100 g / 6 ms, 1/2 sine operating for SP3 to 6T, survival for SP8 to 12T			

RF PERFORMANCE - SMA CONNECTOR

NUMBER OF POSITIONS	FREQUENCY RANGE GHz	V.S.W.R. (MAX)	INSERTION LOSS (MAX) dB	ISOLATION (MIN) dB	IMPEDANCE Ω	
3 to 6	DC - 3 DC - 18 DC - 26.5	DC - 3	1.20	0.20	80	50
		3 - 8	1.30	0.30	70	
		8 - 12.4	1.40	0.40	60	
		12.4 - 18	1.50	0.50	60	
		18 - 26.5	1.70	0.70	50	
8	DC - 3 DC - 26.5	DC - 3	1.20	0.20	80	
		3 - 8	1.30	0.30	70	
		8 - 12.4	1.40	0.40	60	
		12.4 - 16	1.50	0.55	60	
		16 - 18	1.60	0.60	60	
		18 - 22	1.70	0.70	60	
10	DC - 3 DC - 22	22 - 26.5	2.00	1.10	55	
		DC - 3	1.20	0.20	80	
		3 - 8	1.30	0.30	70	
		8 - 12.4	1.40	0.40	60	
		12.4 - 15.5	1.50	0.50	60	
12	DC - 3 DC - 18	15.5 - 18	1.70	0.70	55	
		18 - 22	1.80	0.80	55	
		DC - 3	1.20	0.20	80	
		3 - 8	1.40	0.40	70	
		8 - 12.4	1.60	0.60	60	
		12.4 - 15	1.70	0.70	60	
		15 - 18	1.80	0.80	50	

RAMSES Series

RF PERFORMANCE

CONNECTORS	NUMBER OF POSITIONS	FREQUENCY RANGE GHz	V.S.W.R. (MAX)	INSERTION LOSS (MAX) DB	ISOLATION (MIN) DB	IMPEDANCE $\Omega$	
SMA 2.9	3 to 6	DC - 40	DC - 6	1.30	0.20	70	50
			6 - 12.4	1.40	0.40	60	
			12.4 - 18	1.50	0.50	60	
			18 - 26.5	1.70	0.70	55	
			26.5 - 40	2.20	1.10	50	
2.4 mm	4 or 6	DC - 50	DC - 6	1.30	0.20	70	
			6 - 12.4	1.40	0.40	60	
			12.4 - 18	1.50	0.50	60	
			18 - 26.5	1.70	0.70	55	
			26.5 - 40	1.90	0.90	50	
			40 - 50	2.20	1.20	50	
1.6/5.6	3 to 6	DC - 2.5	DC - 1	1.30	0.20	80	75
			1 - 2.5	1.40	0.30	70	
QMA	3 to 6	DC - 6	DC - 3	1.20	0.20	80	50
			3 - 6	1.30	0.30	70	

R573 & R574 TYPICAL PERFORMANCE

Example: SP6T QMA up to 6 GHz

INSERTION LOSS & ISOLATION

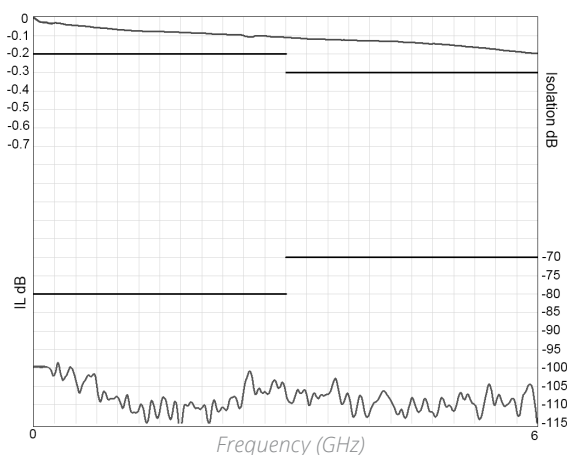

V.S.W.R.

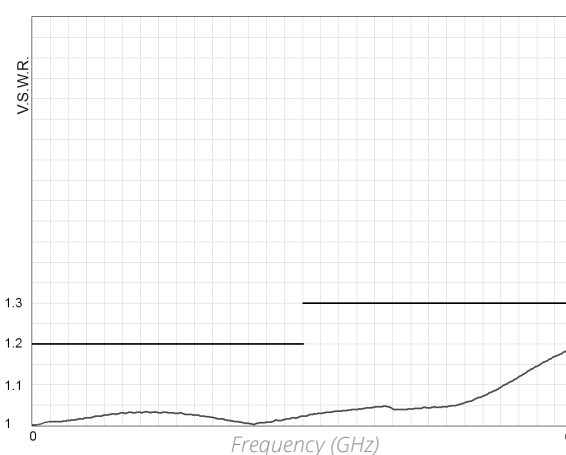

RAMSES Series

Example: Non-terminated SP6T up to 26.5 GHz

INSERTION LOSS & ISOLATION

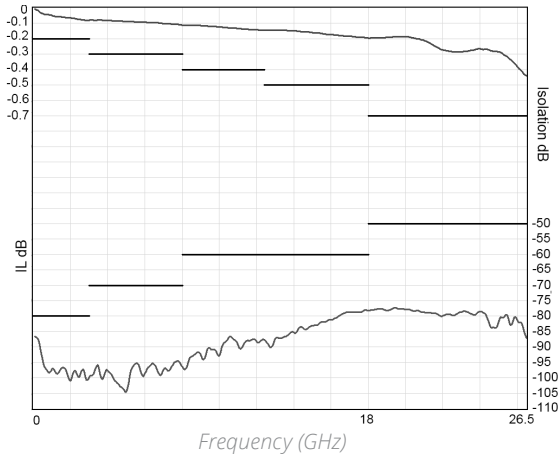

V.S.W.R

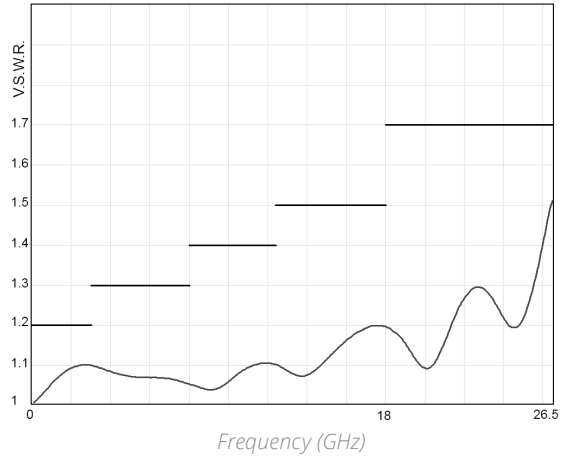

Example: Non-terminated SP6T SMA 2.9 up to 40 GHz

INSERTION LOSS & ISOLATION

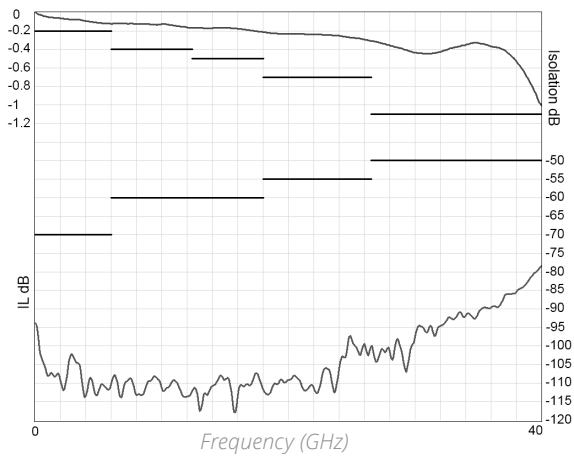

V.S.W.R

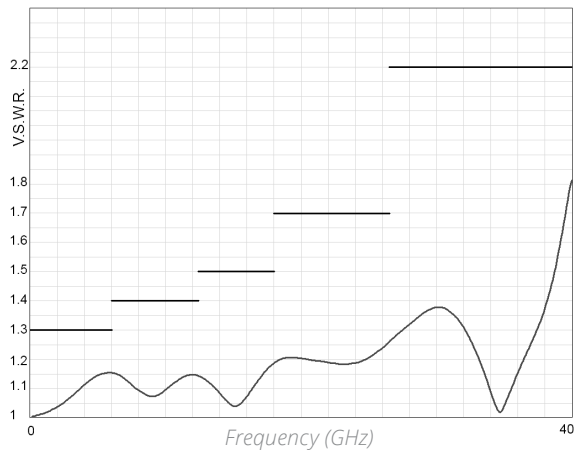

Example: Non-terminated SP6T 2.4 mm up to 50 GHz

INSERTION LOSS & ISOLATION

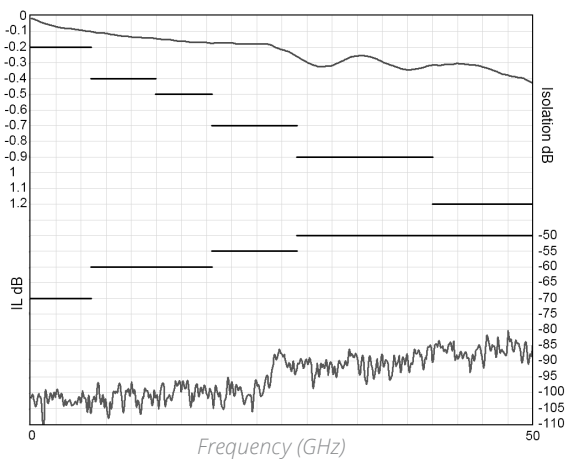

V.S.W.R

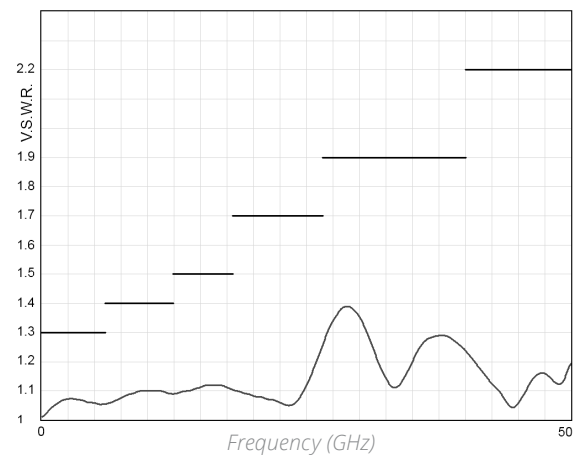

RAMSES Series

Example: Terminated SP6T up to 26.5 GHz

INSERTION LOSS & ISOLATION

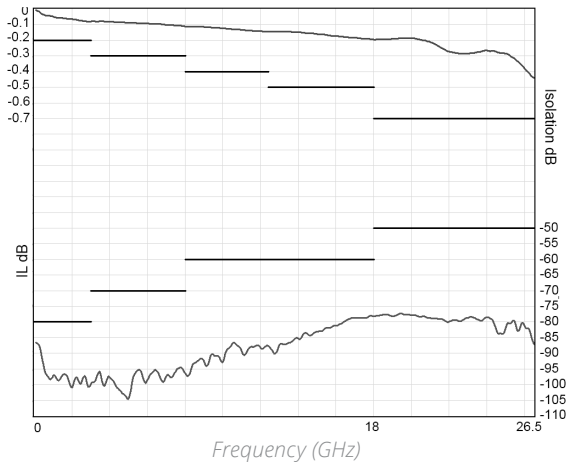

V.S.W.R

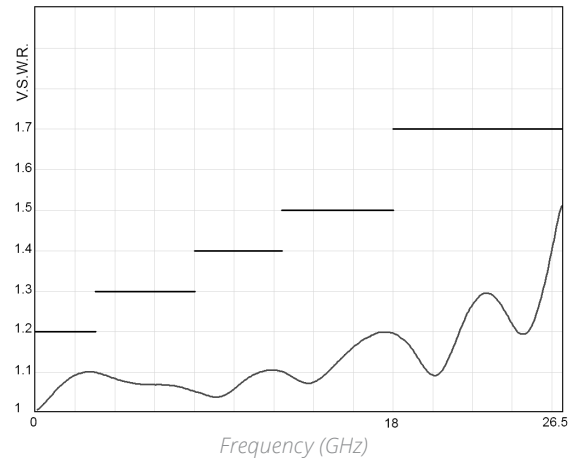

Example: Terminated SP6T SMA 2.9 up to 40 GHz

INSERTION LOSS & ISOLATION

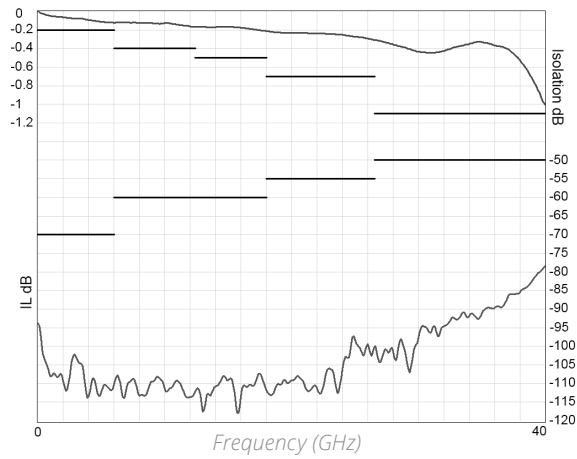

V.S.W.R

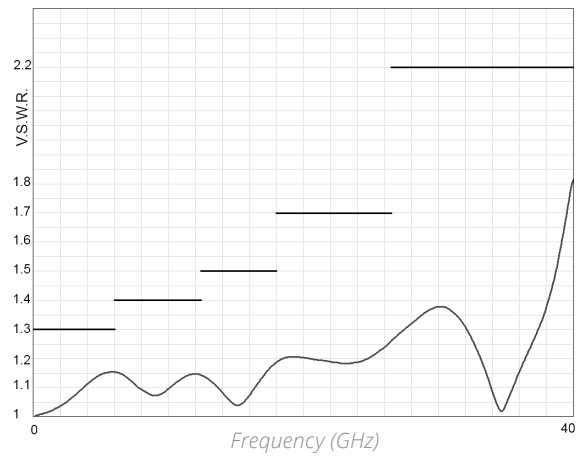

Example: Terminated SP6T 2.4 mm up to 50 GHz

INSERTION LOSS & ISOLATION

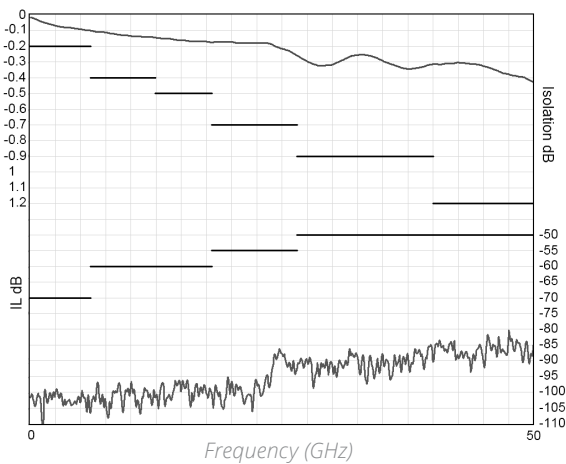

V.S.W.R

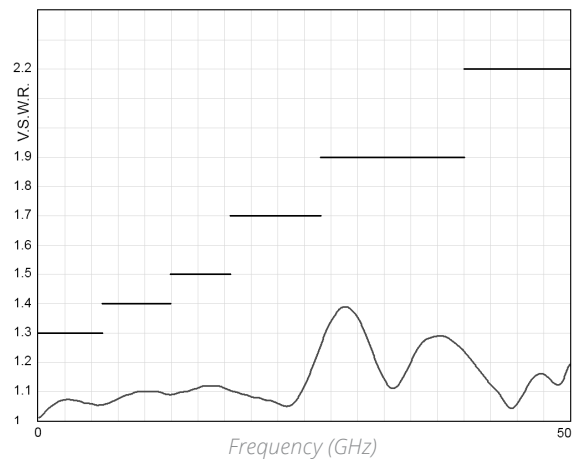

RAMSES Series

Example: Non-terminated SP6T 1.6/5.6 up to 2.5 GHz

INSERTION LOSS & ISOLATION

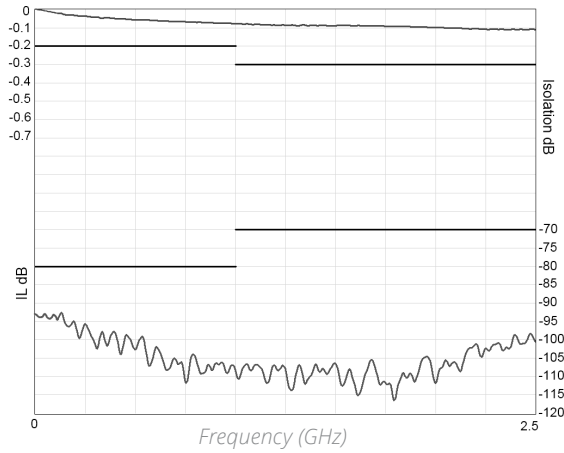

V.S.W.R

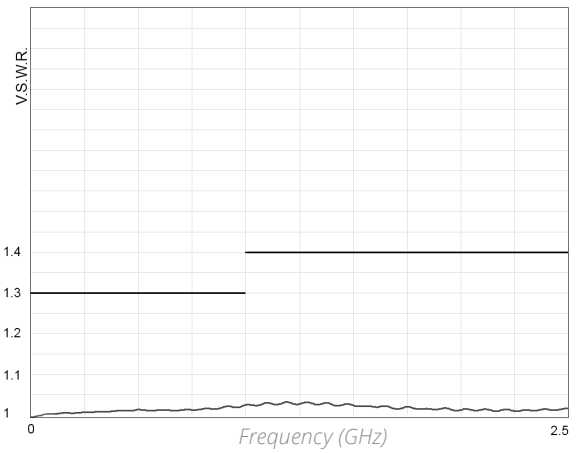

Example: SP8T SMA up to 26.5 GHz

INSERTION LOSS & ISOLATION

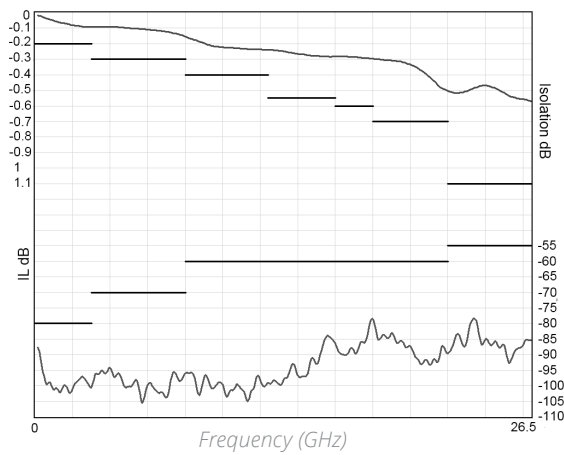

V.S.W.R

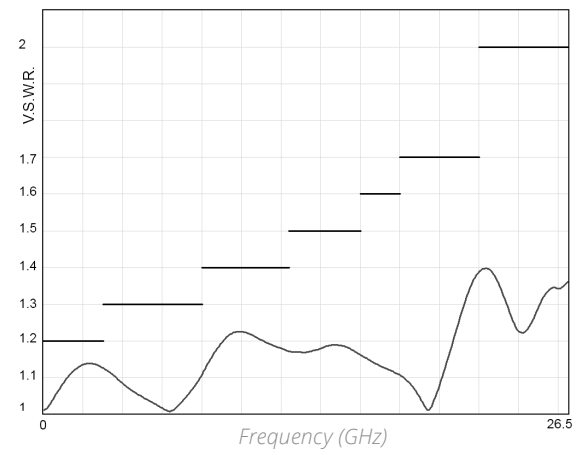

Example: SP10T SMA up to 22 GHz

INSERTION LOSS & ISOLATION

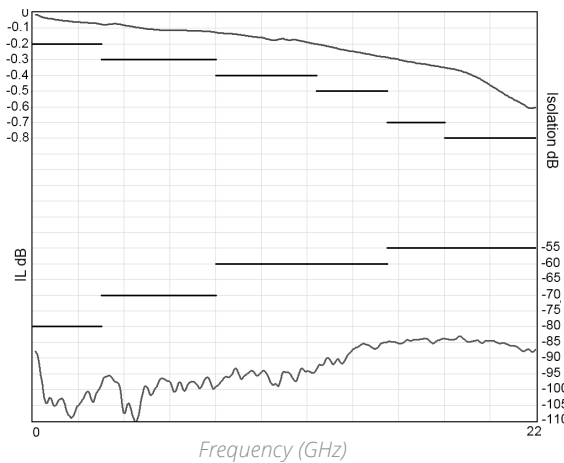

V.S.W.R

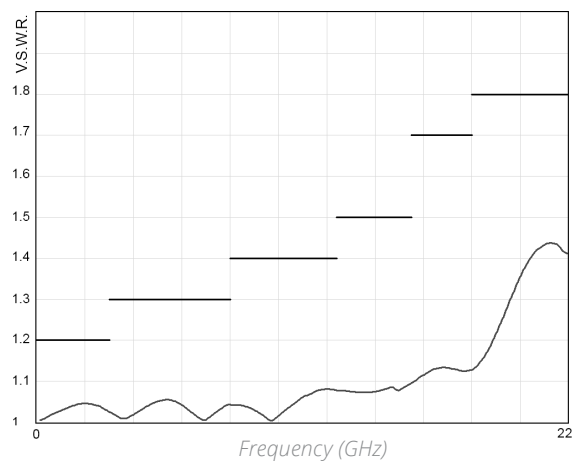

RAMSES Series

Example: SP12T SMA up to 18 GHz

INSERTION LOSS & ISOLATION

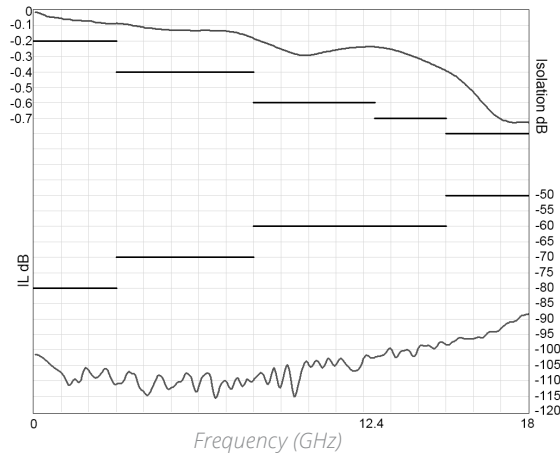

V.S.W.R

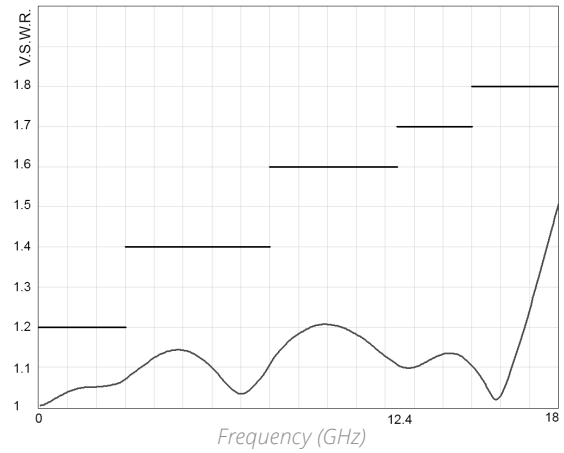

TYPICAL OUTLINE DRAWINGS

NON-TERMINATED 3 TO 6 POSITIONS

CONNECTORS	A MAX (MM [INCHES])
SMA up to 26.5 GHz	7.7 [0.303]
SMA 2.9 up to 40 GHz	6.7 [0.264]
2.4 mm up to 50 GHz	6.7 [0.264]
QMA up to 6 GHz	10.8 [0.394]
DIN 1.6 / 5.6 up to 2.5 GHz	11.5 [0.433]

SOLDER PINS	Type 0 or 1 with option 0 - 1 - 3 or 4
	Type 2 or 3 with option 0 or 1

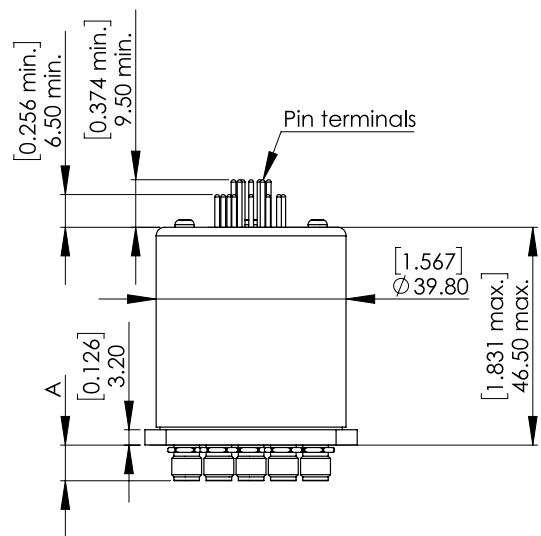
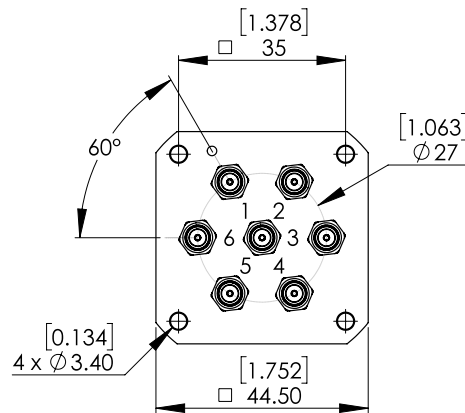

Notes

All dimensions are in millimeters [inches].

TYPICAL OUTLINE DRAWINGS

NON-TERMINATED 3 TO 6 POSITIONS (CONTINUED)

<b>SOLDER PINS</b>	Type 0 or 1 with option 2 or 8
	Type 2 or 3 with option 2 - 3 - 4 or 8
	Type 4 - 5 - 8 or 9 with option 0 - 1 - 2 or 8

<b>D-SUB CONNECTOR</b>	All models
------------------------	------------

CONNECTORS	A MAX (MM [INCHES])
SMA up to 26.5 GHz	7.7 [0.303]
SMA 2.9 up to 40 GHz	6.7 [0.264]
2.4 mm up to 50 GHz	6.7 [0.264]
QMA up to 6 GHz	10.8 [0.394]
DIN 1.6 / 5.6 up to 2.5 GHz	11.5 [0.433]

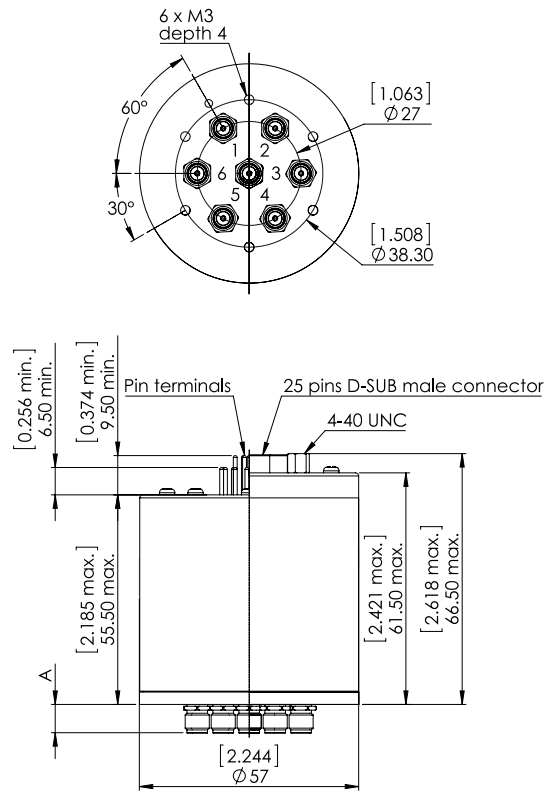



RAMSES Series

TYPICAL OUTLINE DRAWINGS

TERMINATED 3 TO 6 POSITIONS

	B
	<b>SOLDER PINS</b>
Type 0 - 1 - 2 or 3 with option 0 - 1 - 3 or 4	46.5 [1.811]
Type 0 - 1 - 2 or 3 with option 2 or 8	55.5 [2.17]
Type 4 - 5 - 8 or 9 with option 0 - 1 - 2 or 8	55.5 [2.17]

SMA 3 GHz & 18 GHz MODELS

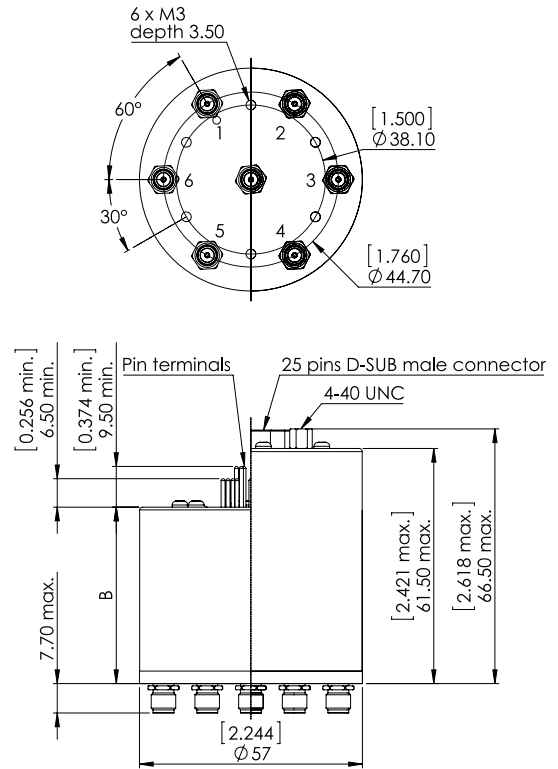

Notes

All dimensions are in millimeters [inches].

TYPICAL OUTLINE DRAWINGS

Terminated 3 to 6 positions 26.5 GHz, 40 GHz and 50 GHz

SMA 26.5 GHz MODEL

SMA 2.9 40 GHz & 2.4 MM 50 GHz MODEL

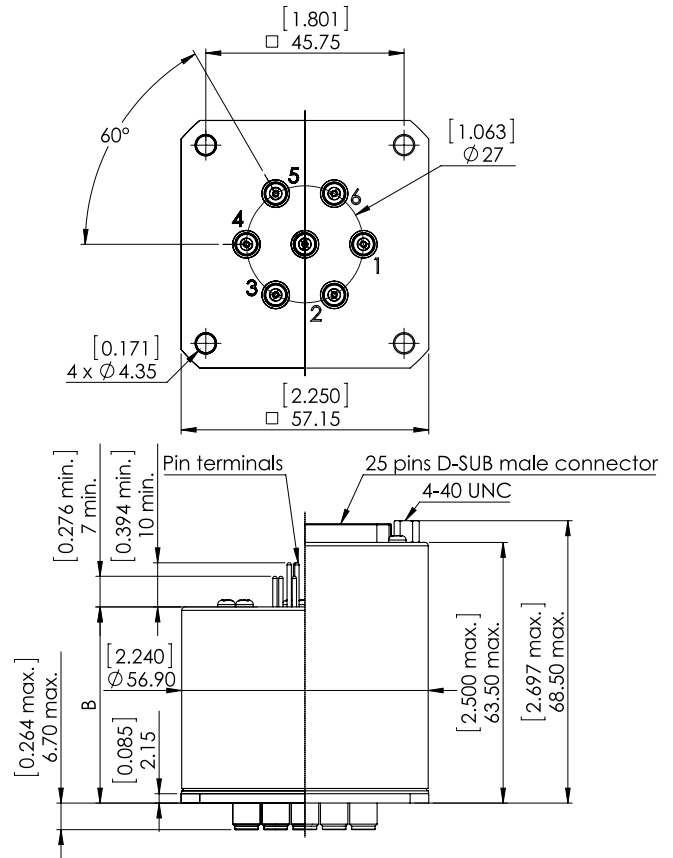
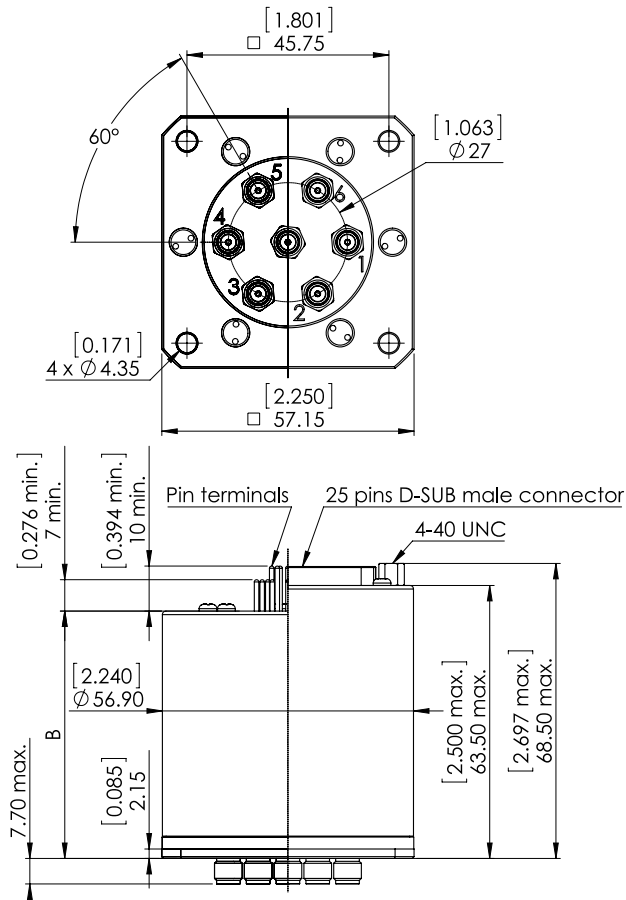

	B
	<b>SOLDER PINS</b>
Type 0 - 1 - 2 or 3 with option 0 - 1 - 3 or 4	48.5 [1.89]
Type 0 - 1 - 2 or 3 with option 2 or 8	57.5 [2.24]
Type 4 - 5 - 8 or 9 with option 0 - 1 - 2 or 8	57.5 [2.24]

Notes

All dimensions are in millimeters [inches].

TYPICAL OUTLINE DRAWINGS

Terminated or non-terminated 8 to 12 positions

TERMINATED 8 POSITIONS SMA 26.5 GHz MODEL

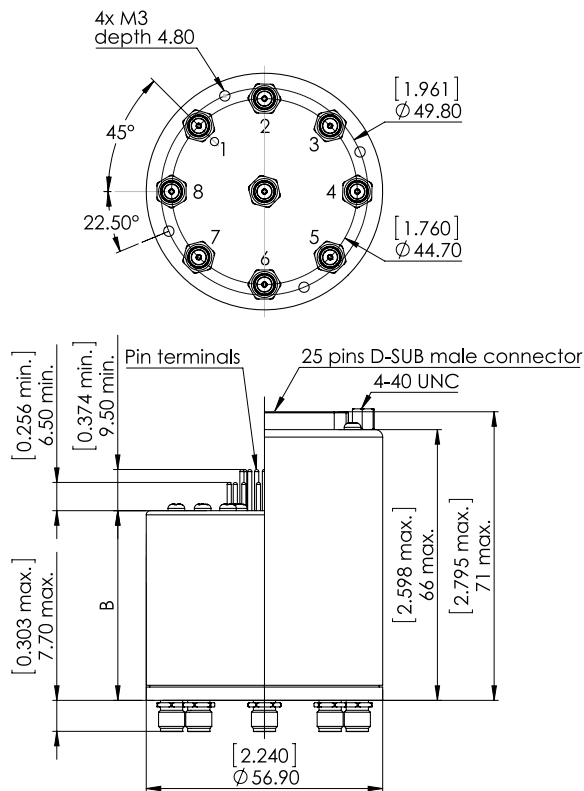

TERMINATED 10 POSITIONS SMA 22 GHz MODEL

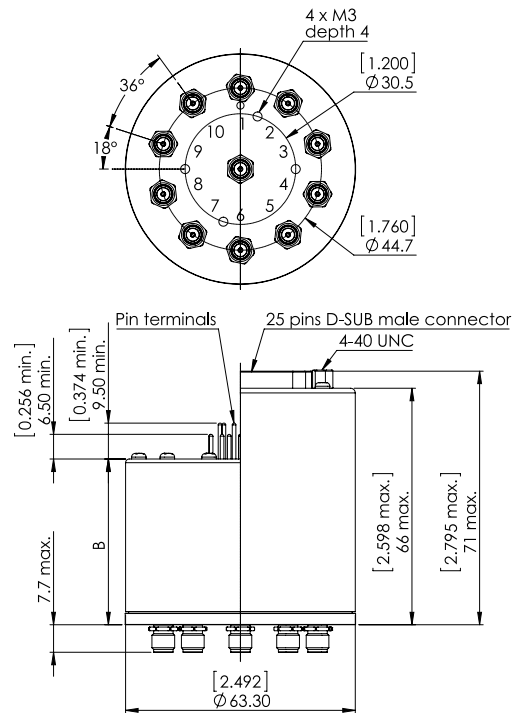

TERMINATED 12 POSITIONS SMA 18 GHz MODEL

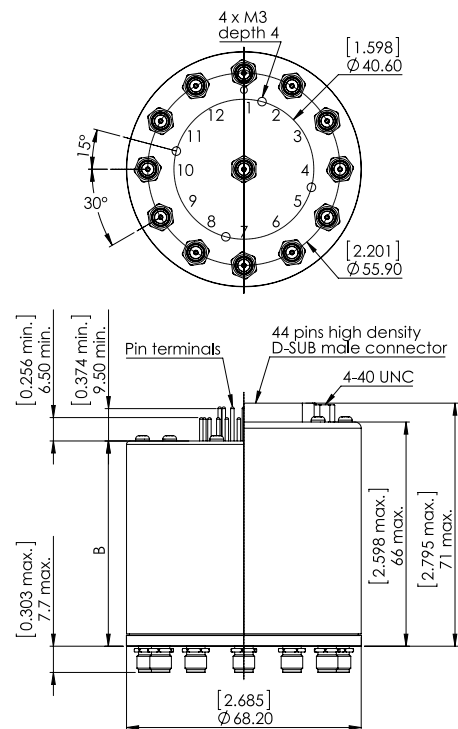

TYPE	B MAX (MM [INCHES])
	SOLDER PINS
Type 0 - 1 - 2 or 3 with option 0 - 1 - 3 or 4	50 [1.97]
Type 0 - 1 - 2 or 3 with option 2 or 8 and Type 4 - 5 - 8 or 9 with option 0 - 1 - 2 or 8	61 [2.40]

Notes

All dimensions are in millimeters [inches].

**SPNT UP TO 12.4 GHz - RAMSES CONCEPT**  
**N - BNC - TNC**



Radiall's R573 and R574 multi-throw coaxial switches are offered in many configurations (over 40,000 possible combinations), including terminated and non-terminated options. Radiall offers reliable products, with shorter delivery times and competitive pricing. Excellent typical RF performance make RAMSES switches (12.4 GHz) ideal for Automated Test Equipment (ATE) and other measurement applications. These switches are suitable for defense, industrial, and telecommunication applications.

*Example of P/N: R573103600 is a SP6T N up to 12.4 GHz, Normally Open, 28 Vdc, and solder pins.*

**PART NUMBER SELECTION**

**R57**

**SERIES PREFIX**

**MODEL**

- 3: Without 50 Ω termination
- 4: With 50 Ω termination

**RF CONNECTORS**

- 0: N up to 3 GHz <sup>[10]</sup>
- 1: N up to 12.4 GHz <sup>[8 & 10]</sup>
- 2: BNC up to 3 GHz <sup>[3 & 4]</sup>
- 5: TNC up to 3 GHz <sup>[3 & 4]</sup>
- 6: TNC up to 12.4 GHz <sup>[3 & 4]</sup>

**TYPE**

- 0: Normally open
- 1: Normally open I. + C.
- 2: Latching
- 3: Latching + I.C.
- 4: Latching + S.C.O. <sup>[1 & 3]</sup>
- 5: Latching + S.C.O. + I.C. <sup>[1 & 3]</sup>
- 8: Latching + S.C.O. + A.R. <sup>[1]</sup>
- 9: Latching + S.C.O. + I.C. + A.R. <sup>[1]</sup>

**ACTUATOR TERMINALS**

- 0: Solder pins
- 5: D-Sub connector

**OPTIONS<sup>[11]</sup>**

- 0: Without option
- 1: Positive common <sup>[5]</sup>
- 2: Compatible TTL driver <sup>[1, 7 & 9]</sup>
- 3: With suppression diodes
- 4: With suppression diodes and positive common <sup>[5]</sup>
- 8: BCD TTL driver compatible <sup>[1, 2, 6 & 7]</sup>

**NUMBER OF POSITIONS**

- 3: 3 positions
- 4: 4 positions
- 5: 5 positions
- 6: 6 positions
- 8: 8 positions
- 0: 10 positions
- 2: 12 positions

**ACTUATOR VOLTAGE**

- 2: 12 Vdc
- 3: 28 Vdc

**Notes**

- I.C.: Indicator contact / S.C.O. : Self Cut-Off / A.R. : Auto Reset
- Standard products are equipped with negative common
- 1. These models are already equipped with suppression diodes
- 2. Latching BCD driver enables also a global reset through driver code 0000 (see BCD logic coding page 1-13)
- 3. Available only up to 6 positions
- 4. Model "3" only
- 5. Available only for type 0, 1, 2 and 3

- 6. Available only with type 0, 1, 8 and 9
- 7. Polarity is not relevant to application for switches with TTL driver
- 8. 8 to 12 positions are available only up to 8 GHz
- 9. From 8 to 12 positions, this option is only available with type 0, 1, 8 and 9
- 10. From 8 to 12 positions, this connector is only available without 50 Ω termination
- 11. For precisions see availability of options chart page 5-27

**GENERAL SPECIFICATIONS**

**Type 2, 3, 4 and 5:**

Latching models have a RESET pin which commands the reset of all positions. This command should be used before switching from one position to another. If not, two positions will be set at the same time.

*Note: During the RESET operation, the global current and the nominal operating current are multiplied by the number of positions.*

**Type 8, 9:**

Latching models with AUTOMATIC RESET are available; these products have an internal SET/RESET circuit which automatically resets all the non-selected positions and sets the desired position. This option simplifies the use of latching switches by suppressing the RESET command in switching sequence.

An electronic circuit supplies successively groups of 2, 3 or 4 actuators, in order to limit the maximum current. The current with this option is the total current of 2, 3 or 4 reset coils in the same time (see table below).

*Example: During the AUTOMATIC RESET operation, at 28 Vdc, 4 position switch has a temporary consumption of only 250 mA, during 40 ms maximum.*

**SWITCHING SEQUENCE**

**FOR SP6 TO 8T**

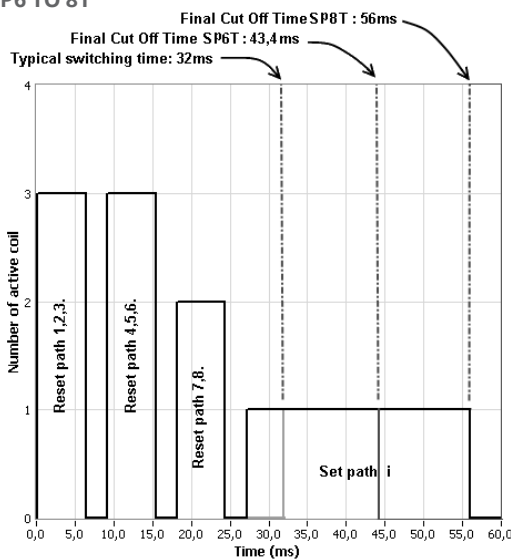

**FOR SP10 TO 12T**

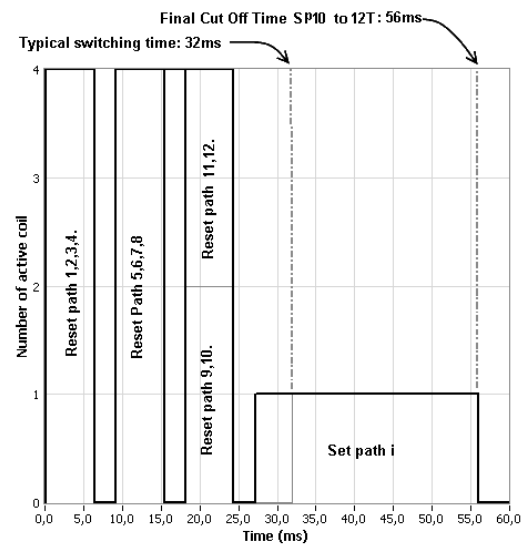

*n = number of positions*

*Availability of options according to both type and number of positions.*

**OPERATING TOTAL CURRENT AT 23 °C (MA)  
SPNT LATCHING**

NUMBER OF POSITIONS	12 VOLTS		28 VOLTS	
	MANUAL RESET	AUTOMATIC RESET	MANUAL RESET	AUTOMATIC RESET
3 to 4	320 × n	640	125 × n	250
5 to 8	320 × n	960	125 × n	375
9 to 12	320 × n	1280	125 × n	500

TYPE	NUMBERS OF POSITIONS	AVAILABLE OPTIONS
0 or 1	3 to 12	0 - 1 - 2 - 3 - 4 - 8
2 or 3	3 to 6	0 - 1 - 2 - 3 - 4
	8 to 12	0 - 1 - 3 - 4
4 or 5	3 to 6	0 - 2
	8 to 12	N/A
8 or 9	3 to 12	0 - 2 - 8

RAMSES Series

**GENERAL SPECIFICATIONS**

OPERATING MODE		NORMALLY OPEN		LATCHING	
Nominal operating voltage (across operating temperature)	Vdc	12 (10.2/13)	28 (24/30)	12 (10.2/13)	28 (24/30)
Coil resistance (+/-10%)	Ω	47.5	275	See table on previous page	
Nominal operating current at 23 °C	mA	250	102		
Average power		See Power Rating Chart page 1-13			
TTL input	High Level	2.2 to 5.5 V (TTL Option)			
		3.5 to 5.5 V (BCD Option)	800 μA max 5.5 volts		
	Low Level	0 to 0.8 V (TTL Option)			
		0 to 1.5 V (BCD Option)	20 μA max 0.8 volts		
Indicator rating		1 W/30 V/100 mA			
Switching time (max)	ms	15 ms For automatic reset models: SP3T to SP6T = 40 ms SP8T to SP12T = 50 ms			
Life (min)	Non-terminated SP3 to 6T (R573 series)		2 million cycles		
	Terminated SP3 to 6T (R574 series)				
	SP8 to 12T (all models)				
Connectors		N - TNC - BNC			
Actuator terminals		Solder pins or male 25 pin D-Sub connector			
Operating temperature range		-40 °C to +85 °C			
Storage temperature range		-55 °C to +85 °C			
Vibration (MIL STD 202, method 204D, cond.C)		10 - 2,000 Hz, 10 g	operating		
Shock (MIL STD 202, method 213B, cond.C)		50 g/1 ms, 1/2 sine	operating		

**RF PERFORMANCE**

N - TNC - BNC Connector

NUMBER OF POSITIONS	FREQUENCY RANGE GHz	V.S.W.R. (MAX)	INSERTION LOSS (MAX) dB	ISOLATION (MIN) dB	IMPEDANCE Ω
3 to 6	DC - 12.4	DC - 3	1.20	0.20	80
		3 - 8	1.35	0.35	70
		8 - 12.4	1.50	0.50	60
8 & 10	DC - 8	DC - 3	1.30	0.30	80
		3 - 8	1.50	0.50	70
12	DC - 8	DC - 3	1.35	0.50	70
		3 - 8	1.70	1.00	60

**Notes**

See page 5-29 for typical RF performance.

RAMSES Series

R573 & R574 TYPICAL PERFORMANCE

Example: SP6T N up to 12.4 GHz

INSERTION LOSS & ISOLATION

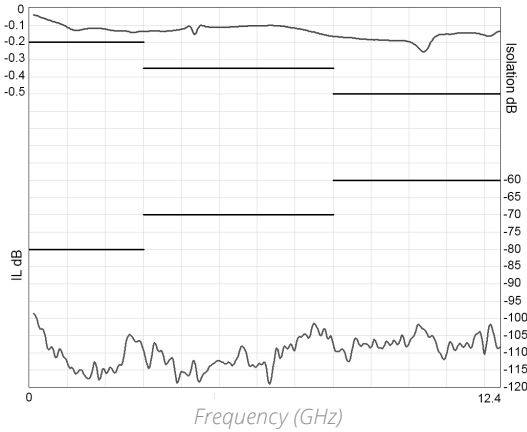

V.S.W.R

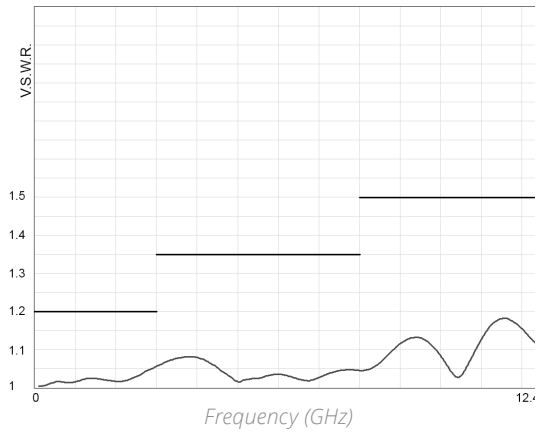

Example: SP6T TNC up to 12.4 GHz

INSERTION LOSS & ISOLATION

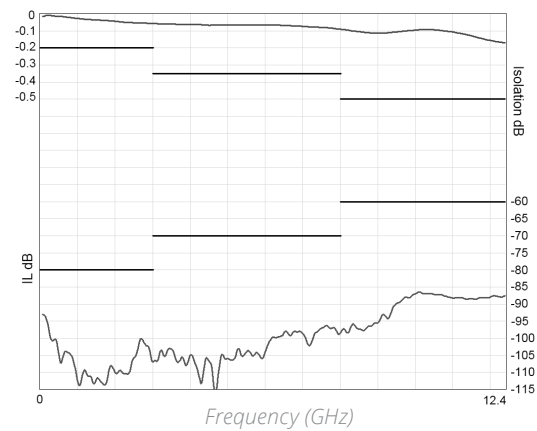

V.S.W.R

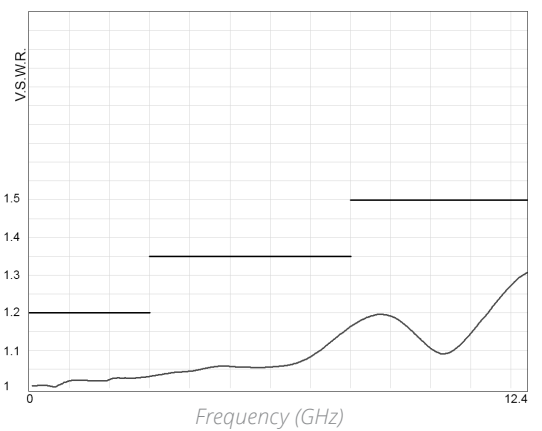

Example: SP8T up to 8 GHz

INSERTION LOSS & ISOLATION

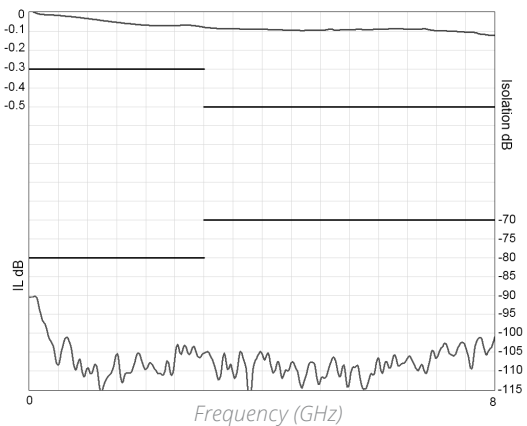

V.S.W.R

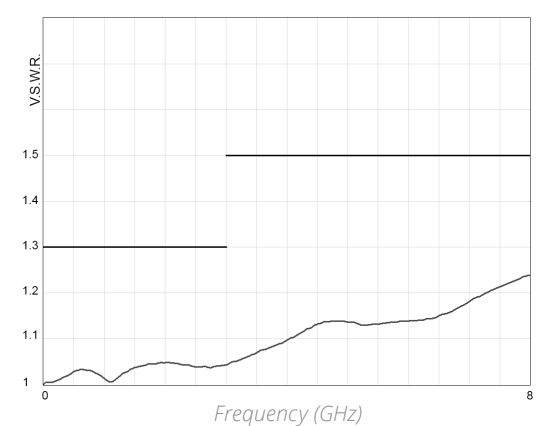

TYPICAL OUTLINE DRAWINGS

Terminated or non-terminated 3 to 12 positions

8 POSITIONS 8 GHz WITH SOLDER PINS MODEL

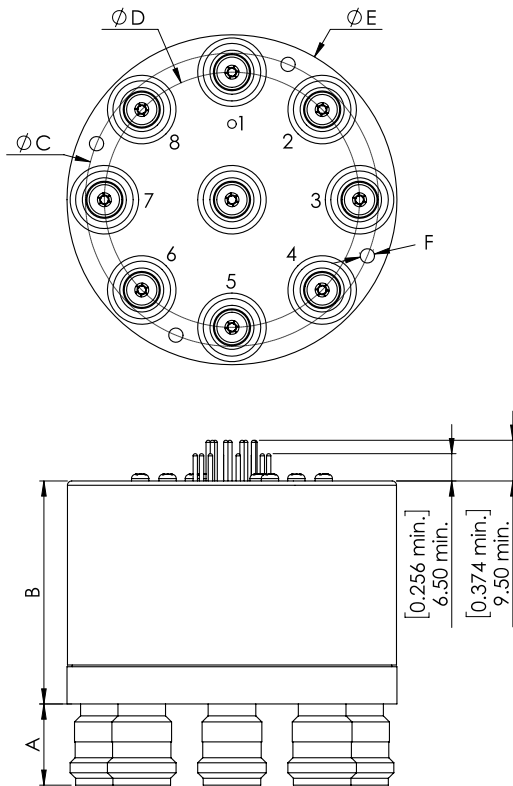

10 POSITIONS 8 GHz WITH D-SUB CONNECTOR MODEL

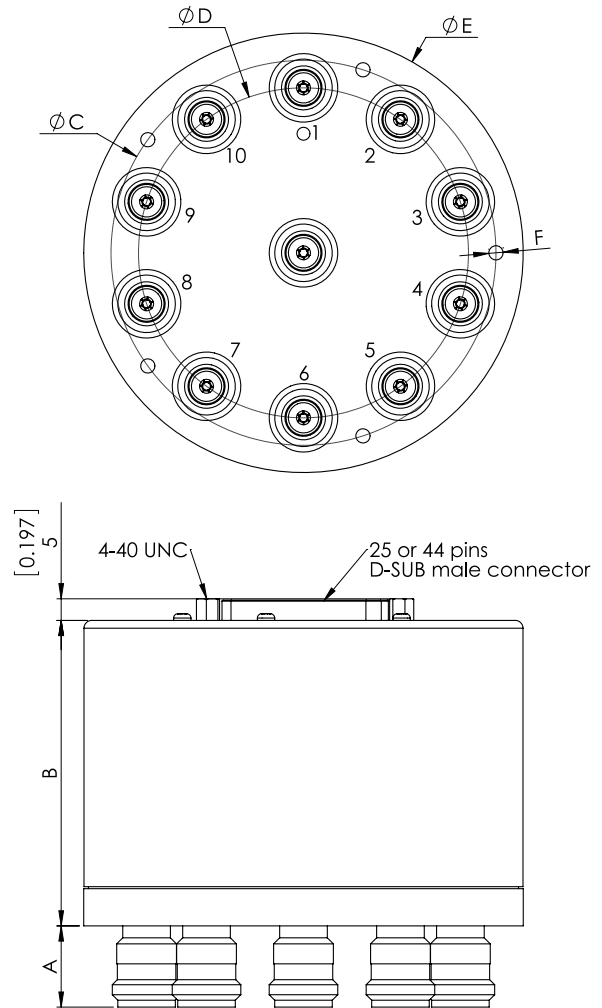

CONNECTORS	A MAX (MM [INCHES])
N	19.5 [0.748]
BNC	12.5 [0.472]
TNC	12.5 [0.472]

TYPE	B MAX (MM [INCHES])	
	SOLDER PINS	D-SUB CONNECTOR
Type 0 - 1 - 2 or 3 with option 0 - 1 - 3 or 4	56 [2.205]	66 [2.598]
Type 0 - 1 - 2 or 3 with option 2 or 8	71 [2.80]	71 [2.80]
Type 4 - 5 - 8 or 9 with option 0 - 1 - 2 or 8		

NUMBER OF POSITIONS	C DIAMETER	D DIAMETER	E DIAMETER	F
3 - 6	54 [2.126]	44.7 [1.732]	63.5 [2.480]	6 holes M4/60°
8	67.7 [2.738]	58.9 [2.283]	76.2 [2.99]	4 holes M4/90°
10	88.9 [3.465]	76.2 [2.992]	101.6 [3.976]	5 holes M4/72°
12	67.7 [2.738]	101.6 [3.976]	127 [5]	6 holes M4/60°

Notes

All dimensions are in millimeters [inches].



RAMSES Series

## RF CONNECTOR ALLOCATION FOR SPNT SERIES

### ALL CONNECTORS

Connectors A: 1.6/5.6, QMA, SMA, SMA 2.9, 2.4 mm

Other Connectors: N, BNC, TNC

#### SPNT 3 WAYS

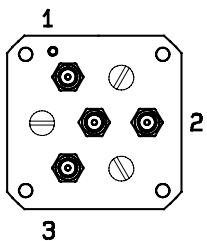
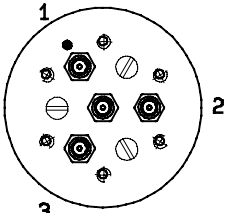
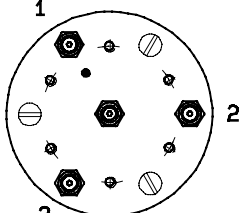
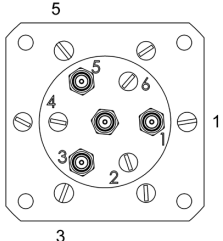
NON-TERMINATED VERSION		TERMINATED VERSION	
Up to 40 GHz models Without option Connectors A (except 2.4 mm)	Up to 40 GHz models With option Connectors A and other connectors (except 2.4 mm)	Up to 18 GHz models Connectors A and other connectors (except 2.4 mm)	26.5 GHz and 40 GHz models with SMA - SMA 2.9
			

#### SPNT 4 WAYS

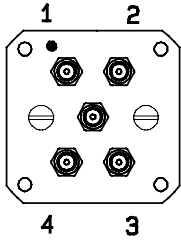
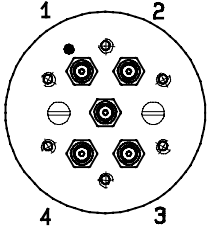
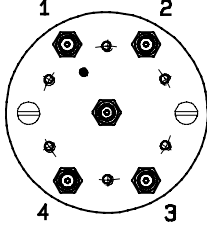
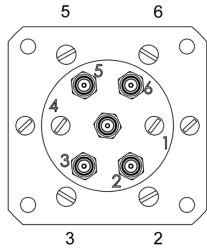
NON-TERMINATED VERSION		TERMINATED VERSION	
Up to 50 GHz models Without option Connectors A	Up to 50 GHz models With option Connectors A and other connectors	Up to 18 GHz models Connectors A and other connectors (except 2.4 mm)	26.5 GHz, 40 GHz and 50 GHz models with SMA - SMA 2.9 - 2.4 mm
			

#### SPNT 5 WAYS

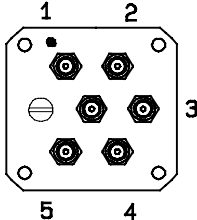
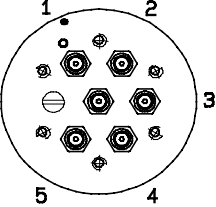
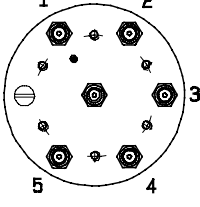
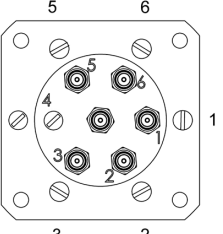
NON-TERMINATED VERSION		TERMINATED VERSION	
Up to 40 GHz models Without option Connectors A (except 2.4 mm)	Up to 40 GHz models With option Connectors A and other connectors (except 2.4 mm)	Up to 18 GHz models Connectors A and other connectors (except 2.4 mm)	26.5 GHz and 40 GHz models with SMA - SMA 2.9
			

RAMSES Series

Connectors A: 1.6/5.6, QMA, SMA, SMA 2.9, 2.4 mm

Other Connectors: N, BNC, TNC

SPNT 6 WAYS

NON-TERMINATED VERSION		TERMINATED VERSION	
Up to 50 GHz models Without Option Connectors A	Up to 50 GHz models With Option Connectors A and other connectors	Up to 22 GHz models Connectors A and other connectors	26.5 GHz, 40 GHz and 50 GHz models with SMA - SMA 2.9 - 2.4 mm

SPNT 8 WAYS	SPNT 10 WAYS	SPNT 12 WAYS
SMA and N connectors	SMA and N connectors	SMA and N connectors

## COAXIAL SPNT - ACCESSORIES

### PRINTED CIRCUIT BOARD INTERFACE CONNECTOR

A printed circuit board interface connector (ordered separately) has been designed for easy mounting on terminals

For SPnT model R573 and R574 series: Radiall part number: R599 906 000 for 3 to 6 positions, R599 908 000 for 8 positions, R599 900 000 for 10 positions, and R599 902 000 for 12 positions.

R599906000

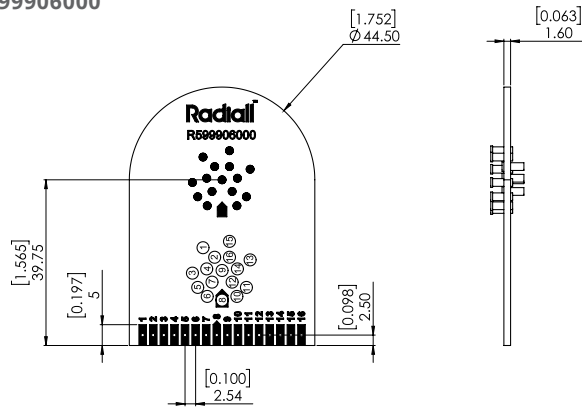

( $\varnothing$ 0.8 [0.031] metallized holes, double side tracks)

R599902000

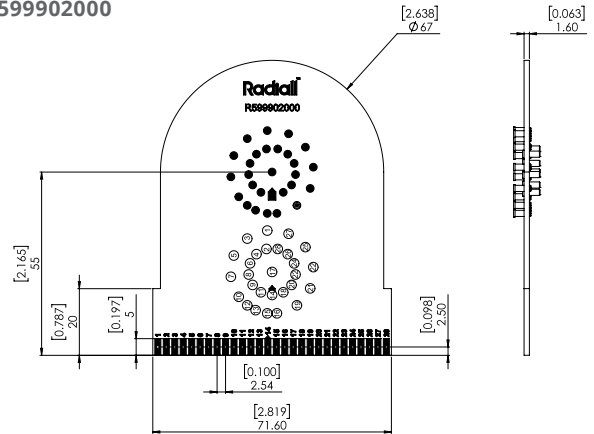

( $\varnothing$ 0.8 [0.031] metallized holes, double side tracks)

R599908000

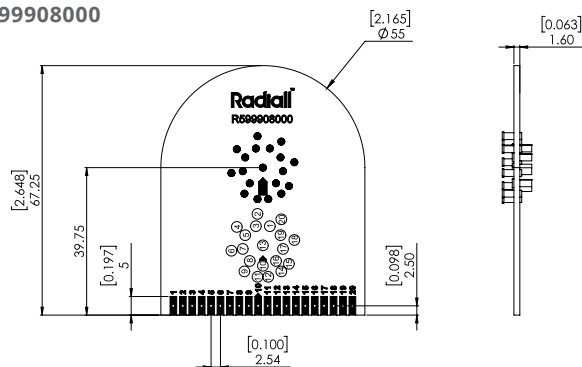

( $\varnothing$ 0.8 [0.031] metallized holes, double side tracks)

R599900000

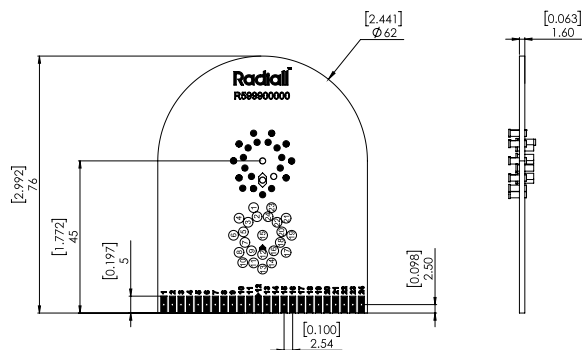

( $\varnothing$ 0.8 [0.031] metallized holes, double side tracks)



**Mounting Bracket**

Two different metal brackets have been designed for an easy mechanical mounting of our SPnT switches with a circular flange for customer installation. These brackets must be ordered separately and assembled according to our recommended process on the Technical Data Sheets.

**MODEL WITH SCREWS (R599320000)**

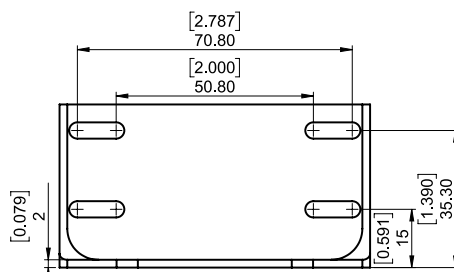
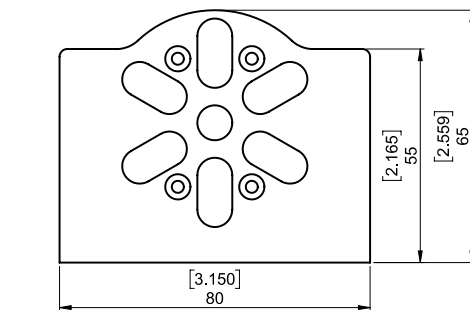
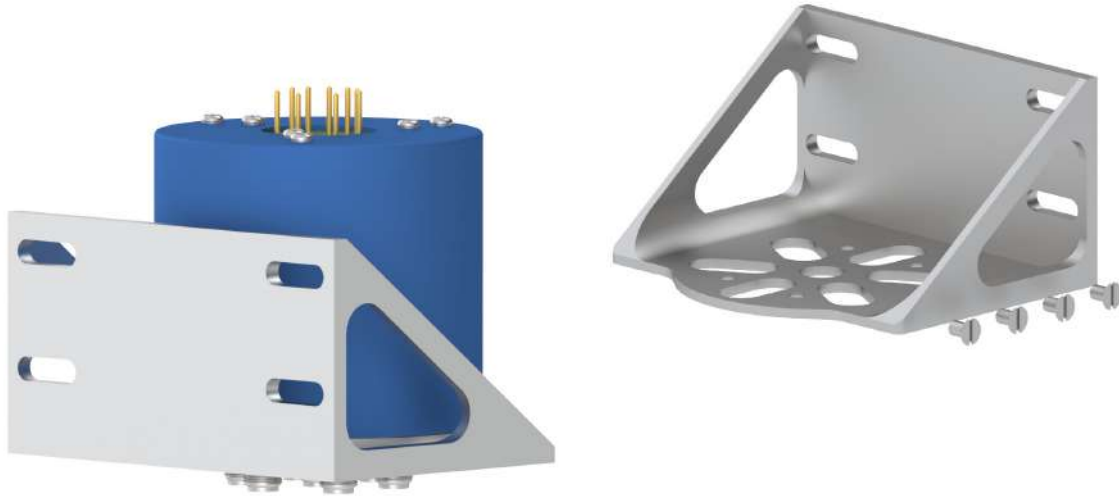

General tolerances : ±0.5 mm [0.02 in]

**Notes**

All dimensions are in millimeters [inches].  
For assembling process please see Technical Data Sheet.

**MODEL WITH ADHESIVE (R59992X000)**

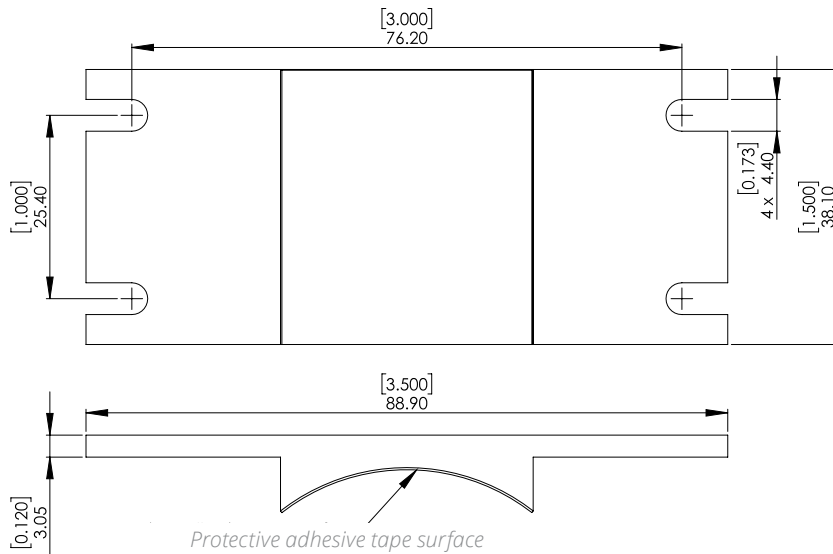
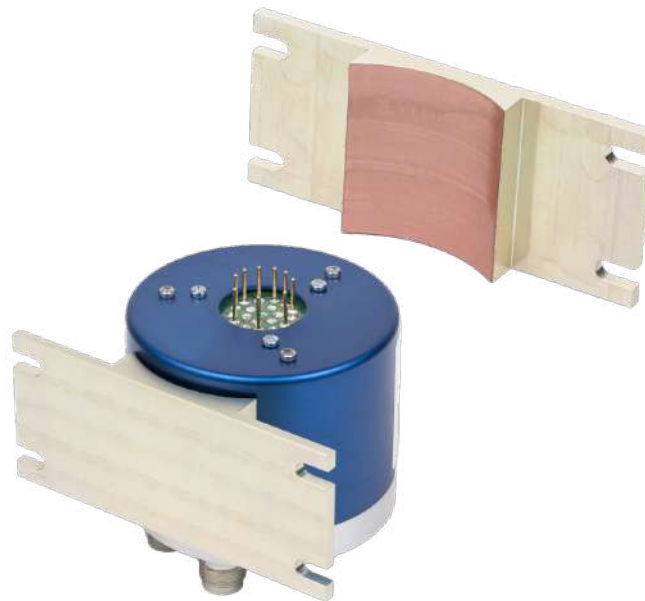

**GENERAL TOLERANCES: ±0.5 MM [0.02]**

**Notes**

All dimensions are in millimeters [inches].  
 This model can also be mounted on our SPnT switches with a square flange.  
 For adhesive bonding process please see Technical Data Sheet.

**FOR MODELS WITH CONNECTORS SMA, QMA, SMA 2.9, 2.4 MM, DIN 1.6/5.6**

NUMBER OF POSITIONS	MODEL	PART NUMBER
3 to 6 positions	R573 series	R599320000
	R574 series	R599920000
8 positions	R573 series	R599920000
	R574 series	
10 positions	R573 series	R599921000
	R574 series	
12 positions	R573 series	R599922000
	R574 series	

**FOR MODELS WITH CONNECTORS N, TNC, BNC**

NUMBER OF POSITIONS	MODEL	PART NUMBER
3 to 6 positions	R573 series	R599921000
	R574 series	
8 to 12 positions	R573 series	Not Available
	R574 series	

**MOUNTING SQUARE FLANGE**

A square flange has been designed for easy mechanical mounting of our SPnT switches with a circular flange for customer installation. These flanges must be ordered separately (similar to the mounting bracket) and assembled according to our recommended process on the following page.



**TYPICAL OUTLINE DRAWING**

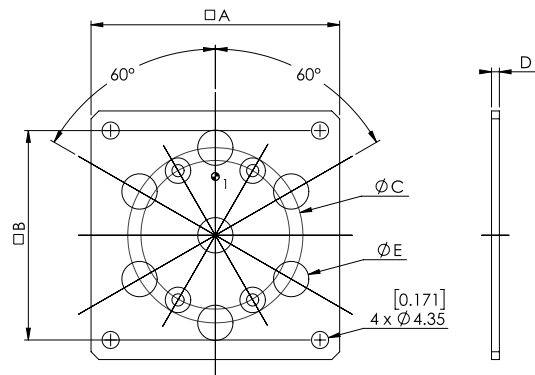

Accessories SPnT & Electrical Schematics

**MATERIAL: ALUMINIUM WITH CR3 PASSIVATION**

RADIALL PART NUMBER	A (MM [INCHES])	B (MM [INCHES])	C (MM [INCHES])	D (MM [INCHES])	E (MM [INCHES])
R599 308 000	57.15 [2.244]	45.75 [1.772]	27 [1.063]	2 [0.079]	9 [0.354]
R599 309 000	57.15 [2.244]	45.75 [1.772]	44.70 [1.732]	2 [0.079]	9 [0.354]
R599 310 000	63.45 [2.480]	53.45 [2.087]	27 [1.063]	2 [0.079]	9 [0.354]
R599 311 000	63.45 [2.480]	53.45 [2.087]	44.70 [1.732]	2 [0.079]	9 [0.354]
R599 312 000	63.45 [2.480]	53.45 [2.087]	44.70 [1.732]	2 [0.079]	9 [0.354]
R599 313 000	69.80 [2.717]	59.80 [2.323]	44.70 [1.732]	2 [0.079]	9 [0.354]
R599 314 000	74.60 [2.913]	64.60 [2.520]	55.88 [2.165]	2 [0.079]	9 [0.354]
R599 315 000	71.10 [2.795]	60.30 [2.362]	44.70 [1.732]	3 [0.118]	16.20 [0.630]

**FOR MODELS WITH CONNECTORS SMA, QMA, SMA 2.9, 2.4 MM, DIN 1.6/5.6**

NUMBER OF POSITIONS	MODEL	PART NUMBER
3 to 6 positions	R573 series	R599310000
		R599308000
	R574 series	R599311000
		R599309000
8 positions	R573 series	R599312000
	R574 series	
10 positions	R573 series	R599313000
	R574 series	
12 positions	R573 series	R599314000
	R574 series	

**FOR MODELS WITH CONNECTORS N, TNC, BNC**

NUMBER OF POSITIONS	MODEL	PART NUMBER
3 to 6 positions	R573 series	R599315000
	R574 series	

**D-SUB CONNECTOR LOCATION**

**R573 & R574**

3 to 6 positions

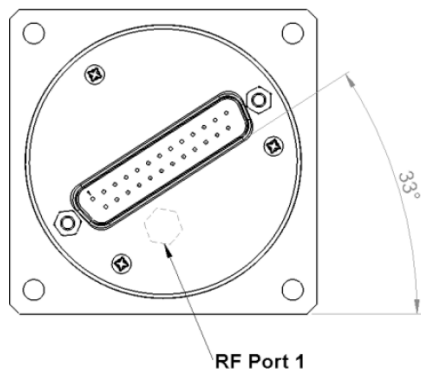

**R573 & R574**

10 positions

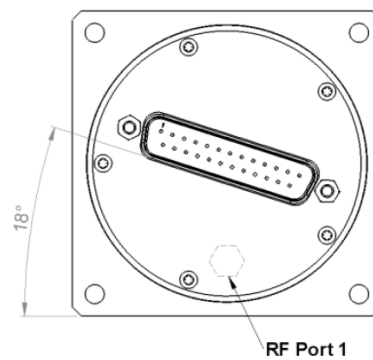

**R573 & R574**

8 & 12 positions

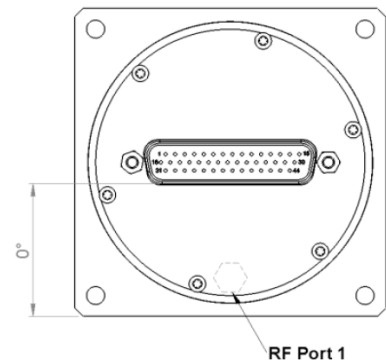

**Notes**

All dimensions are in millimeters [inches]. For assembling process please see Technical Data Sheet.

## COAXIAL SPNT - ELECTRICAL SCHEMATICS

### R573 - R574 SERIES

NORMALLY OPEN

#### WITHOUT OPTION

R573-0--0- / R574-0--0-

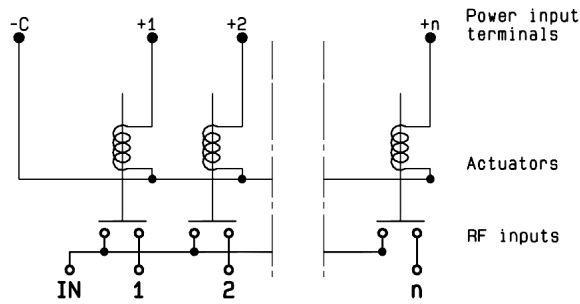

#### WITH INDICATOR CONTACT

R573-1--0- / R574 -1- -0-

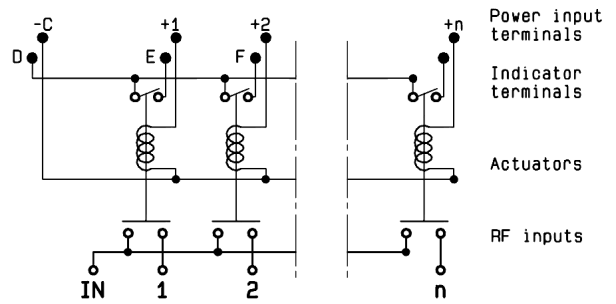

#### WITH SUPPRESSION DIODES

R573-0--3- / R574 -0- -3-

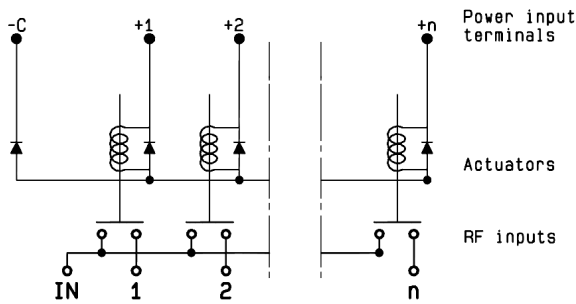

#### WITH SUPPRESSION DIODES & INDICATOR CONTACT

R573-1--3- / R574 -1- -3-

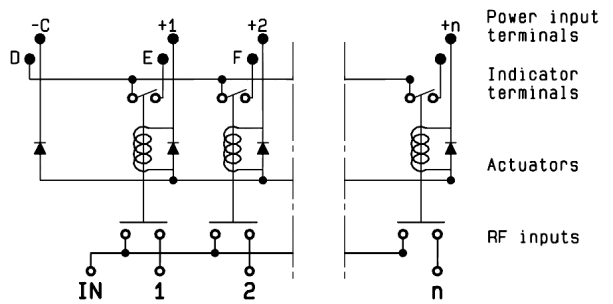

#### WITH TTL DRIVER (SUPPRESSION DIODES ARE INCLUDED)

R573-0--2- / R574 -0- -2-

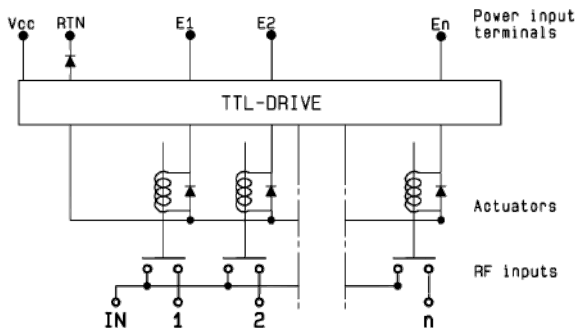

#### WITH TTL DRIVER & INDICATOR CONTACT

(SUPPRESSION DIODES ARE INCLUDED)

R573-1--2- / R574 -1- -2-

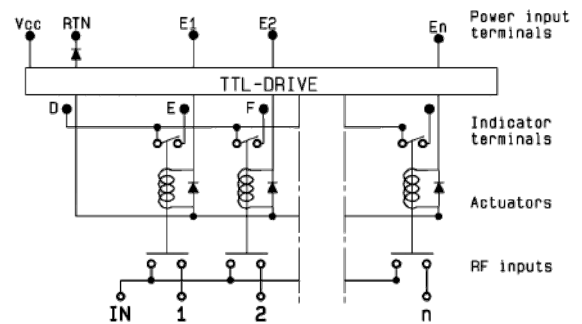



## COAXIAL SPNT - ELECTRICAL SCHEMATICS (CONTINUED)

### R573 - R574 SERIES

NORMALLY OPEN

WITH BCD DRIVER, TTL COMPATIBLE  
(SUPPRESSION DIODES ARE INCLUDED)  
R573-0--8- / R574-0--8-

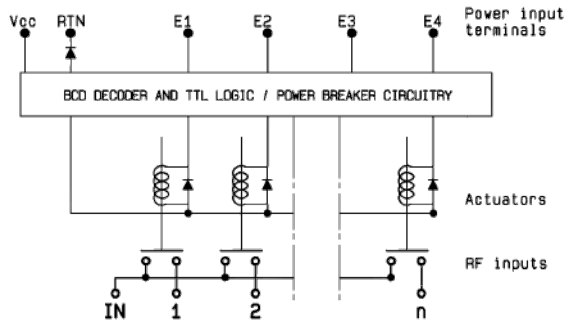

WITH BCD DRIVER, TTL COMPATIBLE & INDICATOR CONTACT  
(SUPPRESSION DIODES ARE INCLUDED)  
R573-1--8- / R574-1--8-

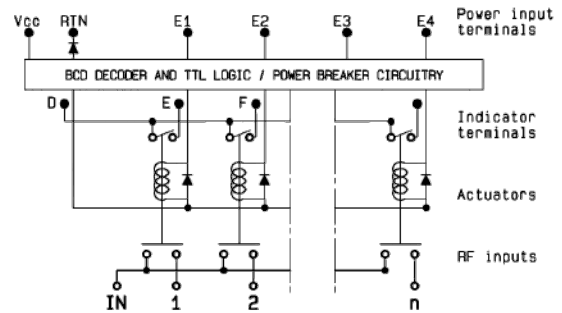

WITH POSITIVE COMMON  
R573-0--1- / R574-0--1-

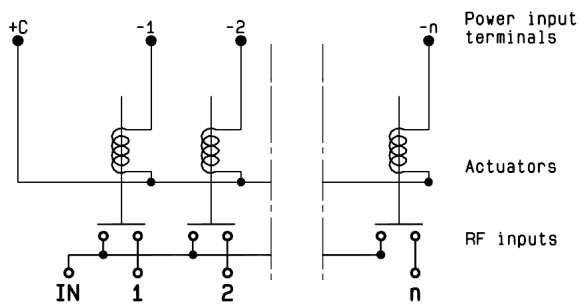

WITH POSITIVE COMMON AND INDICATOR CONTACT  
R573-1--1- / R574-1--1-

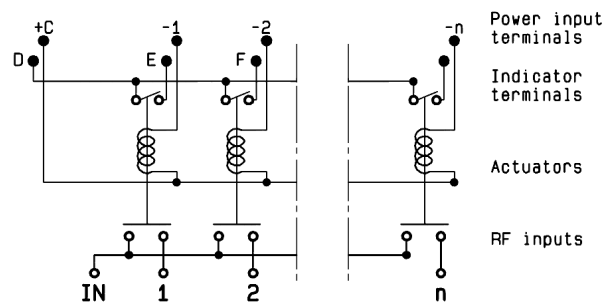

WITH POSITIVE COMMON AND SUPPRESSION DIODES  
R573-0--4- / R574-0--4-

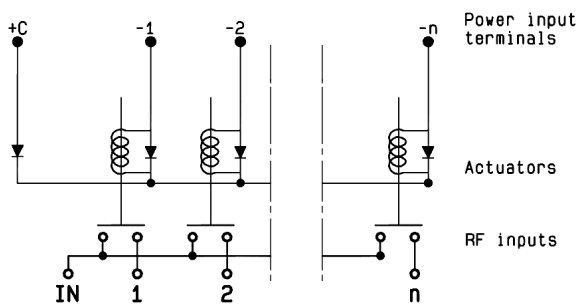

WITH POSITIVE COMMON, SUPPRESSION DIODES  
& INDICATOR CONTACT  
R573-1--4- / R574-1--4-

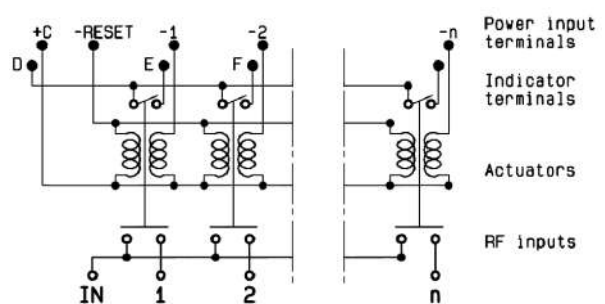

## COAXIAL SPNT - ELECTRICAL SCHEMATICS

### R573 - R574 SERIES

#### LATCHING

#### WITHOUT OPTION

R573-2--0- / R574-2--0-

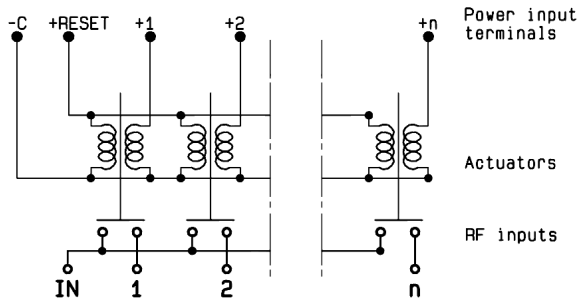

#### WITH INDICATOR CONTACT

R573-3--0- / R574-3--0-

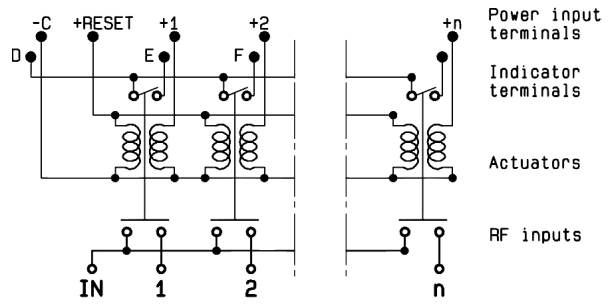

#### WITH SUPPRESSION DIODES

R573-2--3- / R574-2--3-

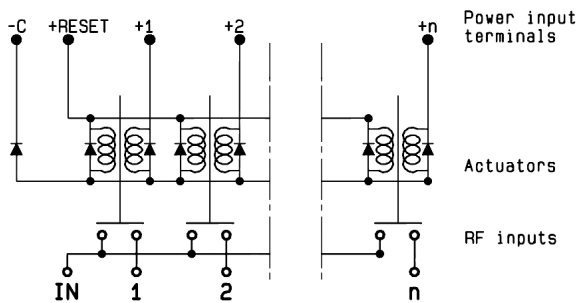

#### WITH SUPPRESSION DIODES AND INDICATOR CONTACT

R573-3--3- / R574-3--3-

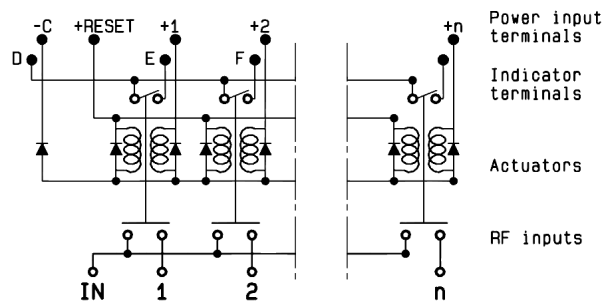

#### WITH TTL DRIVER (SUPPRESSION DIODES ARE INCLUDED)

R573-2--2- / R574-2--2-

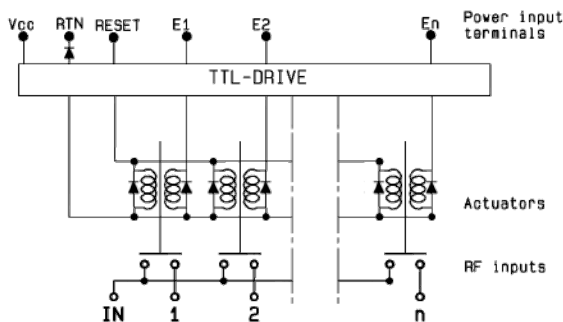

#### WITH TTL DRIVER & INDICATOR CONTACT (SUPPRESSION DIODES ARE INCLUDED)

R573-3--2- / R574-3--2-

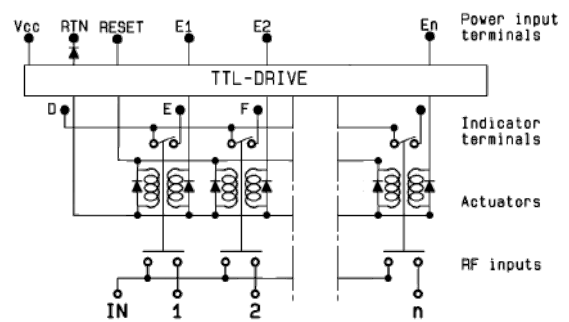

## COAXIAL SPNT - ELECTRICAL SCHEMATICS (CONTINUED)

### R573 - R574 SERIES

#### LATCHING

#### WITH CUT-OFF (SUPPRESSION DIODES ARE INCLUDED)

R573-4--0- / R574-4--0-

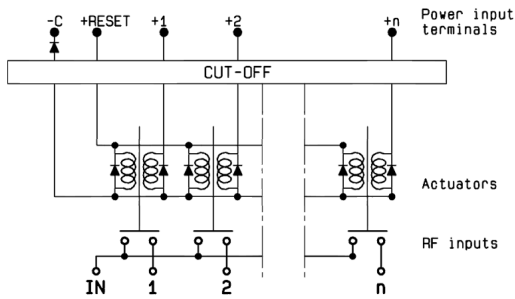

#### WITH CUT-OFF AND INDICATOR CONTACT (SUPPRESSION DIODES ARE INCLUDED)

R573-5--0- / R574-5--0-

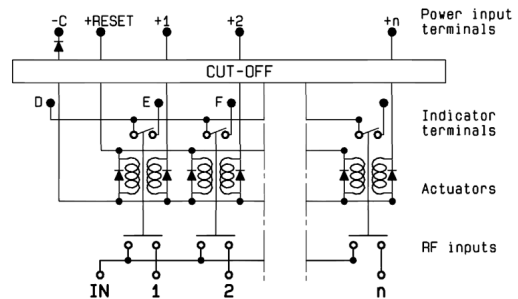

#### WITH CUT-OFF & AUTO REST (SUPPRESSION DIODES ARE INCLUDED)

R573-8--0- / R574-8--0-

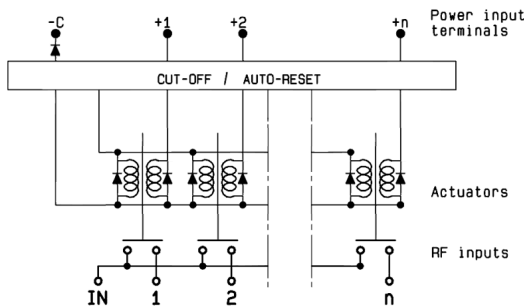

#### WITH CUT-OFF, AUTO REST & INDICATOR CONTACT (SUPPRESSION DIODES ARE INCLUDED)

R573-9--0- / R574-9--0-

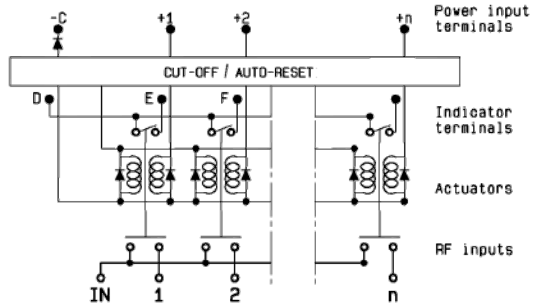

#### WITH TTL DRIVER AND CUT-OFF (SUPPRESSION DIODES ARE INCLUDED)

R573-4--2- / R574-4--2-

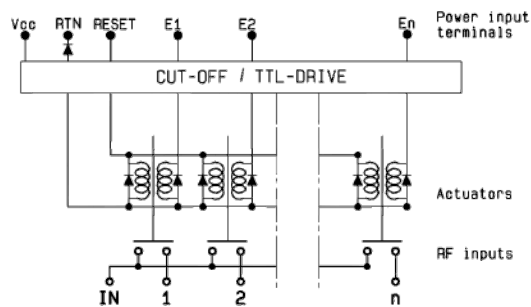

#### WITH TTL DRIVER, CUT-OFF & INDICATOR CONTACT (SUPPRESSION DIODES ARE INCLUDED)

R573-5--2- / R574-5--2-

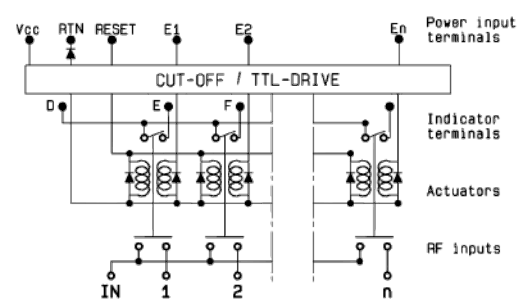

## COAXIAL SPNT - ELECTRICAL SCHEMATICS (CONTINUED)

### R573 - R574 SERIES

#### LATCHING

WITH TTL DRIVER, CUT-OFF & AUTO RESET  
(SUPPRESSION DIODES ARE INCLUDED)  
R573-8--2- / R574-8--2-

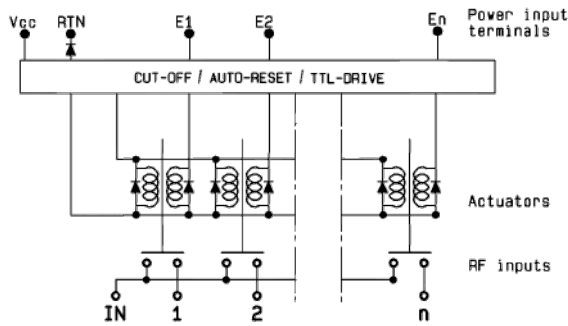

WITH TTL DRIVER, CUT-OFF, AUTO RESET & INDICATOR CONTACT  
(SUPPRESSION DIODES ARE INCLUDED)  
R573-9--2- / R574-9- -2-

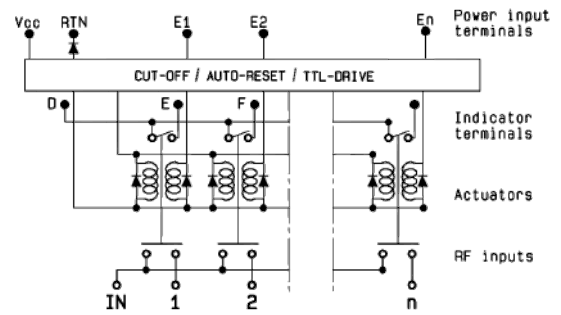

WITH CUT-OFF, FORCE OR AUTO RESET, BCD DRIVER, TTL COMPATIBLE  
(SUPPRESSION DIODES ARE INCLUDED)  
R573-8--8- / R574-8- -8-

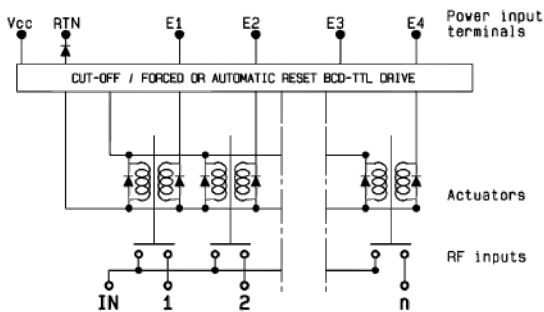

WITH CUT-OFF, FORCE OR AUTO RESET, BCD DRIVER, TTL COMPATIBLE & INDICATOR CONTACT  
(SUPPRESSION DIODES ARE INCLUDED)  
R573-9--8- / R574-9- -8-

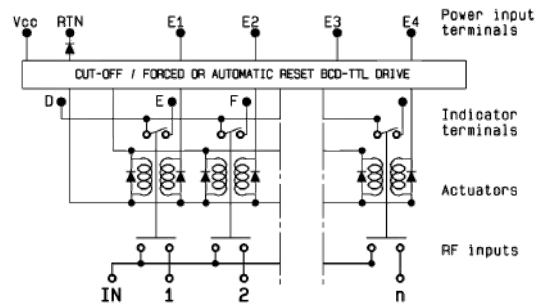

WITH POSITIVE COMMON  
R573-2--1- / R574-2- -1-

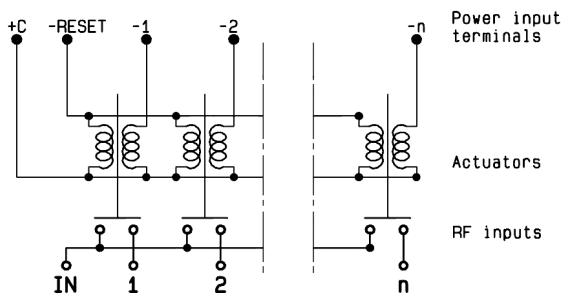

WITH POSITIVE COMMON & INDICATOR CONTACT  
(SUPPRESSION DIODES ARE INCLUDED)  
R573-3--1- / R574-3- -1-

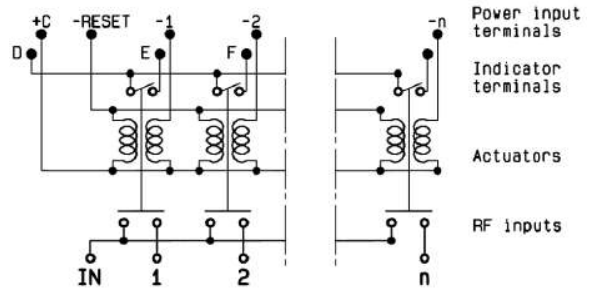

## COAXIAL SPNT - ELECTRICAL SCHEMATICS (CONTINUED)

### R573 - R574 SERIES

#### LATCHING

#### WITH POSITIVE COMMON & SUPPRESSION DIODES (SUPPRESSION DIODES ARE INCLUDED)

R573-2--4- / R574-2--4-

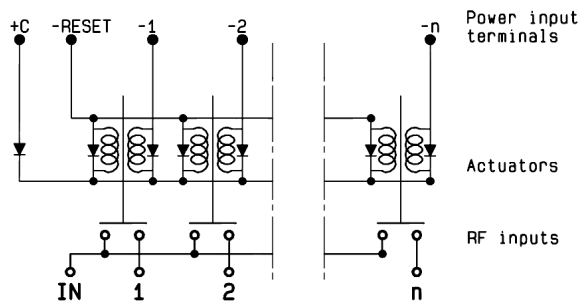

#### WITH POSITIVE COMMON, SUPPRESSION DIODES & INDICATOR CONTACT

R573-3--4- / R574-3--4-

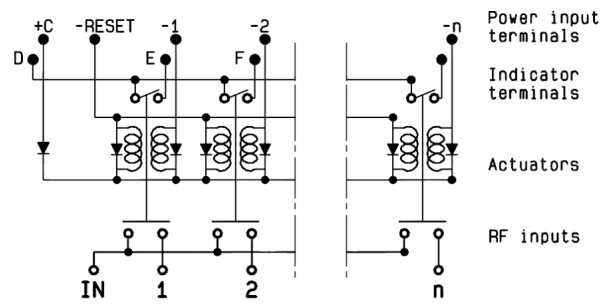

#### WITH POSITIVE COMMON, CUT-OFF, AUTO RESET

R573-8--1- / R574-8--1-

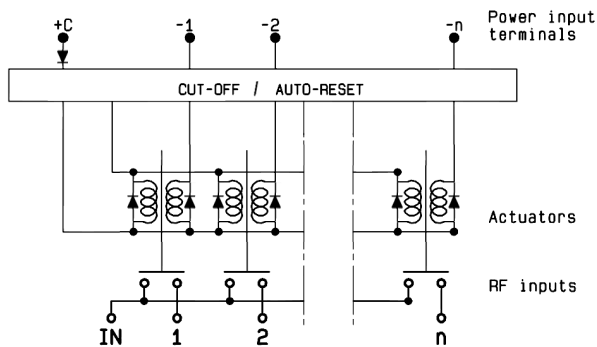

#### WITH POSITIVE COMMON, CUT-OFF, AUTO RESET & INDICATOR CONTACT

R573-9--1- / R574-9--1-

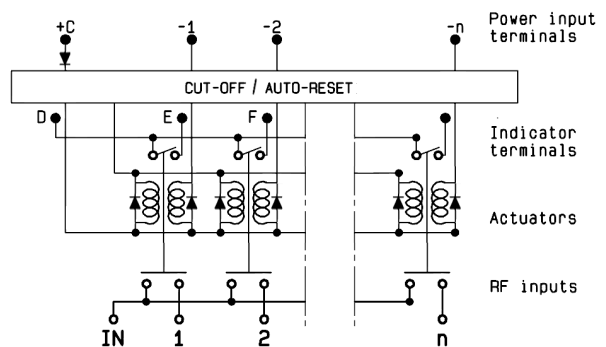

#### USB SERIES

#### NORMALLY OPEN WITH INDICATOR CONTACT

R573-11-01 / R574-11-01

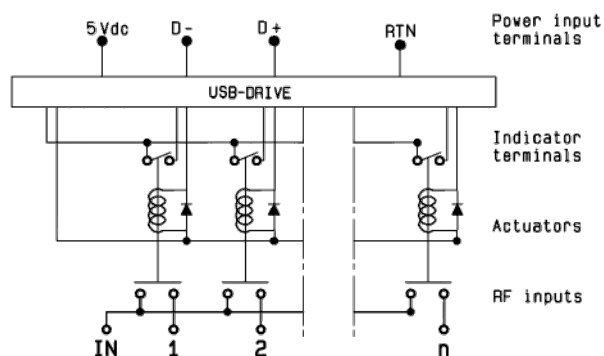

## HIGH PERFORMANCE MULTIPORT SWITCHES

### SPNT UP TO 40 GHz



Radiall's TITANIUM switches are optimized to perform at a high level over an extended life cycle. With outstanding RF performance, and a guaranteed insertion loss repeatability of 0.03 dB over a life span of 2.5 million switching cycles, Radiall's TITANIUM switches are a perfect solution for automated test and measurement equipment, as well as signal monitoring devices.

*Example of P/N: R514F73617 is a SP6T SMA up to 26.5 GHz, Latching, Indicators, Self cut-off, Auto-Reset, 24 Vdc and HE10 receptacle.*

#### PART NUMBER SELECTION

**R51**

##### SERIES PREFIX

##### MODEL

- 3: Without 50 Ω termination
- 4: With 50 Ω termination

##### RF CONNECTORS

- 3: SMA up to 6 GHz
- 4: SMA up to 20 GHz
- F: SMA up to 26.5 GHz
- 8: SMA 2.9 up to 40 GHz<sup>[1]</sup>

##### TYPE

- 7: Latching + Self cut-off + Auto Reset + Indicators

##### ACTUATOR VOLTAGE

- 3: 24 Vdc

##### NUMBER OF POSITIONS

- 4: 4 positions
- 6: 6 positions

##### OPTIONS\*

- 1: Positive common (without TTL)
- 2: TTL/5 V logic with 24 Vdc supply<sup>[2]</sup>

##### ACTUATOR TERMINAL

- 7: HE 10 receptacle, delivered with 750 mm (30 inches) ribbon cable + HE10 connector

##### DOCUMENTATION

- : Certificate of conformity
- C: Calibration certificate
- R: Calibration certificate + RF curves

#### Notes

1. Connector SMA 2.9 is equivalent to "K connector®", registered trademark of Anritsu.
2. Polarity is not relevant to application for switches with TTL driver

## Titanium Series

## GENERAL SPECIFICATIONS

OPERATING MODE		LATCHING	
Nominal operating voltage (across operating temperature)	Vdc	24 (20/32)	
Coil resistance (+/-10%)	$\Omega$	120	
Operating current at 23 °C	mA	200	
Maximum stand-by current	mA	50	
Average power Terminated Model	All models	RF path Cold switching: See Power page 5-50 Hot switching: 1 Watt Cw	
		Internal terminations 1 Watt average into 50 $\Omega$	
TTL input	High level	3 to 7 V	1.4 mA max at Vcc = Max
	Low level	0 to 0.8 Volts	-
Indicator specifications		Maximum withstanding voltage	60 V
		Maximum current capacity	150 mA
		Maximum "ON" resistance	2.5 $\Omega$
		Minimum "OFF" resistance	100 M $\Omega$
Switching time (max)	ms	15	
Life (min)	SMA	2.5 million cycles	
	SMA 2.9	1 million cycles	
Connectors		SMA - SMA 2.9	
Actuator terminals		HE10 ribbon receptacle	
Weight (max)	g	230	

## ENVIRONMENTAL SPECIFICATIONS

Operating temperature range	-25 °C to +75 °C
Storage temperature range	-55 °C to +85 °C
Temperature cycling (MIL-STD-202, Method 107D, Cond.A)	-55 °C to +85 °C (10 cycles)
Vibration (MIL STD 202, Method 204D, Cond.D)	10 - 2,000 Hz, 10 g - operating
Shock (MIL STD 202, Method 213B, Cond.C)	50 g/6 ms, 1/2 sine - operating
Moisture resistance (MIL STD 202, Method 106E, Cond.E)	65 °C, 95% RH, 10 days
Altitude storage (MIL STD 202, Method 105C, Cond.B)	50,000 ft (15,240 meters)
RFI (MIL STD 1344, Method 3008 or IEC 61726)	55 dB at 20 GHz
Magnetic field	< 5.10-5 gauss at 1 meter

Titanium Series

RF PERFORMANCE

PART NUMBER		R51-3-34-7 R51-3-36-7	R51-4-34-7 R51-4-36-7	R51-F-34-7 R51-F-36-7	R51-8-34-7 R51-8-36-7			
Frequency Range	GHz	DC to 6	DC to 20	DC to 26.5	DC to 40			
Impedance	Ω	50						
Insertion Loss (max)	dB	0.3 + 0.015 × frequency (GHz)						
Isolation (min)	dB	80	DC to 6 GHz	80	DC to 6 GHz	80	DC to 6 GHz	80
			6 to 12.4 GHz	70	6 to 12.4 GHz	70	6 to 12.4 GHz	70
			12.4 to 20 GHz	65	12.4 to 20 GHz	65	12.4 to 18 GHz	65
			-	-	20 to 26.5 GHz	60	18 to 26.5 GHz	60
V.S.W.R. (max)		1.20	DC to 6 GHz	1.20	DC to 6 GHz	1.20	DC to 6 GHz	1.20
			6 to 12.4 GHz	1.35	6 to 12.4 GHz	1.35	6 to 12.4 GHz	1.35
			12.4 to 20 GHz	1.45	12.4 to 20 GHz	1.45	12.4 to 18 GHz	1.45
			-	-	20 to 26.5 GHz	1.70	18 to 26.5 GHz	1.70
			-	-	-	-	26.5 to 40 GHz	1.90
Third order inter Modulation		- 120 dBC typical (2 carriers 20w)						
Repeatability (measured at 25 °C)		0.03 dB		0.05 dB				

TYPICAL RF PERFORMANCE

INSERTION LOSS & ISOLATION

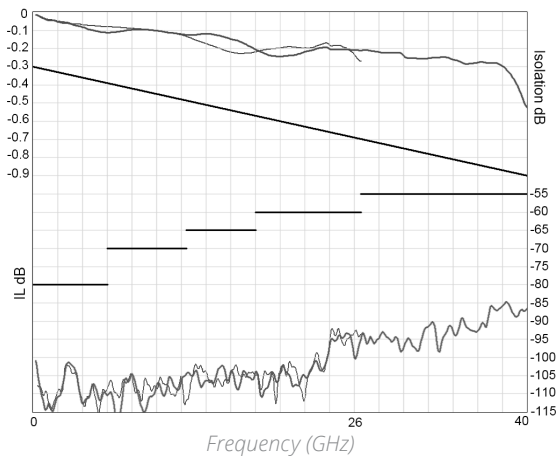

V.S.W.R

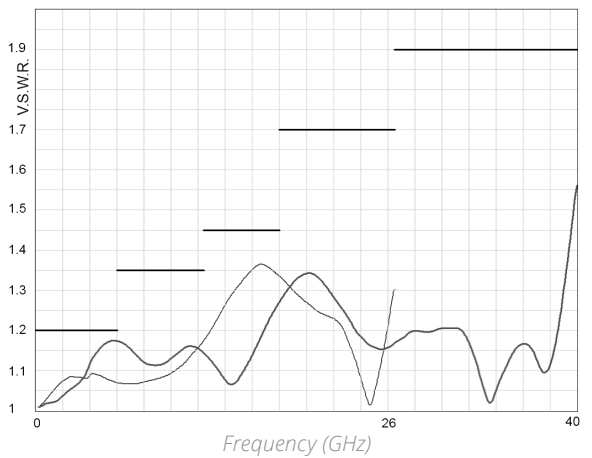

SMA — SMA 2.9 —



**ELECTRONIC POSITION INDICATORS**

The electronic position indicators use photo-MOS transistors, which are driven by the mechanical position of the RF paths moving elements. The circuitry consists of a common which can be connected to an output corresponding to a selected RF path. If one or several RF paths are closed, the corresponding indicators are connected to the common. The photo-MOS transistors are configured for AC and/or DC operation. The electronic position indicators require the supply (20 to 32 VDC) to be connected to pin 1 and ground connected to pin 15.

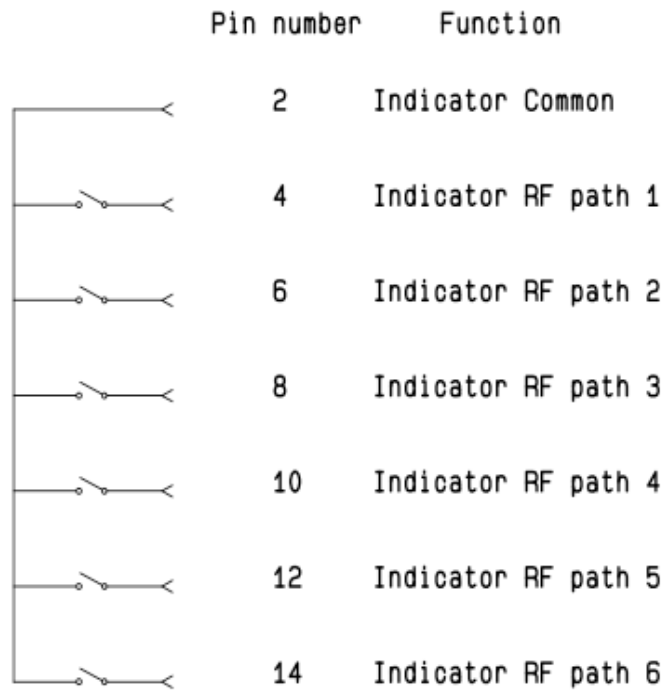

**Notes**

Ways 1 and 4 are not connected for SP4T switches.

**TYPE 7: WITH TTL (OPTION "2") / WITHOUT TTL (OPTION "1") & INDICATORS**

Each RF path can be closed by applying ground or TTL "High" for option 2 to the corresponding "drive" pin. In general, except for Make-Before-Break drive, all other RF paths are simultaneously opened by internal logic.

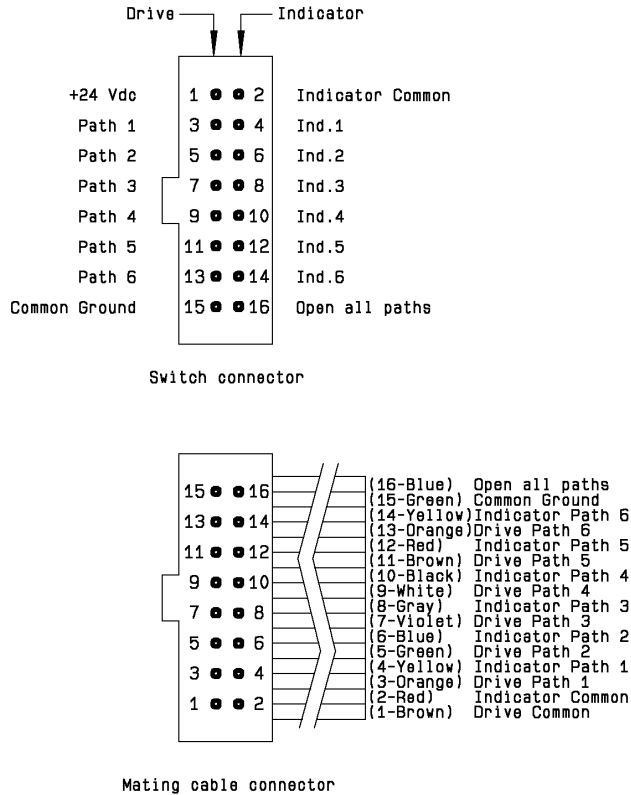

**Standard drive option "1":**

- Connect pin 15 to ground
- Connect pin 1 to supply (+20 VDC to +32 VDC)
- Select (close) desired RF path by applying ground to the corresponding "drive" pin (Ex: apply ground to pin 3 to close RF path 1)
- To select another path, ensure that all unwanted RF path "drive" pins are disconnected from ground (to prevent multiple RF path engagement), then apply ground to the "drive" pin which corresponds to the desired RF path
- To open all RF paths, ensure that all RF path "drive" pins are disconnected from ground. Complete the operation by applying ground to pin 16

**TTL drive option "2":**

- Connect pin 15 to ground
- Connect pin 1 to supply (+20 VDC to +32 VDC)
- Select (close) desired RF path by applying TTL "High" to the corresponding "drive" pin (Ex: apply TTL "High" to pin 3 to close RF path 1)
- To select another path, ensure that all unwanted RF path "drive" pins are in TTL "low" position (to prevent multiple RF path engagement), then apply TTL "high" to the "drive" pin which corresponds to the desired RF path
- To open all RF paths, ensure that all RF path "drive" pins are in TTL "Low" position. Complete the operation by applying TTL "High" to pin 16

**Break-Before-Make:**

Open the undesired RF path for at least 15 minutes (minimum), then close the new RF port

**Make-Before-Break:**

Ensure that the previously selected RF path "drive" is connected to ground (or TTL "High" for option "2"), then close the new RF path

**Notes**

Ways 1 and 4 are not connected for SP4T switches.

Titanium Series

TYPICAL OUTLINE DRAWING

SMA CONNECTORS

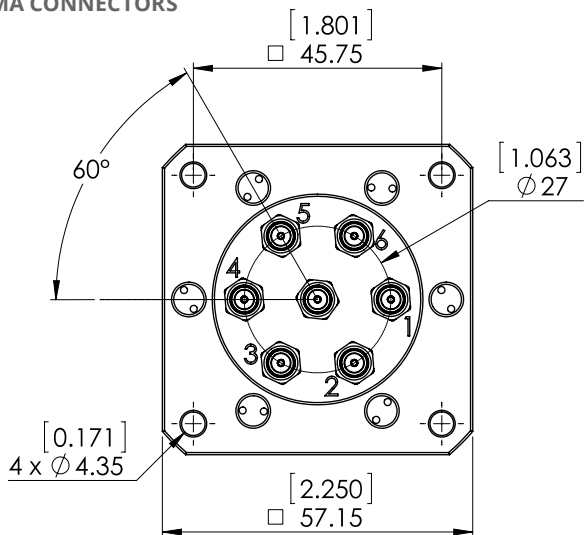

SMA 2.9 CONNECTORS

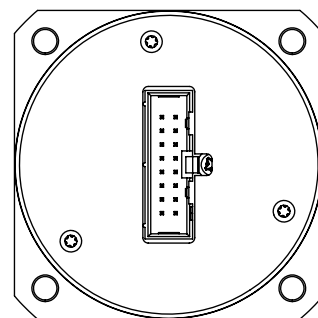
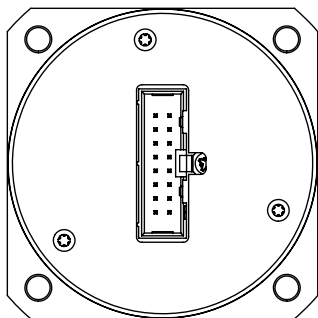
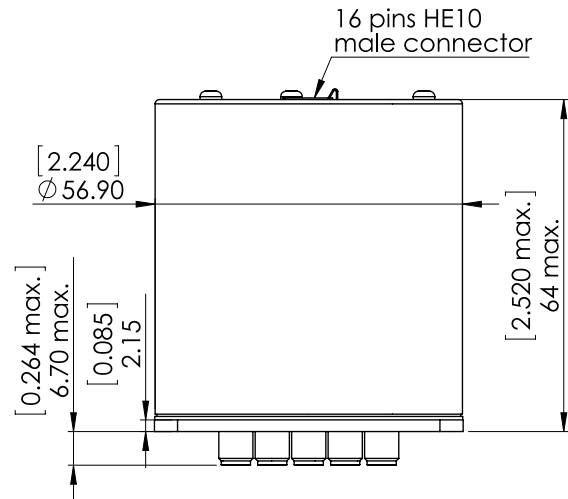
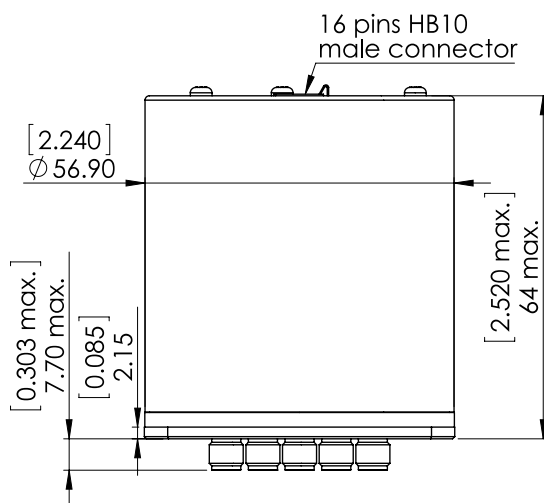
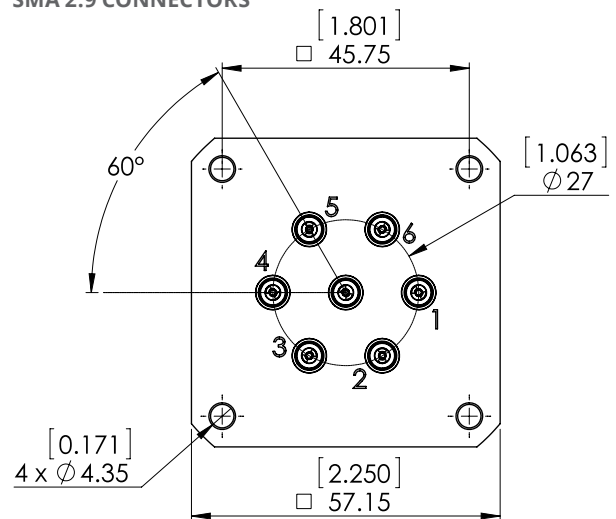

Notes

All dimensions are in millimeters [inches].  
 Ways 1 and 4 are not connected for SP4T switches.

**POWER RATING CHART**

This graph is based on the following conditions:

- Ambient temperature: + 25 °C
- Sea level
- V.S.W.R.: 1 and cold switching

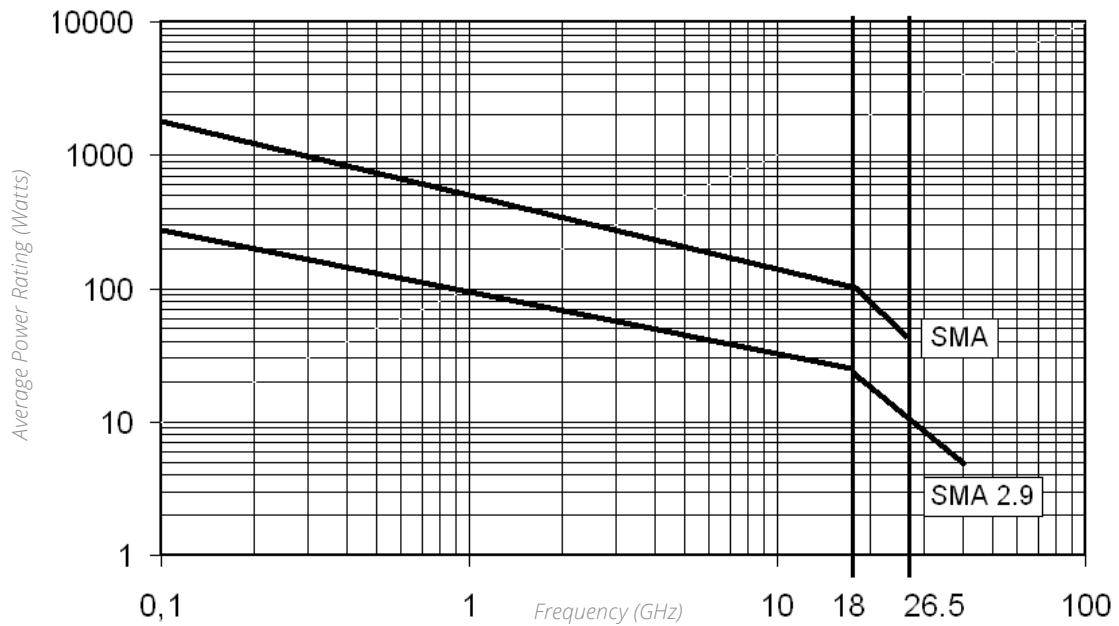

**DERATING FACTOR VERSUS VSWR**

The average power input must be reduced for load V.S.W.R. above 1:1.

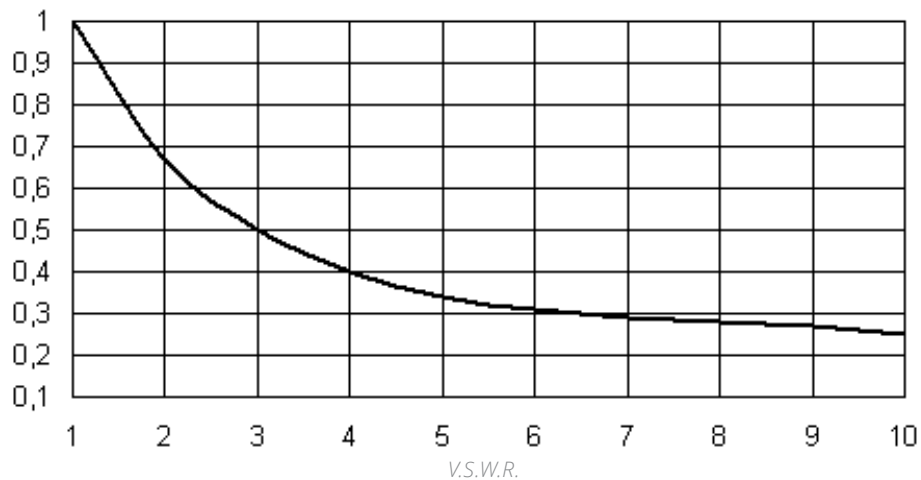

**Notes**

Ways 1 and 4 are not connected for SP4T switches.

Platinum Series

## HIGH PERFORMANCE MULTIPORT SWITCHES

SPNT TERMINATED UP TO 40 GHz



Radiall's PLATINUM series switches are optimized to perform at a high level over an extended life cycle. With outstanding RF performance, and a guaranteed insertion loss repeatability of 0.03 dB over a life span of 10 million switching cycles, Radiall's PLATINUM series switches are a perfect solution for automated test and measurement equipment, as well as signal monitoring devices.

*Example of P/N: R594873427 is a SPnT SMA 2.9 up to 40 GHz, Latching with Indicators, Self cut-off, Auto-Reset, TTL driver and HE10 connector.*

### PART NUMBER SELECTION

R594

**SERIES PREFIX** \_\_\_\_\_

**RF CONNECTORS** \_\_\_\_\_

- 3: SMA up to 6 GHz
- 4: SMA up to 20 GHz
- F: SMA up to 26.5 GHz
- 8: SMA 2.9 up to 40 GHz<sup>[1]</sup>

**TYPE** \_\_\_\_\_

- 4: Latching + Self cut-off without indicator
- 7: Latching + Self cut-off + Auto Reset + Indicators

**ACTUATOR VOLTAGE** \_\_\_\_\_

- 3: 24 Vdc

**NUMBER OF POSITIONS** \_\_\_\_\_

- 4: 4 positions
- 6: 6 positions

**OPTIONS** \_\_\_\_\_

- 1: Positive common (without TTL)
- 2: TTL/5 V logic with 24 Vdc supply<sup>[2 & 3]</sup>

**ACTUATOR TERMINAL** \_\_\_\_\_

- 7: HE 10 receptacle, delivered with 750 mm (30 inches) ribbon cable + HE10 connector

**DOCUMENTATION** \_\_\_\_\_

- : Certificate of conformity
- C: Calibration certificate
- R: Calibration certificate + RF curves

**Notes**

- Ways 1 and 4 are not connected for SP4T switches.
- 1. Connector SMA 2.9 is equivalent to "K connector", registered trademark of Anritsu
- 2. Polarity is not relevant to application for switches with TTL driver
- 3. Only available with type "7"

## Platinum Series

## GENERAL SPECIFICATIONS

OPERATING MODE		LATCHING	
Nominal operating voltage (across operating temperature)	Vdc	24 (20/32)	
Coil resistance (+/-10%)	$\Omega$	120	
Operating current at 23 °C	mA	200	
Maximum stand-by current	mA	50	
Average power		RF path Cold switching: See Power page 5-59 Hot switching: 1 Watt Cw	
		Internal terminations 1 Watt average into 50 $\Omega$	
TTL input	High level	3 to 7 V	1.4 mA max at Vcc = Max
	Low level	0 to 0.8 Volts	-
Indicator specifications		Maximum withstanding voltage	60 V
		Maximum current capacity	150 mA
		Maximum "ON" resistance	2.5 $\Omega$
		Minimum "OFF" resistance	100 M $\Omega$
Switching time (max)	ms	15	
Life (min)	SMA	10 million cycles	
	SMA 2.9	2.5 million cycles	
Connectors		SMA - SMA 2.9	
Actuator terminals		HE10 ribbon receptacle	
Weight (max)	g	230	

## ENVIRONMENTAL SPECIFICATIONS

Operating temperature range	-25 °C to +75 °C
Storage temperature range	-55 °C to +85 °C
Temperature cycling (MIL-STD-202, Method 107D, Cond.A)	-55 °C to +85 °C (10 cycles)
Vibration (MIL STD 202, Method 204D, Cond.D)	10 - 2,000 Hz, 10 g - operating
Shock (MIL STD 202, Method 213B, Cond.C)	50 g/6 ms, 1/2 sine - operating
Moisture resistance (MIL STD 202, Method 106E, Cond.E)	65 °C, 95% RH, 10 days
Altitude storage (MIL STD 202, Method 105C, Cond.B)	50,000 ft (15,240 meters)
RFI (MIL STD 1344, Method 3008 or IEC 61726)	55 dB at 20 GHz
Magnetic field	< 5.10-5 gauss at 1 meter

Platinum Series

RF PERFORMANCE

PART NUMBER		R5943-34-7	R5944-34-7 R5944-36-7	R594F-34-7 R594F-36-7	R5948-34-7 R5948-36-7			
Frequency Range	GHz	DC to 6	DC to 20	DC to 26.5	DC to 40			
Impedance	Ω	50						
Insertion Loss (max)	dB	0.3 + 0.015 × frequency (GHz)						
Isolation (min)	dB	100	DC to 6 GHz	100	DC to 6 GHz	100	DC to 6 GHz	100
			6 to 12.4 GHz	90	6 to 12.4 GHz	90	6 to 12.4 GHz	90
			12.4 to 20 GHz	80	12.4 to 20 GHz	80	12.4 to 18 GHz	80
			-	-	20 to 26.5 GHz	70	18 to 26.5 GHz	70
			-	-	-	-	26.5 to 40 GHz	60
V.S.W.R. (max)		1.20	DC to 6 GHz	1.20	DC to 6 GHz	1.20	DC to 6 GHz	1.20
			6 to 12.4 GHz	1.35	6 to 12.4 GHz	1.35	6 to 12.4 GHz	1.35
			12.4 to 20 GHz	1.45	12.4 to 20 GHz	1.45	12.4 to 18 GHz	1.45
			-	-	20 to 26.5 GHz	1.70	18 to 26.5 GHz	1.70
			-	-	-	-	26.5 to 40 GHz	1.90
Repeatability (measured at 25 °C)		0.03 dB			0.05 dB			

TYPICAL RF PERFORMANCE

INSERTION LOSS & ISOLATION

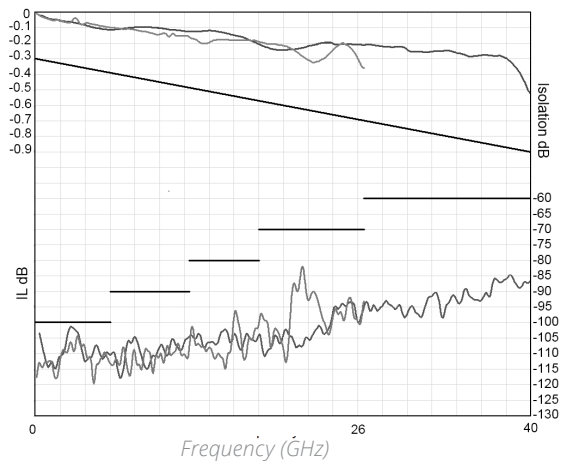

V.S.W.R

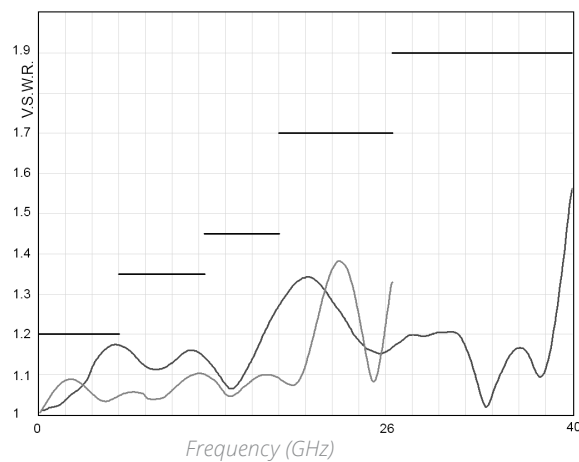

SMA — SMA 2.9 —

**ELECTRONIC POSITION INDICATORS**

*(This option is not available with type 4)*

The electronic position indicators use photo-MOS transistors, which are driven by the mechanical position of the RF paths moving elements. The circuitry consists of a common which can be connected to an output corresponding to selected RF path. If one or several RF paths are closed, the corresponding indicators are connected to the common. The photo-MOS transistors are configured for AC and/or DC operation. The electronic position indicators require the supply (20 to 32 VDC) to be connected to pin 1 and ground connected to pin 15.

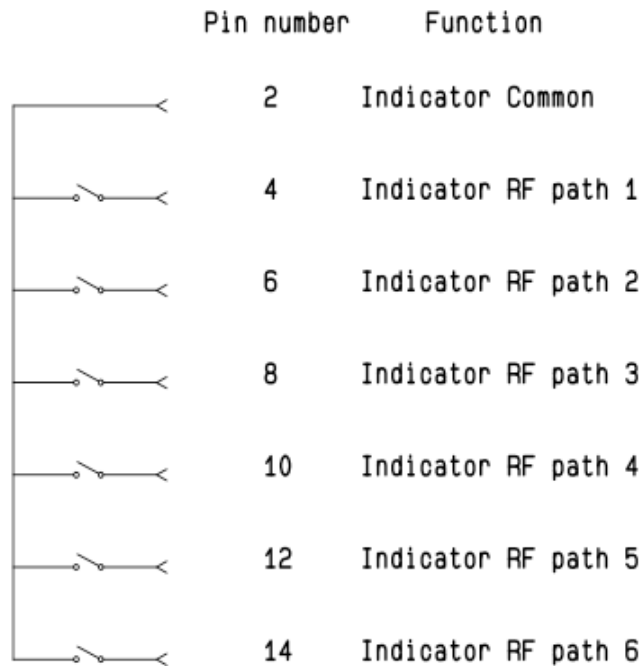

**Notes**

Ways 1 and 4 are not connected for SP4T switches.



### DRIVING THE SWITCH

Each RF path is driven independently, and can be closed or open by applying ground to the corresponding "open" or "close" pin.

#### TYPE 4: WITHOUT TTL AND WITHOUT INDICATOR

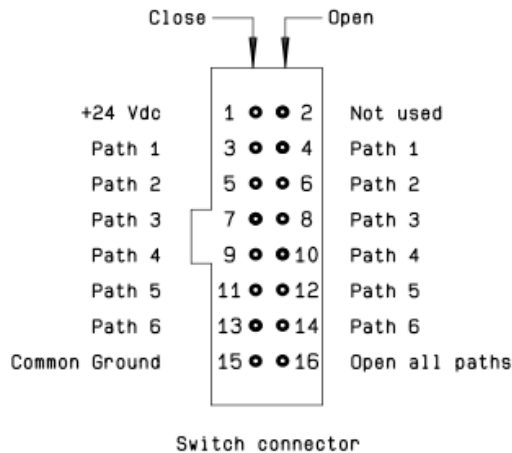

#### Standard drive:

- Connect pin 15 to ground
- Connect pin 1 to supply (+20 VDC to +32 VDC)
- Select desired RF path by applying ground to the corresponding "close" pin (Ex: ground pin 3 to close RF path 1)
- To open desired RF path connect ground to the corresponding "open" pin (Ex: ground pin 4 to open RF path 1)
- To open all RF paths, first ensure that all RF path "close" pins are disconnected from ground, then to complete the operation, connect pin 16 to ground

#### Make-Before-Break:

Make-Before-Break switching can be accomplished by closing the new RF path before opening the previously selected RF path. To complete the operation, close the new RF port for at least 15 minutes (minimum), then open the previously selected RF port.

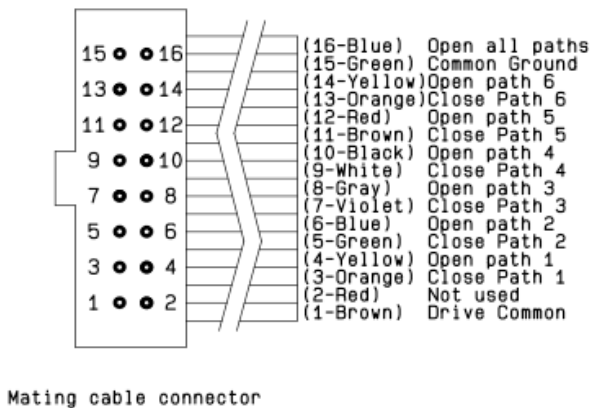

#### Notes

Ways 1 and 4 are not connected for SP4T switches.

**TYPE 7: WITH TTL (OPTION "2") / WITHOUT TTL (OPTION "1") & INDICATORS**

Each RF path can be closed by applying Ground or TTL "High" for option 2 to the corresponding "drive" pin. In general, except for Make-Before-Break drive, all other RF paths are simultaneously opened by internal logic.

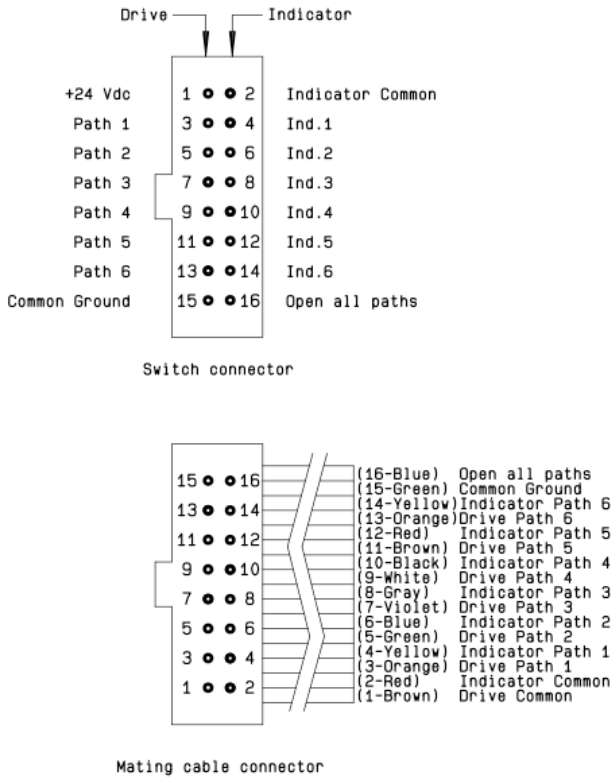

**Standard drive option "1":**

- Connect pin 15 to ground
- Connect pin 1 to supply (+20 VDC to +32 VDC)
- Select (close) desired RF path by applying ground to the corresponding "drive" pin (Ex: apply ground to pin 3 to close RF path 1)
- To select another path, ensure that all unwanted RF path "drive" pins are disconnected from ground (to prevent multiple RF path engagement), then apply ground to the "drive" pin which corresponds to the desired RF path
- To open all RF paths, ensure that all RF path "drive" pins are disconnected from ground, then complete the operation by applying ground to pin 16

**TTL drive option "2":**

- Connect pin 15 to ground
- Connect pin 1 to supply (+20 VDC to +32 VDC)
- Select (close) desired RF path by applying TTL "High" to the corresponding "drive" pin (Ex: apply TTL "High" to pin 3 to close RF path 1)
- To select another path, ensure that all unwanted RF path "drive" pins are in TTL "Low" position (to prevent multiple RF path engagement), then apply TTL "High" to the "drive" pin which corresponds to the desired RF path
- To open all RF paths, ensure that all RF path "drive" pins are in TTL "Low" position, then complete the operation by applying TTL "High" to pin 16

**Break-Before-Make:**

Open the undesired RF path after 15 minutes (minimum), then close the new RF port.

**Make-Before-Break:**

Ensure that the previously selected RF path "drive" is connected to ground (or TTL "High" for option "2"), then close the new RF path.

**Notes**

Ways 1 and 4 are not connected for SP4T switches.

Platinum Series

TYPICAL OUTLINE DRAWING

SMA CONNECTORS

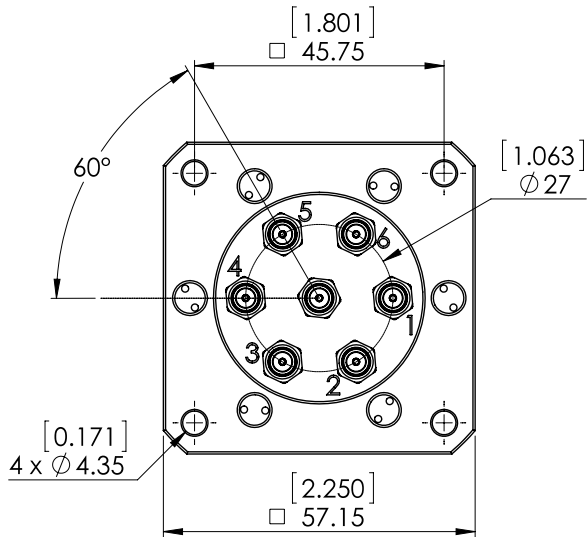

SMA 2.9 CONNECTORS

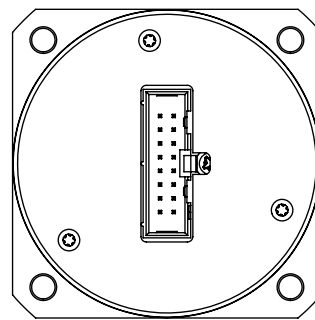
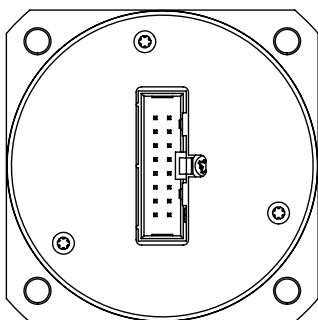
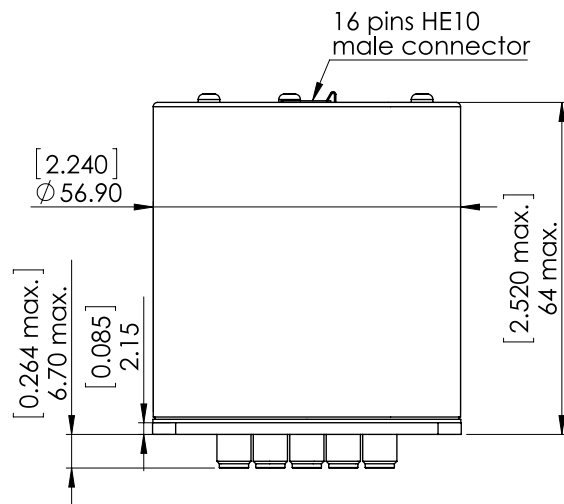
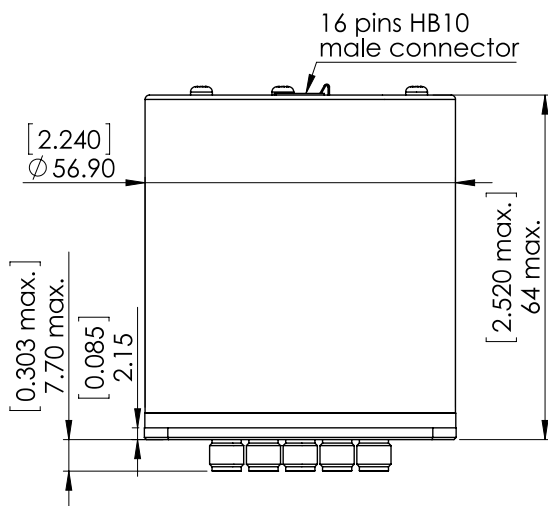
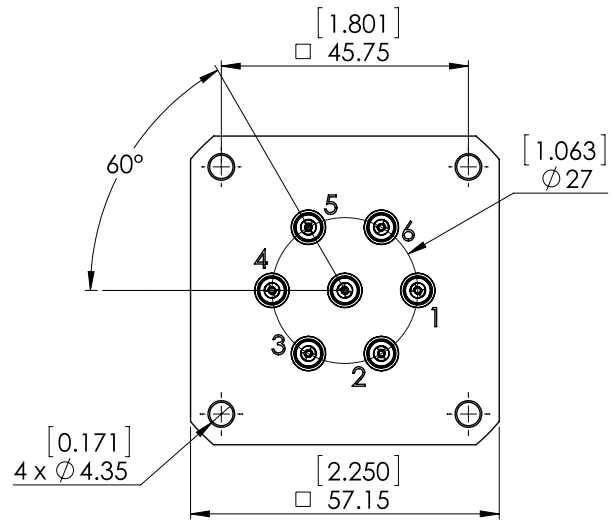

Notes

All dimensions are in millimeters [inches]. Ways 1 and 4 are not connected for SP4T switches.

**POWER RATING CHART**

This graph is based on the following conditions:

- Ambient temperature: + 25 °C
- Sea level
- V.S.W.R.: 1 and cold switching

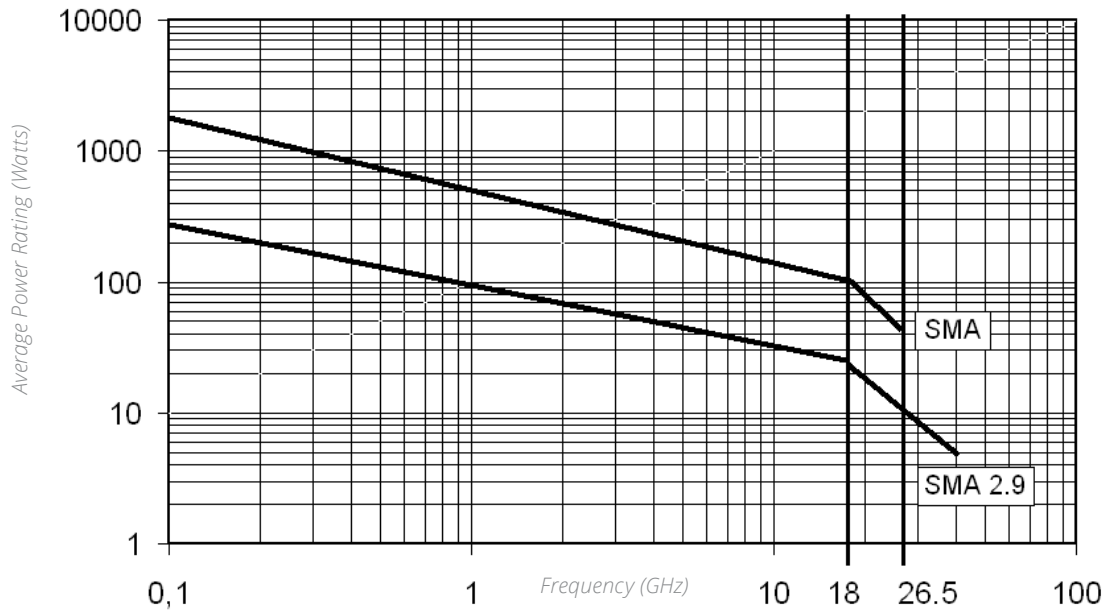

**DERATING FACTOR VERSUS VSWR**

The average power input must be reduced for load V.S.W.R. above 1:1.

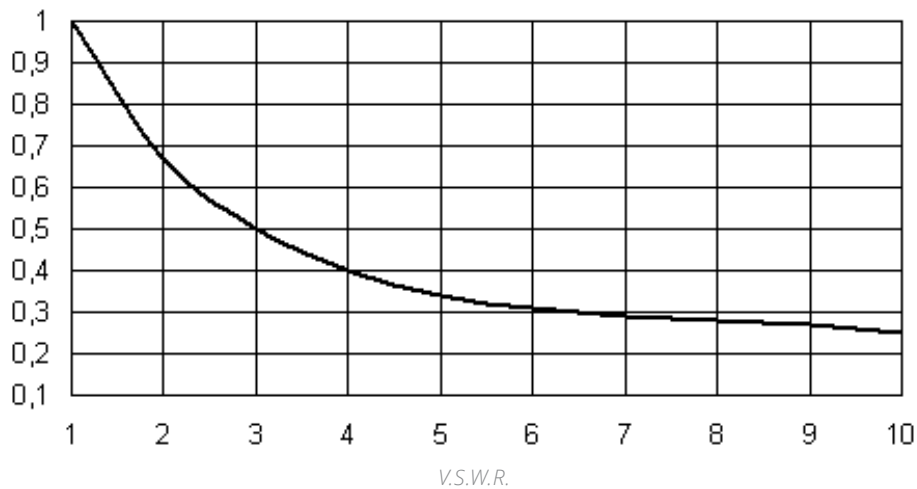

Optional Features

**OPTIONAL FEATURES**

**EXAMPLES OF DEDICATED APPLICATION OPTIONS**



SPnT with flat ribbon cable for easy installation with limited space.



Thermal vacuum SPnT up to 50 GHz designed based on our expertise in Space. For more detailed information, see page 7-18 to 7-20.



SPnT models can be fitted with external loads (up to 50 GHz) for an easy maintenance of equipment.



7P6T switch for a Custom Matrix Switch ( 4P3T ) with 4 Input ports and 4 Output ports configured for 3 transmission systems and one redundancy channel (N+1: N type) for example.



SP3T used for a military application with sequential access and severe environmental characteristics.



Unterminated SP3-6T with 9 pins D-sub connector instead of solder pins.

Notes



## LOW PIM

---





Section 6 Table of Contents

**RAMSES SERIES**

SPDT up to 18 GHz: R570xxxxxLP Series .....6-2 to 6-6  
 DPDT up to 18 GHz: R577xxxxxLP Series ..... 6-7 to 6-11  
 SPnT up to 18 GHz: R573xxxxxLP Series..... 6-12 to 6-15  
 Coaxial Low PIM Switches - Electrical Schematics ..... 6-16

**LOW PIM PART NUMBER SELECTION GUIDE<sup>[1]</sup>**

DIGITAL POSITION		R 1-3:	4: RF CONNECTORS		5: TYPE			6: VOLTAGE		7: TTL		8: OPTIONS				9: TERMINALS	
Series	Configuration		N 12.4 GHz	SMA 18 GHz	Failsafe	Latching	Normally open <sup>(1)</sup>	12 V	28 V	Without TTL	With TTL	Without option	Positive common	Suppression diodes	Positive common and suppression diodes	Solder pins	D-Sub connector
RAMSES	SPDT	R570LP	1	4	0/1	2/3/5/6	-	2	3	0	1	0	1	3	4	0	5
	DPDT	R577LP	1	4	0/1	2/3/5/6	-	2	3	0	1	0	1	3	4	0	5

DIGITAL POSITION		R 1-3:	4: RF CONNECTORS		5: TYPE			6: VOLTAGE		7: POS.		8: OPTIONS				9: TERMINALS		
Series	Configuration		N 12.4 GHz	SMA 18 GHz	Failsafe	Latching	Normally open <sup>(1)</sup>	12 V	28 V	Number of positions	With TTL	Without option	Positive common	TTL Driver	Suppression diodes	Positive common and suppression diodes	Solder pins	D-Sub connector
RAMSES	SPnT	R573LP	1	4	-	2/3/4/5/8/9	0/1	2	3	4/6		0	1	2	3	4	0	5

**Notes**

Example of P/N: R573423600LP is a SP6T SMA 18 GHz, latching, 28 Vdc, without option, solder pins.  
 1. For part number creation and available options, see detailed part number selection for each series.

### SPDT LOW PIM UP TO 18 GHz



To meet growing market demands created by the deployment of 4G/LTE networks, Radiall has introduced a new range of Low PIM switches. RAMSES SPDT Low PIM switches are perfectly suited for RF test systems and test benches requiring excellent passive intermodulation performance up to 18 GHz; with a guarantee PIM performance of -160 dBc at +43 dBm over a life span of 2 million switching cycles. These products are specific to instrumentation and telecommunication applications.

Example of P/N: R570413030LP is a SPDT Low PIM SMA 18 GHz, failsafe, 28 Vdc, with suppression diodes, solder pins.

#### PART NUMBER SELECTION

SERIES PREFIX \_\_\_\_\_

FREQUENCY RANGE \_\_\_\_\_

- 1: N up to 12.4 GHz
- 4: SMA up to 18 GHz

TYPE \_\_\_\_\_

- 1: Failsafe
- 2: Failsafe + I.C.
- 3: Latching
- 4: Latching + I.C.
- 5: Latching + S.C.O. <sup>[1]</sup>
- 6: Latching + S.C.O. + I.C. <sup>[1]</sup>

ACTUATOR VOLTAGE \_\_\_\_\_

- 2: 12 Vdc
- 3: 28 Vdc

TTL OPTION \_\_\_\_\_

- 0: Without TTL driver
- 1: With TTL driver <sup>[1 & 3]</sup>

OPTIONS<sup>[5]</sup> \_\_\_\_\_

- 0: Without option
- 1: Positive common <sup>[2]</sup>
- 3: With suppression diodes
- 4: With suppression diodes and positive common <sup>[2]</sup>

ACTUATOR TERMINALS \_\_\_\_\_

- 0: Solder pins
- 5: D-Sub connector <sup>[4]</sup>

R570

LP

#### Notes

I.C.: Indicator contact - S.C.O.: Self Cut-Off

1. Suppression diodes are already included in Self Cut-Off & TTL option
2. Positive common shall be specified only with type 3, 4, 5 & 6 because failsafe models can be used with both polarities
3. Polarity is not relevant to application for switches with TTL driver
4. Only available for N models

RAMSES Series

GENERAL SPECIFICATIONS

OPERATING MODE		FAILSAFE		LATCHING		
Nominal operating voltage (across operating temperature)		Vdc	12 (10.2 to 13)	28 (24 to 30)	12 (10.2 to 13)	28 (24 to 30)
Coil resistance at 23 °C (+/- 10%)	SMA	Ω	47.5	275	58	350
	N		38	200	38	225
Operating current at 23 °C	SMA	mA	250	102	210	80
	N		320	140	320	125
Average power		See Power Rating Chart on page 1-16				
TTL input		High level	2.2 to 5.5 V (TTL Option )/3.5 to 5.5 V ( BCD Option)			
		Low level	0 to 0.8 V (TTL Option )/0 to 1.5 V ( BCD Option)			
Indicator rating		1 Watt/30 Volts/100 mA				
Switching time	ms	15 ms				
Life (Min)		2 million cycles				
Connectors		SMA - N				
Actuator terminals		Solder pins or male 25 pin D-Sub connector				
Operating temperature range		-40°C to +85°C				
Storage temperature range		-55°C to +85°C				
Vibration (MIL STD 202, method 204D, cond.D)		10 - 2,000 Hz - 20 g operating				
Shock (MIL STD 202, method 213B, cond.C)		100 g/6 ms - ½ sine operating				

Reset: supply voltage time 1 sec. max./duty cycle 10%

RF PERFORMANCE

CONNECTORS	FREQUENCY RANGE GHz	V.S.W.R. (MAX)	INSERTION LOSS (MAX) dB	ISOLATION (MIN) dB	IMPEDANCE Ω	THIRD ORDER INTERMODULATION	
N	DC - 12.4	DC - 1	1.15	0.15	85	50	-160 dBc at +43 dBm (2 carriers 20 W)
		1 - 2	1.20	0.20	80		
		2 - 3	1.25	0.25	75		
		3 - 8	1.35	0.35	70		
		8 - 12.4	1.50	0.50	60		
SMA	DC - 18	DC - 3	1.10	0.15	80		
		3 - 8	1.20	0.20	75		
		8 - 12.4	1.20	0.25	65		
		12.4 - 18	1.40	0.35	60		

PASSIVE INTERMODULATION

<b>tone 1</b>	1,810 MHz, approximately 43 dBm
<b>tone 2</b>	1,850 MHz, approximately 43 dBm
<b>3RD ORDER PIM</b>	160 dBc at 1,770 MHz

Depending on application, carrier powers and frequencies — PIM measurements can vary. PIM testing is not measured during product acceptance test.

OUTSTANDING PIM PERFORMANCE

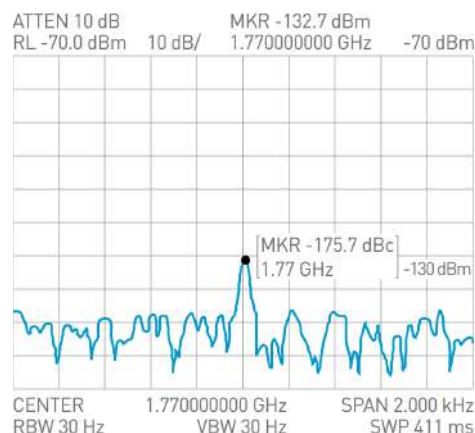

**TYPICAL RF PERFORMANCE**

*Example: SPDT N up to 12.4 GHz*

**INSERTION LOSS & ISOLATION**

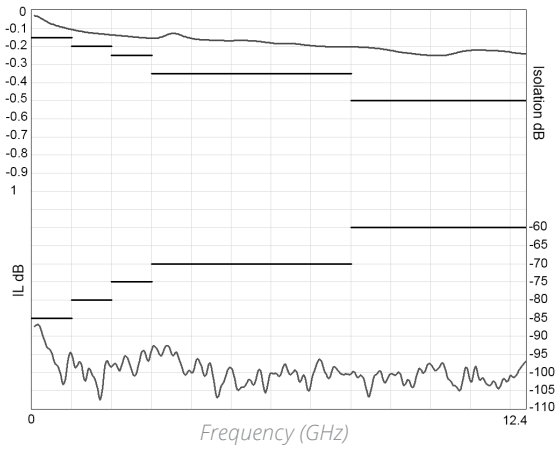

**V.S.W.R**

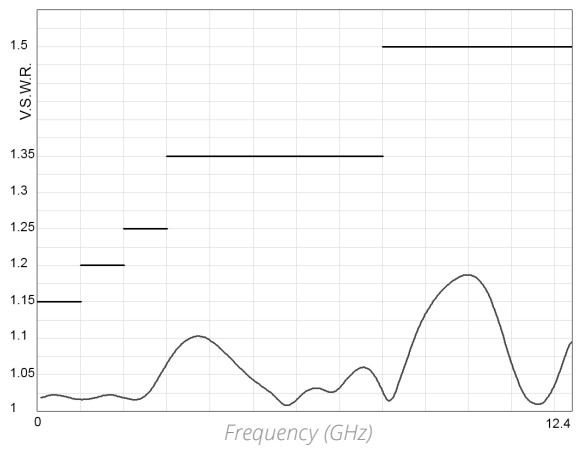

*Example: SPDT SMA up to 18 GHz*

**INSERTION LOSS & ISOLATION**

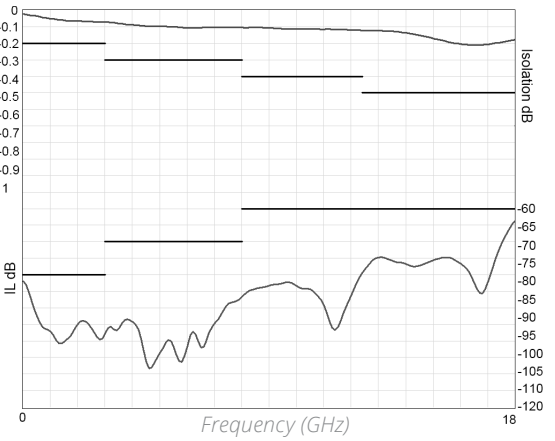

**V.S.W.R**

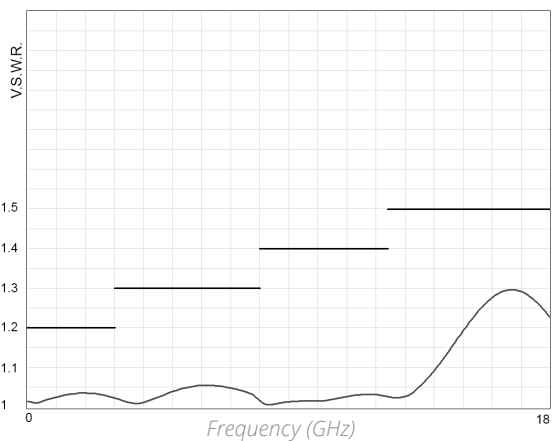

**Notes**

See electrical schematics from page 2-20 to 2-23.

RAMSES Series

TYPICAL OUTLINE DRAWING

EXAMPLE: SPDT N UP TO 12.4 GHz WITH PINS

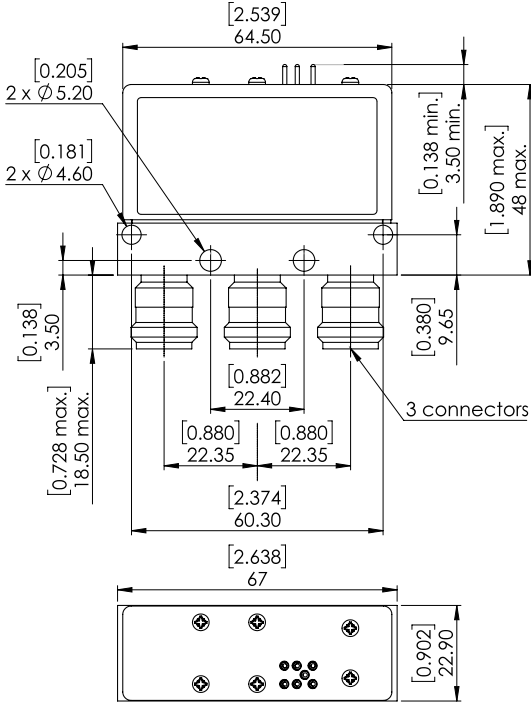

EXAMPLE: SPDT N UP TO 12.4 GHz WITH D-SUB

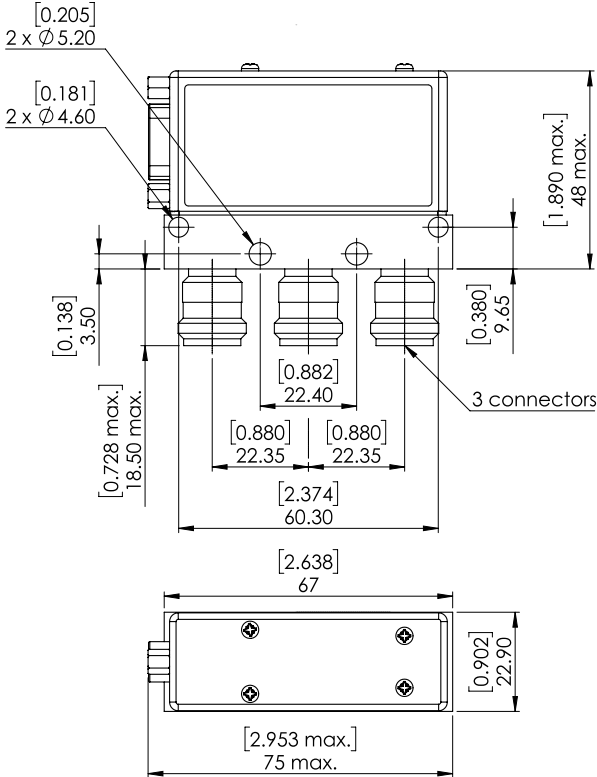

EXAMPLE: SPDT SMA UP TO 18 GHz

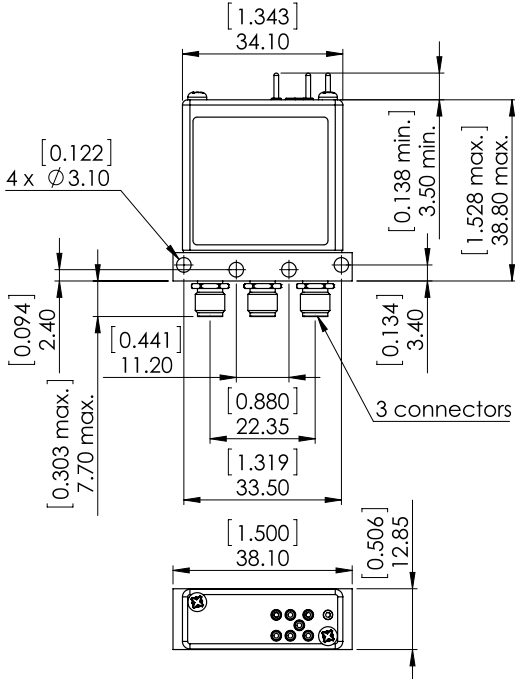

Notes

All dimensions are in millimeters [inches].

### DPDT LOW PIM UP TO 18 GHz



To meet growing market demands created by the deployment of 4G/LTE networks, Radiall has introduced a new range of Low PIM switches. RAMSES DPDT Low PIM switches are perfectly suited for RF test systems and test benches requiring excellent passive intermodulation performance up to 18 GHz; with a guarantee PIM performance of -160 dBc at +43 dBm over a life span of 2 million switching cycles. These products are specific to instrumentation and telecommunication applications.

*Example of P/N: R577163105LP is a DPDT Low PIM N 12.4 GHz latching with Indicators, Self Cut-Off, 28 Vdc, TTL driver, D-Sub connector.*

#### PART NUMBER SELECTION

SERIES PREFIX \_\_\_\_\_

FREQUENCY RANGE \_\_\_\_\_

- 1: N up to 12.4 GHz
- 4: SMA up to 18 GHz

TYPE \_\_\_\_\_

- 1: Failsafe
- 2: Failsafe + I.C.
- 3: Latching
- 4: Latching + I.C.
- 5: Latching + S.C.O. <sup>[1]</sup>
- 6: Latching + S.C.O. + I.C. <sup>[1]</sup>

ACTUATOR VOLTAGE \_\_\_\_\_

- 2: 12 Vdc
- 3: 28 Vdc

TTL OPTION \_\_\_\_\_

- 0: Without TTL driver
- 1: With TTL driver <sup>[1 & 3]</sup>

OPTIONS \_\_\_\_\_

- 0: Without option
- 1: Positive common <sup>[2]</sup>
- 3: With suppression diodes
- 4: With suppression diodes and positive common <sup>[2]</sup>

ACTUATOR TERMINALS \_\_\_\_\_

- 0: Solder pins
- 5: D-Sub connector <sup>[4]</sup>

R577

LP

#### Notes

1. I.C.: Indicator contact - S.C.O.: Self Cut-Off
1. Suppression diodes are already included in Self Cut-Off & TTL option
2. Positive common shall be specified only with type 3, 4, 5 & 6 because failsafe models can be used with both polarities
3. Polarity is not relevant to application for switches with TTL driver

RAMSES Series

GENERAL SPECIFICATIONS

OPERATING MODE		NORMALLY OPEN		LATCHING	
Nominal operating voltage (across operating temperature)	Vdc	12 (10.2 to 13)	28 (24 to 30)	12 (10.2 to 13)	28 (24 to 30)
Coil resistance (+/-10%)	Ω	35	200	38	225
Nominal operating current at 23 °C	mA	340	140	320	125
Average power		See Power Rating Chart on page 1-13			
TTL input	High level	2.2 to 5.5 V		800 μA max 5.5 V	
	Low level	0 to 0.8 V		20 μA max 0.8 V	
Indicator rating		1 W/30 V/100 mA			
Switching time (max)	ms	15			
Life (min)		2 million cycles			
Connectors		SMA - N			
Actuator terminals		Solder pins or male 9 pin D-Sub connector			
Operating temperature range		-40°C to +85°C			
Storage temperature range		-55°C to +85°C			
Vibration (MIL STD 202, method 204D, cond.C)		10-2000 Hz, 10 g		operating	
Shock (MIL STD 202, method 213B, cond.G)		50 g/11 ms, ½ sine		operating	

RF PERFORMANCE

CONNECTORS	FREQUENCY RANGE GHz	V.S.W.R. (MAX)	INSERTION LOSS (MAX) dB	ISOLATION (MIN) dB	IMPEDANCE Ω	THIRD ORDER INTERMODULATION
N	DC - 3 DC - 12.4	DC - 1	1.15	0.15	85	50  -160 dBc at +43 dBm (2 carriers 20 W)
		1 - 2	1.20	0.20	80	
		2 - 3	1.25	0.25	75	
		3 - 8	1.35	0.35	70	
		8 - 12.4	1.50	0.50	60	
SMA	DC - 3 DC - 18	DC - 3	1.20	0.20	80	
		3 - 8	1.30	0.30	70	
		8 - 12.4	1.40	0.40	65	
		12.4 - 18	1.50	0.50	60	

PASSIVE INTERMODULATION

TONE 1	1,810 MHz, approximately 43 dBm
TONE 2	1,850 MHz, approximately 43 dBm
3RD ORDER PIM	160 dBc at 1,770 MHz

Depending on application, carrier powers and frequencies — PIM measurements can vary. PIM testing is not measured during product acceptance test.

OUTSTANDING PIM PERFORMANCE

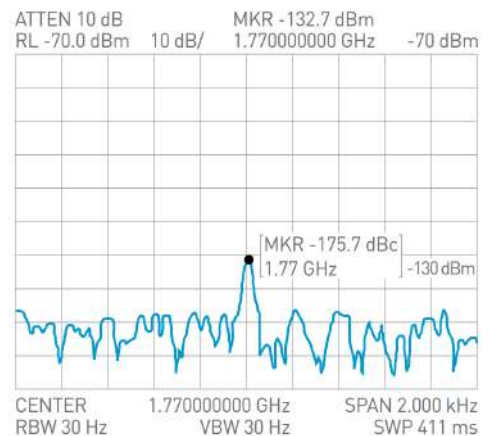

**TYPICAL RF PERFORMANCE**

*Example: DPDT N up to 12.4 GHz*

**INSERTION LOSS & ISOLATION**

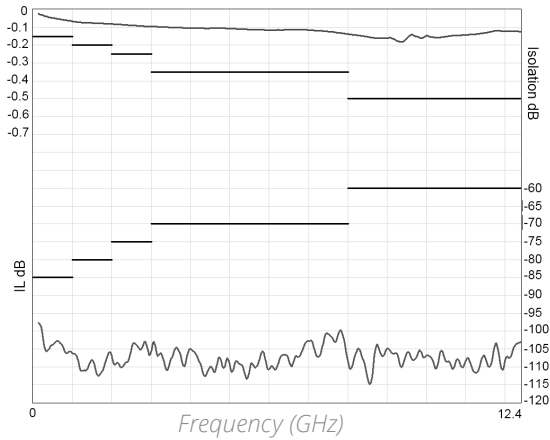

**V.S.W.R**

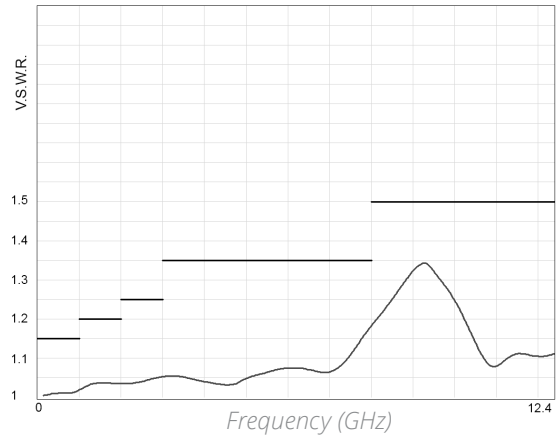

*Example: DPDT SMA up to 18 GHz*

**INSERTION LOSS & ISOLATION**

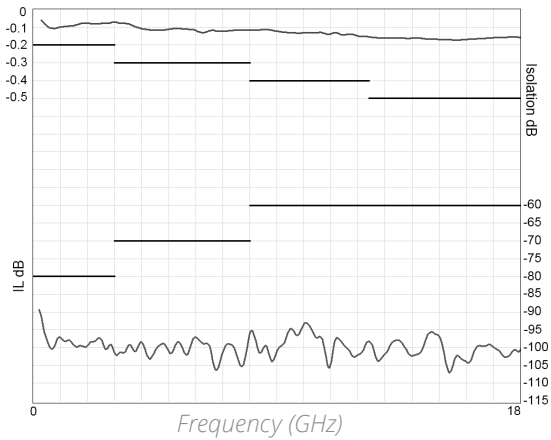

**V.S.W.R**

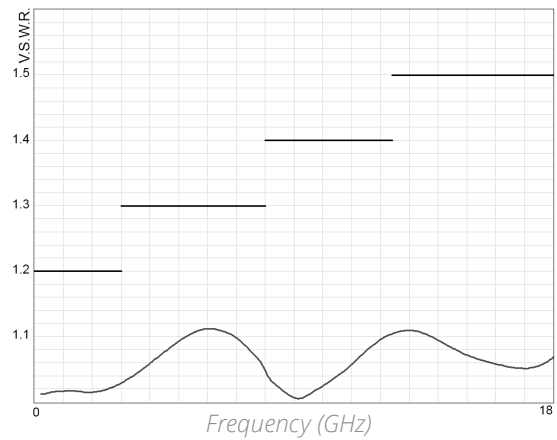

**Notes**

See electrical schematics from page 4-10 to 4-13.



TYPICAL OUTLINE DRAWING

EXAMPLE: DPDT N UP TO 12.4 GHz WITH PINS

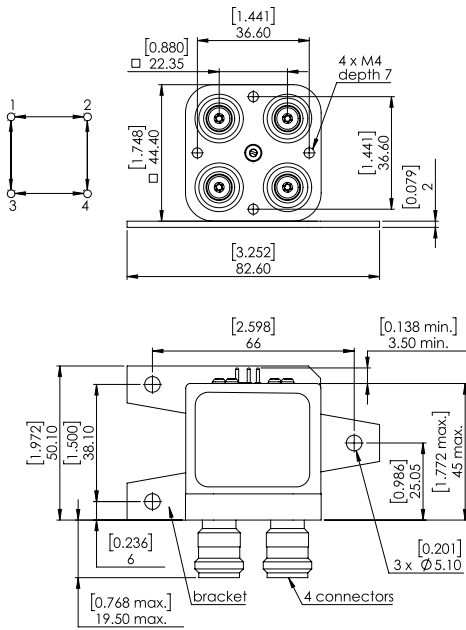

EXAMPLE: DPDT N UP TO 12.4 GHz WITH D-SUB

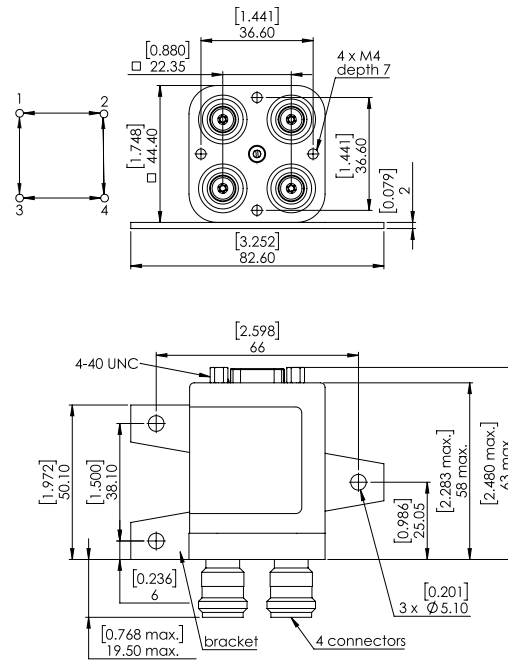

EXAMPLE: DPDT SMA UP TO 18GHz WITH PINS

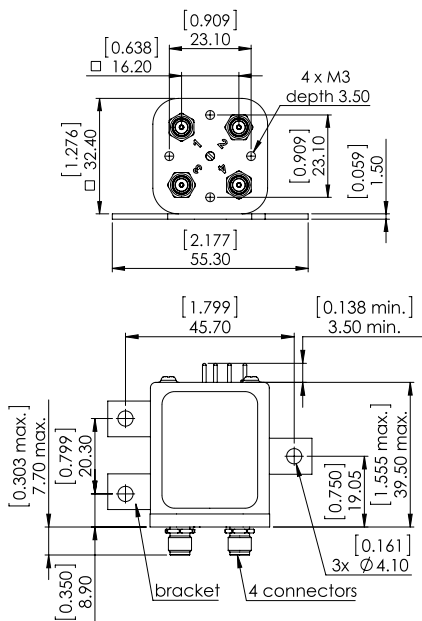

EXAMPLE: DPDT SMA UP TO 18 GHz WITH D-SUB

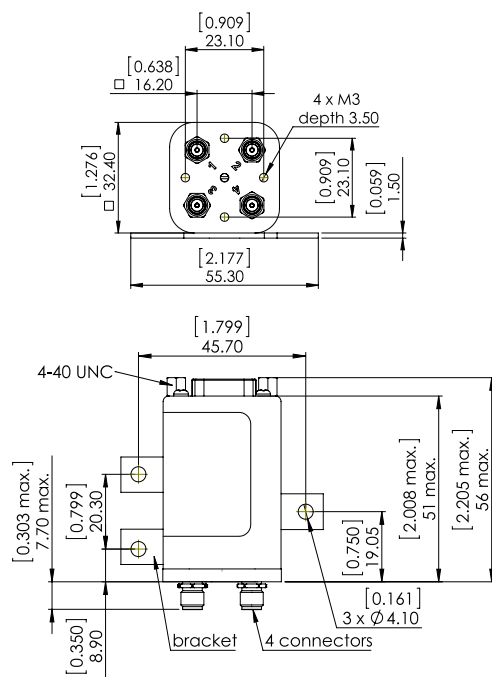

Notes

All dimensions are in millimeters [inches].

### SPNT LOW PIM UP TO 18 GHz



To meet growing market demands created by the deployment of 4G/LTE networks, Radiall has introduced a new range of Low PIM switches. RAMSES SPnT Low PIM switches are perfectly suited for RF test systems and test benches requiring excellent passive intermodulation performance up to 18 GHz; with a guarantee PIM performance of -160 dBc at +43 dBm over a life span of 2 million switching cycles. These products are specific to instrumentation and telecommunication applications.

*Example of P/N: R573403600LP is a SP6T Low PIM SMA up to 18 GHz, Normally Open, 28 Vdc, without option and solder pins.*

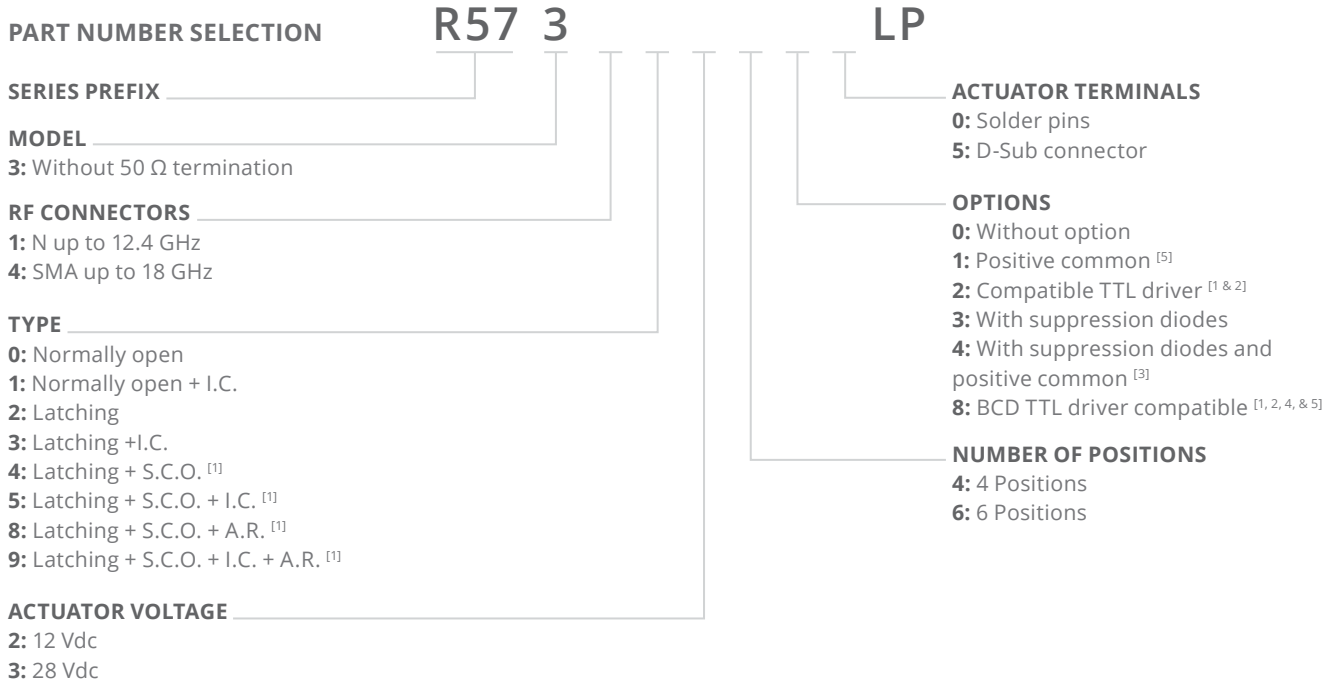

**Notes**

- I.C.: Contact / S.C.O.: Self Cut-Off / A.R.: Auto Reset
- 1. These models are already equipped with suppression diodes
- 2. Polarity is not relevant to application for switches with TTL driver
- 3. Option available only for type 0, 1, 2 and 3
- 4. Latching BCD driver enables also a global reset through driver code 0000 (see BCD logic coding page 1-11)
- 5. Option available only with type 0, 1, 2, 3 and with type 8 and 9 combined with 28 Vdc.

**GENERAL SPECIFICATIONS**

**Type 2, 3, 4 and 5:**

Latching models have a RESET pin which commands the reset of all positions. This command should be used before switching from one position to another. If not, two positions will be set at the same time.

*Note: During the RESET operation the global current is the nominal operating current multiplied by the number of positions.*

**Type 8, 9:**

Latching models with AUTOMATIC RESET are available; these products have an internal SET/RESET circuit which automatically resets all the non-selected positions and sets the desired position. This option simplifies the use of latching switches by suppressing the RESET command in switching sequence. An electronic circuit supplies successively groups of 2, 3 or 4 actuators, in order to limit the maximum current. The current with this option is the total current of 2, 3 or 4 reset coils in the same time (see table below).

*Example: During the AUTOMATIC RESET operation, at 28 Vdc, 4 position switch has a temporary consumption of only 250 mA, during 40 ms maximum.*

**SWITCHING SEQUENCE**

**FOR SP4T**

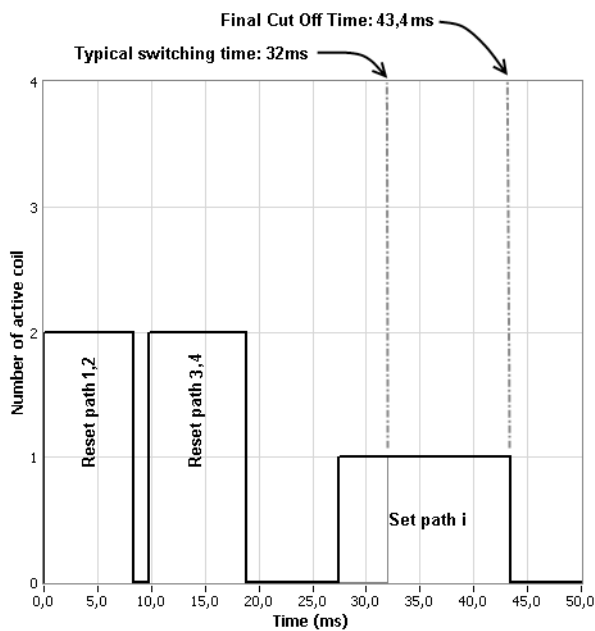

**FOR SP6T**

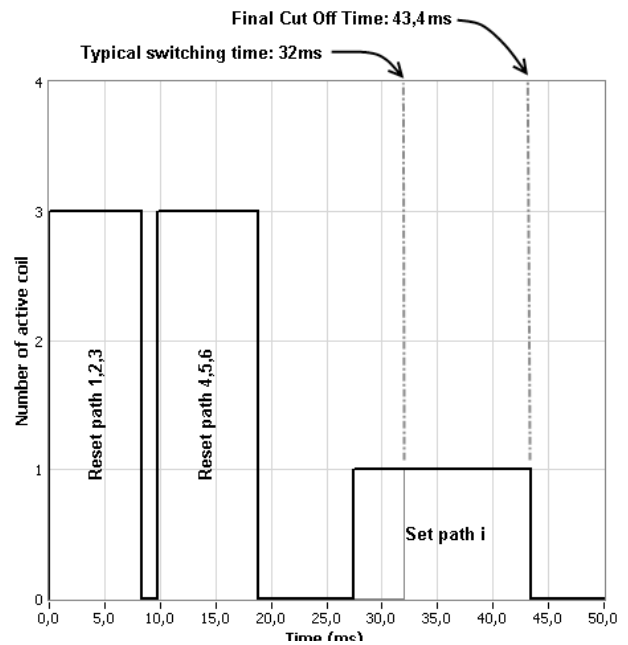

**Notes**

See electrical schematics from page 5-38 to 5-43.

RAMSES Series

GENERAL SPECIFICATIONS

OPERATING MODE		NORMALLY OPEN		LATCHING	
Nominal operating voltage (across operating temperature)	Vdc	12 (10.2 to 13)	28 (24 to 30)	12 (10.2 to 13)	28 (24 to 30)
Coil resistance at 23 °C (+/-10%)	Ω	47.5	275	38	225
Nominal operating current at 23 °C	mA	250	102	320 Reset SP4T: 1280 mA* Reset SP6T: 1920 mA*	125 Reset SP4T: 500 mA* Reset SP6T: 750 mA*
Average power		See Power Rating Chart on page 1-13			
TTL input	High level	2.2 to 5.5 V (TTL Option) / 3.5 to 5.5 V (BCD Option)			
	Low level	0 to 0.8 V (TTL Option) / 0 to 1.5 V (BCD Option)			
Indicator rating		1 W/30 V/100 mA			
Switching time (max)	ms	15 For automatic reset models: 40			
Life (min)		2 million cycles			
Connectors		SMA - N			
Actuator terminals		Solder pins or male 25 pin D-Sub connector			
Operating temperature range		-25 °C to +70 °C			
Storage temperature range		-55 °C to +85 °C			
Vibration (MIL STD 202, method 204D, cond.D)		10 - 2,000 Hz , 20 g		operating	
Shock (MIL STD 202, method 213B, cond.C)		100 g/6 ms, ½ sine		operating	

\*Reset: supply voltage time 1 sec. max./duty cycle 10%

RF PERFORMANCE

CONNECTORS	NUMBER OF POSITIONS	FREQUENCY RANGE GHz	V.S.W.R. (MAX)	INSERTION LOSS (MAX) dB	ISOLATION (MIN) dB	IMPEDANCE Ω	THIRD ORDER INTERMODULATION
SMA	4 and 6	DC - 18	DC - 3	1.20	0.20	80	-160 dBc at +43 dBm (2 carriers 20 W)
			3 - 8	1.30	0.30	70	
			8 - 12.4	1.40	0.40	60	
			12.4 - 18	1.50	0.50	60	
N		DC - 12.4	DC - 3	1.20	0.20	80	
			3 - 8	1.35	0.35	70	
			8 - 12.4	1.50	0.50	60	

PASSIVE INTERMODULATION

TONE 1	1,810 MHz, approximately 43 dBm
TONE 2	1,850 MHz, approximately 43 dBm
3RD ORDER PIM	160 dBc at 1,770 MHz

Depending on application, carrier powers and frequencies — PIM measurements can vary. PIM testing is not measured during product acceptance test.

OUTSTANDING PIM PERFORMANCE

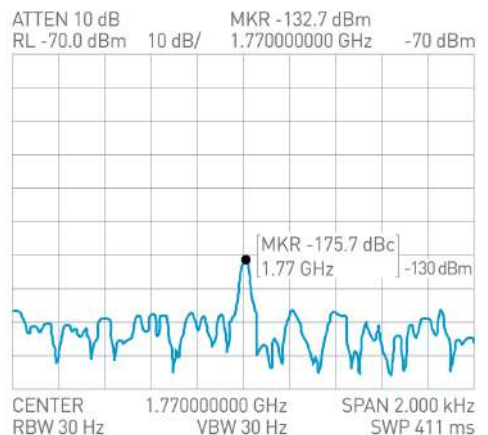

RAMSES Series

**TYPICAL RF PERFORMANCE**

*Example: SP6T N up to 12.4 GHz*

**INSERTION LOSS & ISOLATION**

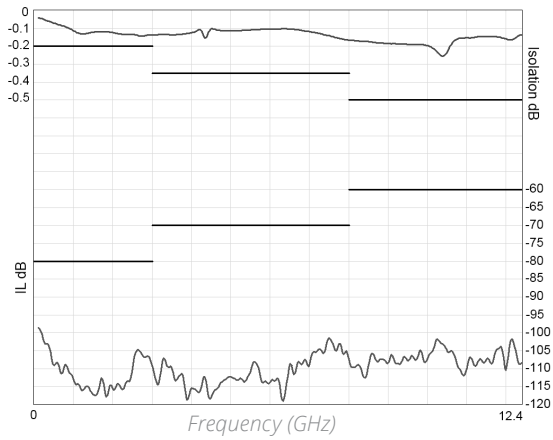

**V.S.W.R.**

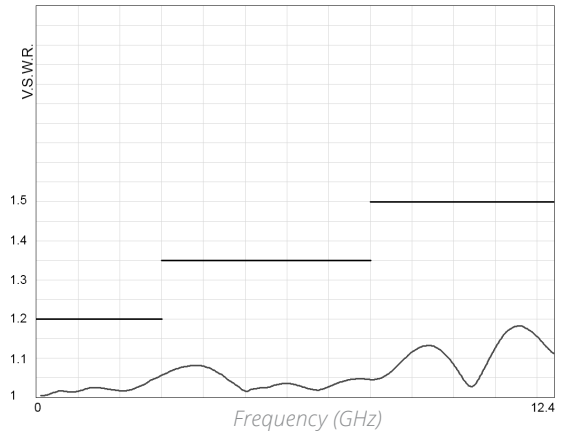

*Example: SP6T SMA up to 18 GHz*

**INSERTION LOSS & ISOLATION**

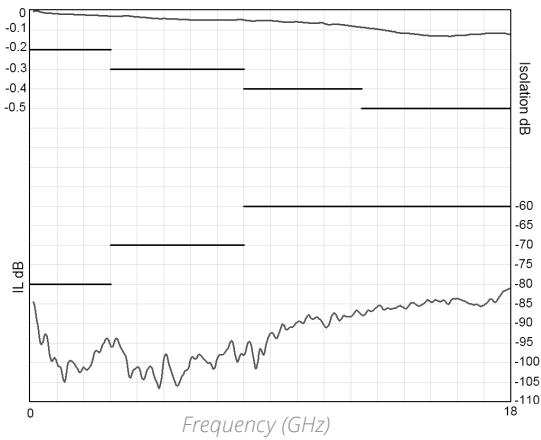

**V.S.W.R.**

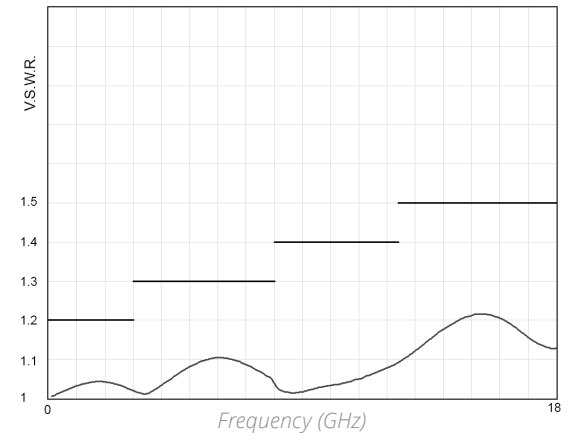

TYPICAL OUTLINE DRAWING

Example: SPnT SMA up to 18 GHz

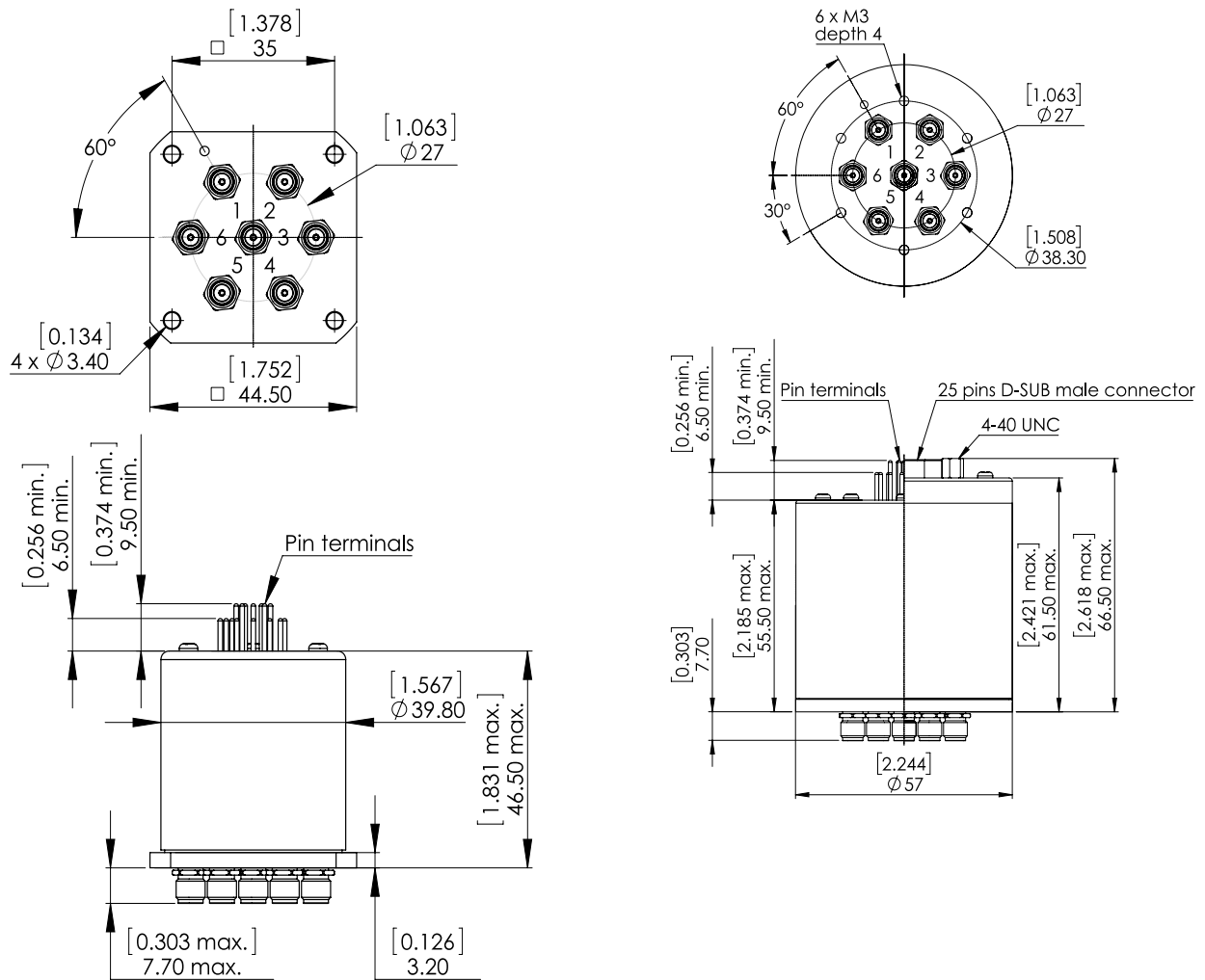

<b>SOLDER PINS</b>	Type 0 or 1 with option 0 - 1 - 3 or 4
	Type 2 or 3 with option 0 or 1

<b>SOLDER PINS</b>	Type 0 or 1 with option 2 or 8
	Type 2 or 3 with option 2 - 3 - 4 or 8
	Type 4 - 5 - 8 or 9 with option 0 - 2 or 8

<b>D-SUB CONNECTOR</b>	All models
------------------------	------------

Notes

All dimensions are in millimeters [inches].

RAMSES Series

Example: SPnT N up to 12.4 GHz

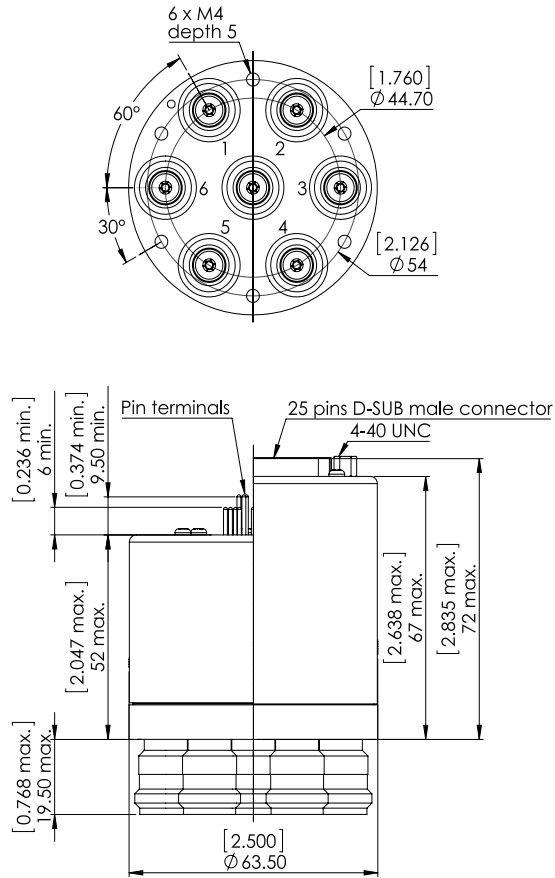

RF CONNECTOR ALLOCATION

SP4T

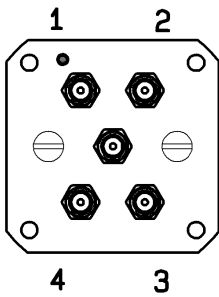

SMA

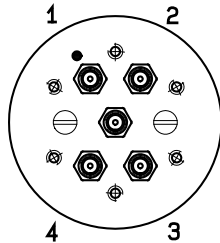

SP6T

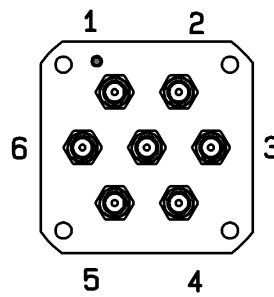

SMA

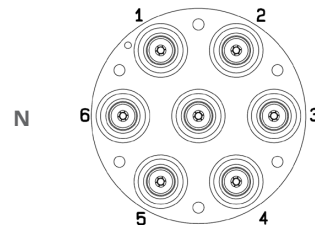
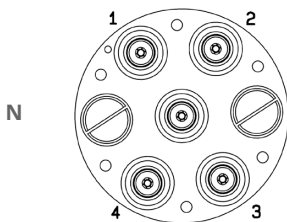
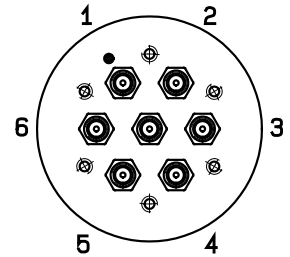

Notes

All dimensions are in millimeters [inches].

### COAXIAL LOW PIM SWITCHES - ELECTRICAL SCHEMATICS

TYPE		FAILSAFE	LATCHING		
Options		Without option	Without option	Cut-off	C+ and suppression diodes
		Indicator contact	Indicator contact	Cut-off and I.C.	C+, suppression diodes and I.C.
		Suppression diodes	Suppression diodes	Cut-off and TTL Driver	C+ and cut-off
		Suppression diodes and I.C.	Suppression diodes and I.C.	Cut-off, TTL and I.C.	C+, cut-off and I.C.
		TTL Driver	TTL Driver	C+	-
		TTL Driver and I.C.	TTL Driver and I.C.	C+ and I.C.	
Page Number	SPDT	see page 2-20	see page 2-21	see page 2-22	see page 2-23
	DPDT	see page 4-10	see page 4-11	see page 4-12	see page 4-13

TYPE		NORMALLY OPEN		LATCHING			
Options		Without option	BCD TTL driver	Without option	Cut-off	TTL Driver, Cut-off and Auto reset	C+ and suppression diodes
		Indicator contact	BCD TTL driver and I.C.	Indicator contact	Cut-off and I.C.	TTL Driver, Cut-off, Auto reset and I.C.	C+, suppression diodes and I.C.
		Suppression diodes	C+	Suppression diodes	Cut-off and Auto reset	BCD TTL Driver, Cut-off and Auto reset	C+, Cut-off and Auto reset
		Suppression diodes and I.C.	C+ and I.C.	Suppression diodes and I.C.	Cut-off, Auto reset and I.C.	BCD TTL Driver, Cut-off, Auto reset and I.C.	C+, Cut-off, Auto reset and I.C.
		TTL Driver	C+ and suppression diodes	TTL Driver	Cut-off and TTL Driver	C+	-
		TTL Driver and I.C.	C+, suppression diodes and I.C.	TTL Driver and I.C.	Cut-off, TTL and I.C.	C+ and I.C.	-
Page Number	SPnT	see page 5-38	see page 5-39	see page 5-40	see page 5-41	see page 5-42	see page 5-43





# SPACE

---



---

 Section 7 Table of Contents
**INTRODUCTION**

General Information .....	7-2
Radiall Specifications .....	7-3

**FLIGHT MODELS**

Low Power Coaxial SPDT Switch .....	7-4 to 7-15
Low Power Coaxial DPDT Switch.....	7-6 to 7-7
Low Power Coaxial T-Switch .....	7-8 to 7-9
Low Power Coaxial DP3T Switch .....	7-10 to 7-11
High Power Coaxial SPDT Switch .....	7-12 to 7-13
High Power Coaxial DP3T Switch .....	7-14 to 7-15
High Power Coaxial T-Switch .....	7-16 to 7-17

**THERMAL VACUUM SWITCHES FOR GROUND SEGMENTS**

General Information .....	7-18 to 7-20
---------------------------	--------------

Introduction

**GENERAL INFORMATION**



Radiall Hi-Rel switches are manufactured based on over 40 years of experience and thousands of products that have been designed, qualified, and delivered for both commercial and military applications. With a space heritage of over 25 years and products in flight on over 300 satellites around the world, Radiall guarantees the highest level of manufacturing, quality and reliability.

Radiall Hi-Rel coaxial switches have been fully evaluated and approved by the European Space Agency for Space use according to the generic specification ESCC3603. Radiall offers products tested at several levels based on the same hardware including:

- EM: Engineering Model
- QM: Qualification Model
- PFM: Proto Flight Model

Radiall also provides a full range of low cost Hi-Rel switches for space applications. These products meet the requirements for communication satellite applications according to RAD-GEN-SWIT-001 and follow detailed specifications according to the Radiall part number list (see page 7-3).

**ENVIRONMENTAL CHARACTERISTICS**

		QUALIFICATION LEVEL
Operation temperature range		- 30°C/+ 85°C
Non operation temperature range		- 40°C/+ 85°C
Vibration	Sinus	5 – 100 Hz/20 g
	Random	20 – 2,000 Hz/28.57 g
Shocks	-	½ sinus / 1200 g / 0.25 ms
Pressure	-	Free space vacuum

## Introduction

## RADIALL SPECIFICATIONS

## RADIALL BEST RUNNERS PART LIST (FM P/N)

DETAIL SPECIFICATION	PRODUCT	POWER CAP.	CONNECTORS	RADIALL P/N FM	DESIGNATION
RAD - DET - SPDT - 001	SPDT	Low power	SMA	R571 492 601	Fixing plate with pins
				R571 472 601	Lay down with pins
				R571 471 601	Lay down with D-sub
			SMA 2.9	R571 892 601	Fixing plate with pins
				R571 872 601	Lay down with pins
				R571 871 601	Lay down with D-sub
RAD - DET - SPDT - 002	SPDT	High power	TNC	R565 271 601	Lay down with D-sub, High Cavity
				R565 371 601	Lay down with D-sub, Standard Cavity
RAD - DET - DPDT - 006	DPDT	Low power	SMA	R578 483 601	Stand up with D-sub
				R578 472 601	Lay down with pins
				R578 482 601	Stand up with pins
			SMA 2.9	R578 872 601	Lay down with pins
				R578 883 601	Stand up with D-sub
				R578 882 601	Stand up with pins
RAD - DET - TSSD - 002	T-Switch Sequentiel	Low power	SMA	R587 432 601	Lay down with pins
				R587 443 601	Stand up with D-sub
				R587 442 601	Stand up with pins
			SMA 2.9	R587 832 621	Lay down with pins
				R587 842 621	Stand up with pins
				R587 843 621	Stand up with D-sub
RAD - DET - TRSD - 002	T-Switch	High power	TNC	R588 371 601	Lay down with D-sub
				R588 381 611	Stand up with D-sub
RAD - DET - TRSD - 003	T-Switch Random	Low power	SMA	R587 492 601	Fixing plate with pins
				R587 472 601	Lay down with pins
				R587 482 601	Stand up with pins
			SMA 2.9	R587 872 601	Lay down with pins
				R587 882 601	Stand up with pins
				R587 883 601	Stand up with D-sub
RAD - DET - DP3T - 001	DP3T	Low power	SMA	R586 471 601	Lay down with D-sub
			SMA 2.9	R586 871 601	Lay down with D-sub
RAD - DET - DP3T - 002	DP3T	High power	TNC	R564 271 601	Lay down with D-sub, High Cavity
				R564 371 601	Lay down with D-sub, Standard Cavity
				R564 372 601	Lay down with pins, Standard Cavity

## LOW POWER COAXIAL SPDT SWITCH



Low power latching Coaxial SPDT Switch according to Radiall specification RAD-DET-SPDT-001:

- DC to 22 GHz with SMA connectors
- Up to 31 GHz with SMA 2.9 connectors
- Telemetry circuit
- Suppression diodes
- D-Sub or solder pins
- Lay down or Fixing plate
- 44 grams and up

### GENERAL SPECIFICATIONS

	UNIT	MIN	TYPICAL	MAX
<b>Actuation Voltage</b>	V	+22	+26	+29
<b>Pick-Up Voltage</b>	V	-	-	+20.5
<b>Actuation Current</b>	mA	-	-	-
at +29 V, +25 °C		-	129	139
at +29 V, -30 °C		-	164	176
at +29 V, +85 °C		-	105	113
<b>Switching Time</b>	ms	-	-	20
<b>Pulse Duration</b>	ms	20	-	1,000
<b>Coil Resistance (at +25 °C)</b>	Ω	210	225	-
<b>RF Contact Resistance</b>	mΩ	-	-	100
<b>TLM Indicator Circuit</b>	-	-	-	-
<b>Contact Closed</b>	mΩ	-	-	1,000
<b>Contact Open</b>	MΩ	10	10	-
<b>Contact Current</b>	mA	-	-	100
<b>Coil Isolation at 500 VDC</b>	MΩ	10	-	-
<b>Dielectric Withstanding at 50 or 60 Hz</b>	Vrms	500	-	-
<b>Mass</b>	g	-	-	-
Variant 001-004: SPDT, Fixing Plate, Pins		-	-	44
Variant 002-005: SPDT, Lay down, Pins		-	-	62
Variant 003-006: SPDT, Lay down, D-Sub		-	-	72
<b>Torque Screws for:</b>	N.m	-	-	-
Fixing unit		-	-	2.0
DC connector		0.8	1.1	0.44
SMA connector		-	-	1.15

### RF PERFORMANCE

DC to 22 GHz SMA

FREQUENCY	GHZ	DC - 4.2	4.2 - 10.7	10.7 - 12.75	12.75 - 14.5	14.5 - 22
<b>Insertion Loss (max)</b>	dB	0.12	0.20	0.25	0.30	0.35
<b>VSWR (max)</b>		1.20	1.20	1.20	1.25	1.33
Return Loss (min)	(dB)	(21)	(21)	(21)	(19)	(17)
<b>Isolation (min)</b>	dB	70			65	
<b>E-Field Shielding Effectiveness (min)</b>	dB <sub>i</sub>	75	70			

Ka – band SMA 2.9

FREQUENCY	GHZ	17.5-21.5	21.5 - 27.5	27.5 - 31
<b>Insertion Loss (max)</b>	dB	0.45	0.45	0.50
<b>VSWR (max)</b>		1.33	1.35	1.40
Return Loss (min)	(dB)	(17.0)	(16.5)	(15.6)
<b>Isolation (min)</b>	dB	65	60	55
<b>E-Field Shielding Effectiveness (min)</b>	dB <sub>i</sub>	70	60	
<b>Power Handling (max)</b>	W	10	5	

Flight Models

**SCHEMATICS & DRAWINGS**

SDPT, LAY DOWN, PINS:

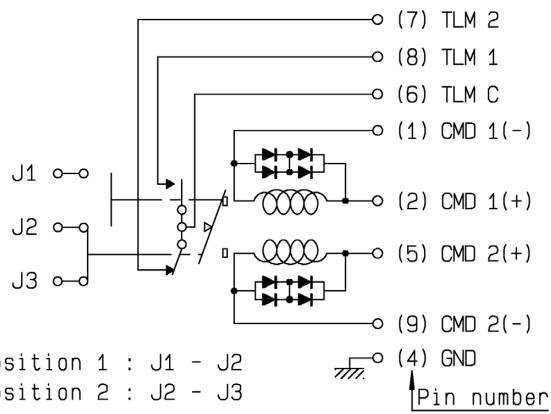

SPDT, fixing plate with pins



SPDT, lay down with D-sub



SPDT, lay down with pins

**POWER DERATING GRAPH**

VARIANT 001 TO 003: DC TO 22 GHz SMA

Power derating versus frequency

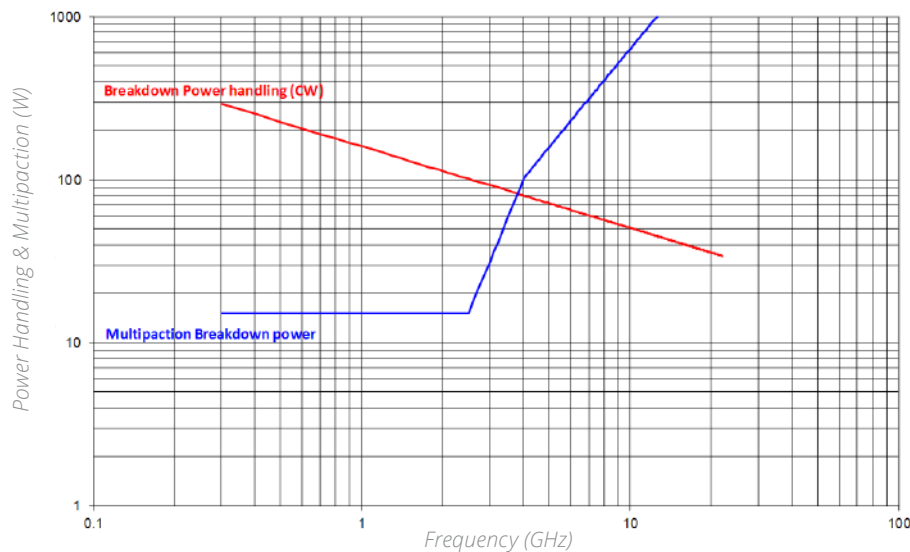

Frequency (GHz)	Breakdown Power Handling (W)	Breakdown Multipaction Power (W)
0.3	292.1	15.2
2.3	105.5	15.2
2.4	103.3	15.2
2.5	101.2	15.2
2.6	99.2	17.8
2.7	97.4	20.7
2.8	95.6	23.9
2.9	94.0	27.5
3.0	92.4	31.5
4.0	80.0	101.6
5.0	71.6	158.8
6.0	65.3	228.6
7.0	60.5	311.2
8.0	56.6	406.4
9.0	53.3	514.4
10.0	50.6	635.0
12.0	46.2	914.5
14.0	42.8	1244.7
16.0	40.0	1625.7
18.0	37.7	2057.5
20.0	35.8	2540.2
22.0	34.1	3073.6

## LOW POWER COAXIAL DPDT SWITCH



Low power latching Coaxial DPDT Switch according to Radiall specification RAD-DET-DPDT-006:

- DC to 22 GHz with SMA connectors
- Up to 31 GHz with SMA 2.9 connectors
- Telemetry circuit
- Suppression diodes
- D-Sub or solder pins
- Lay down or Stand up
- 57 grams and up

### GENERAL SPECIFICATIONS

	UNIT	MIN	TYPICAL	MAX
Actuation Voltage	V	+22	+26	+29
Pick-Up Voltage	V	-	-	+20.5
Actuation Current	mA	-	-	-
at +29 V, +25 °C		-	129	139
at +29 V, -30 °C		-	164	176
at +29 V, +85 °C		-	105	113
Switching Time	ms	-	-	25
Pulse Duration	ms	20	-	1,000
Coil Resistance (at +25 °C)	Ω	210	225	-
RF Contact Resistance	mΩ	-	-	100
TLM Indicator Circuit	-	-	-	-
Contact Closed	mΩ	-	-	1,000
Contact Open	MΩ	10	-	-
Contact Current	mA	-	-	100
Coil Isolation at 500 VDC	MΩ	10	-	-
Dielectric Withstanding at 50 or 60 Hz	Vrms	500	-	-
Mass	g	-	-	-
Variant 001-005: C-Switch, Stand up D-Sub		-	-	80
Variant 002-004: C-Switch, Lay down Pins		-	-	57
Variant 003-006: C-Switch, Stand up Pins		-	-	63

### RF PERFORMANCE

DC to 22 GHz SMA

FREQUENCY	GHZ	DC - 4.2	4.2 - 8.4	8.4 - 14.5	14.5 - 18	18 - 20	20 - 22
Insertion Loss (max)	dB	0.15	0.25	0.30	0.40	0.50	0.50
VSWR (max) Return Loss (min)	(dB)	1.20 (21)	1.25 (19)	1.25 (19)	1.33 (17)	1.33 (17)	1.40 (15.6)
Isolation (min)	dB	70				65	
E-Field Shielding Effectiveness (min)	dBi	75	70	68	65	60	

Ka – Band SMA 2.9

FREQUENCY	GHZ	17.5-21.5	27.5 - 31
Insertion Loss (max)	dB	0.50	0.65
VSWR (max) Return Loss (min)	(dB)	1.33 (17.7)	1.40 (15.6)
Isolation (min)	dB	65	60
E-Field Shielding Effectiveness (min)	dBi	60	60
Power Handling (max)	W	10	5



**SCHEMATICS & DRAWINGS**

C-SWITCH, SMA, LAY DOWN PINS:

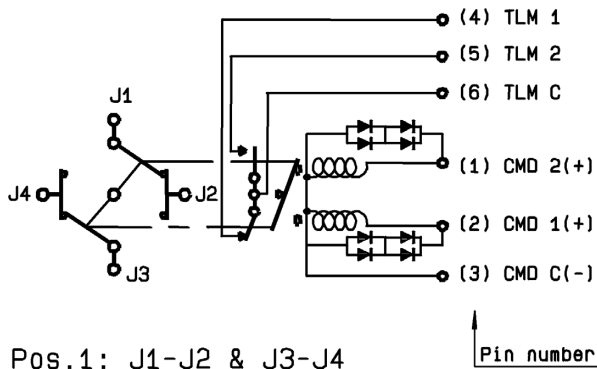

Pos.1: J1-J2 & J3-J4  
 Pos.2: J1-J4 & J2-J3

↑  
 Pin number



C-Switch, stand up with pins



C-Switch, lay down with pins



C-Switch, stand up with D-sub

**POWER DERATING GRAPH**

VARIANT 001 TO 003: DC TO 22 GHz SMA

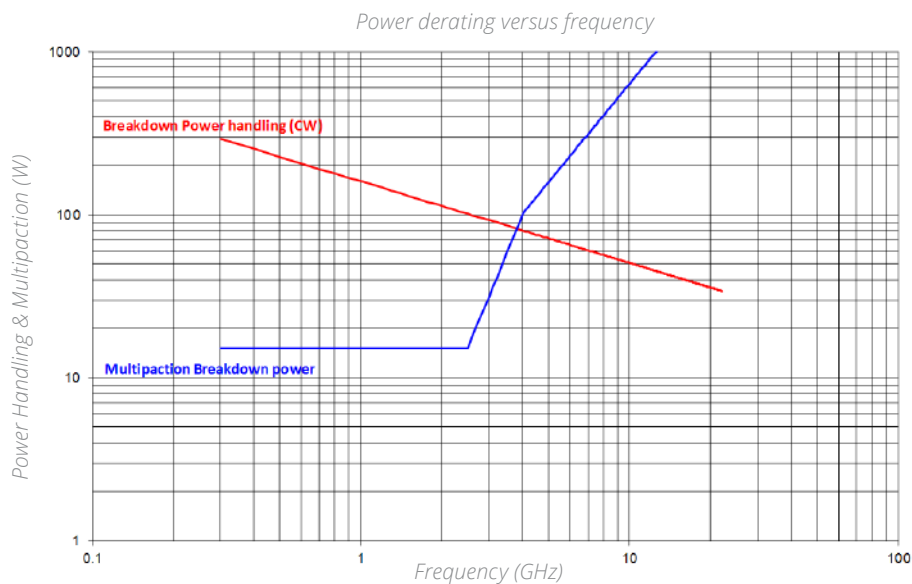

Frequency (GHz)	Breakdown Power Handling (W)	Breakdown Multipaction Power (W)
0.3	292.1	15.2
2.3	105.5	15.2
2.4	103.3	15.2
2.5	101.2	15.2
2.6	99.2	17.8
2.7	97.4	20.7
2.8	95.6	23.9
2.9	94.0	27.5
3.0	92.4	31.5
4.0	80.0	101.6
5.0	71.6	158.8
6.0	65.3	228.6
7.0	60.5	311.2
8.0	56.6	406.4
9.0	53.3	514.4
10.0	50.6	635.0
12.0	46.2	914.5
14.0	42.8	1244.7
16.0	40.0	1625.7
18.0	37.7	2057.5
20.0	35.8	2540.2
22.0	34.1	3073.6

Flight Models

### LOW POWER COAXIAL T-SWITCH



Low power latching Coaxial Switch according to Radial specification RAD-DET-TSSD-002 and RAD-DET-TSRD-003:

- Random or Sequential drive
- DC to 22 GHz with SMA connectors
- Up to 31 GHz with SMA 2.9 connectors
- Telemetry circuit
- Suppression diodes
- D-Sub or solder pins
- Stand up or Lay down or fixing plate
- 58 grams and up

#### GENERAL SPECIFICATIONS

	RAD - DET - TSSD - 002 Sequential Drive				RAD - DET - TSRD - 003 Random Drive		
	UNIT	MIN	TYPICAL	MAX	MIN	TYPICAL	MAX
<b>Actuation Voltage</b>	V	+22	+26	+29	+22	+26	+29
<b>Pick-Up Voltage</b>	V	-	-	+20.5	-	-	+20.5
<b>Actuation Current</b>	mA	-	-	-	-	-	-
at +29 V, +25 °C		-	345	364	-	285	305
at +29 V, -30 °C		-	439	462	-	365	390
at +29 V, +85 °C	-	280	295	-	234	250	
<b>Switching Time</b>	ms	-	-	25	-	-	20
<b>Pulse Duration</b>	ms	20	-	1,000	20	-	1,000
<b>Coil Resistance (at +25 °C)</b>	Ω	79.8	84	-	88	95	-
<b>RF Contact Resistance</b>	mΩ	-	-	100	-	-	100
<b>TLM Indicator Circuit</b>	-	-	-	-	-	-	-
Contact Closed	mΩ	-	-	1,000	-	-	1,000
Contact Open	MΩ	10	-	-	10	-	-
Contact Current	mA	-	-	100	-	-	100
<b>Coil Isolation at 500 VDC</b>	MΩ	10	-	-	10	-	-
<b>Dielectric Withstanding at 50 or 60 Hz</b>	Vrms	500	-	-	500	-	-
<b>Mass</b>	g	-	-	-	-	-	-
T-Switch, Lay down Pins		-	-	73	-	-	64
T-Switch, Stand up D-Sub		-	-	100	-	-	100
T-Switch, Stand up Pins		-	-	75	-	-	75
T-Switch, Fixing Plate		-	-	-	-	-	58
<b>Torque Screws for:</b>	N.m	-	-	-	-	-	-
Fixing unit		-	-	2.0	-	-	2.0
D-sub connector		0.27	-	0.44	-	-	N/A
RF connector		0.8	1.1	1.15	0.8	1.1	1.15

#### RF PERFORMANCE

DC to 22 GHz SMA

FREQUENCY	GHZ	DC-4.2	4.2-5.5	5.5-6.6	6.6-7.7	7.7-8.8	8.8-10.5	10.5-14.5	14.5-17.8	17.8-20	20-22
<b>Insertion Loss (max)</b>	dB	0.15	0.17	0.18	0.21	0.24	0.30	0.35	0.45	0.50	0.50
<b>VSWR (max)</b> Return Loss (min)	(dB)	1.20 (21)	1.22 (20)	1.25 (19)	1.25 (19)	1.25 (19)	1.25 (19)	1.25 (19)	1.33 (17)	1.33 (17)	1.40 (15.6)
<b>Isolation (min)</b>	dB	70						65			
<b>E-Field Shielding Effectiveness (min)</b>	dBi	75			70		65		65		

Ka – Band SMA 2.9

FREQUENCY	GHZ	17.5-21.5	27.5 - 31
<b>Insertion Loss (max)</b>	dB	0.50	0.65
<b>VSWR (max)</b> Return Loss (min)	(dB)	1.33 (17)	1.40 (15.6)
<b>Isolation (min)</b>	dB	65	60
<b>E-Field Shielding Effectiveness (min)</b>	dBi	60	60
<b>Power Handling (max)</b>	W	10	5

**SCHEMATICS & DRAWINGS**

**SEQUENTIAL DRIVE**

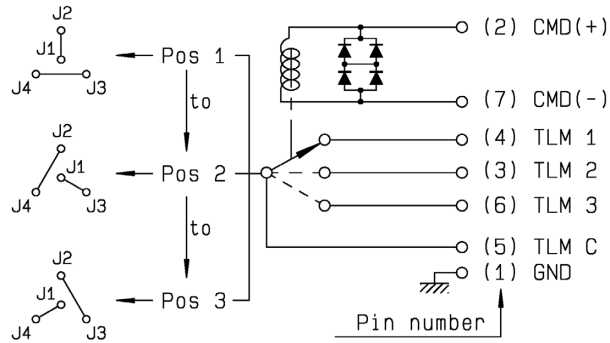

**RANDOM DRIVE**

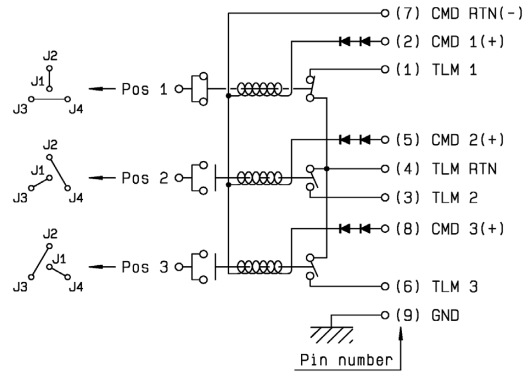

T-Switch, lay down with pins



T-Switch, stand up with D-Sub



T-Switch, fixing plate with pins

**POWER DERATING GRAPH**

VARIANT 001 TO 003: DC TO 22 GHz SMA

Power derating versus frequency

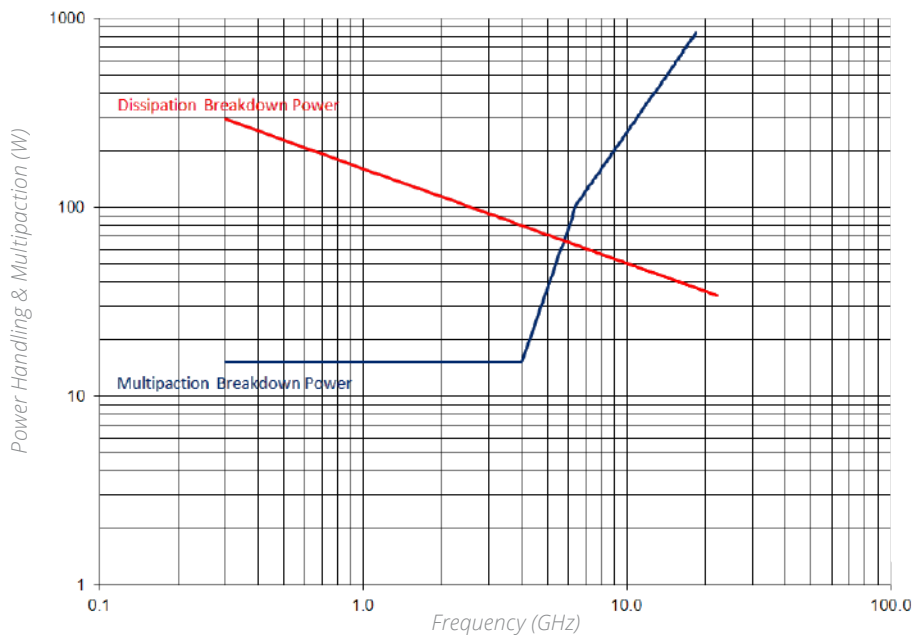

Frequency (GHz)	Dissipation Breakdown Power (W)	Multipaction Breakdown Power (W)
0.3	292.1	15.2
0.4	253.0	15.2
0.5	226.3	15.2
0.6	206.6	15.2
0.7	191.2	15.2
0.8	178.9	15.2
0.9	168.7	15.2
1.0	160.0	15.2
2.0	113.1	15.2
3.0	92.4	15.2
4.0	80.0	15.2
5.0	71.6	37.1
6.0	65.3	77.0
7.0	60.5	121.6
8.0	56.6	158.8
9.0	53.3	200.9
10.0	50.6	248.1
12.0	46.2	357.2
14.0	42.8	486.2
16.0	40.0	635.0
18.0	37.7	809.7
20.0	35.8	992.3
22.0	34.1	1200.6

## LOW POWER COAXIAL DP3T SWITCH

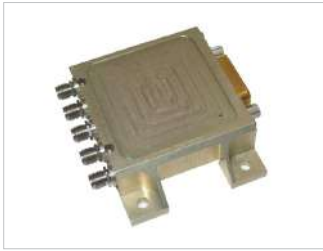

Low power latching Coaxial Switch according to Radiall specification

RAD-DET-DP3T-001:

- DC to 22 GHz with SMA connectors
- DC to 31 GHz with SMA 2.9 connectors
- Telemetry circuit
- Suppression diodes
- D-Sub
- Lay down
- 106 grams

### GENERAL SPECIFICATIONS

	UNIT	MIN	TYPICAL	MAX
<b>Actuation Voltage</b>	V	+22	+26	+29
<b>Pick-Up Voltage</b>	V	-	-	+20.5
<b>Actuation Current</b>	mA	-	-	-
at +29 V, +25 °C		-	129	139
at +29 V, -30 °C		-	164	176
at +29 V, +85 °C		-	105	113
<b>Switching Time</b>	ms	-	-	20
<b>Pulse Duration</b>	ms	20	-	1,000
<b>Coil Resistance (at +25 °C)</b>	Ω	210	225	-
<b>RF Contact Resistance</b>	mΩ	-	-	100
<b>TLM Indicator Circuit</b>	-	-	-	-
Contact Closed	mΩ	-	-	1,000
Contact Open	MΩ	10	-	-
Contact Current	mA	-	-	100
<b>Coil Isolation at 500 VDC</b>	MΩ	10	-	-
<b>Dielectric Withstanding at 50 or 60 Hz</b>	Vrms	500	-	-
<b>Mass</b>	g	-	-	106
<b>Torque Screws for:</b>	N.m	-	-	-
Fixing unit		-	-	2.0
D-sub connector		0.27	-	0.44
RF connector		0.8	1.1	1.15

### RF PERFORMANCE

DC to 22 GHz SMA

FREQUENCY	GHZ	DC - 4.2	4.2 - 10.7	10.7 - 12.75	12.75 - 14.5	14.5 - 22
Insertion Loss (max)	dB	0.12	0.20	0.25	0.30	0.35
VSWR (max)	(dB)	1.20	1.20	1.20	1.25	1.33
Return Loss (min)		(21)	(21)	(21)	(19)	(17)
Isolation (min)	dB	70			65	
E-Field Shielding Effectiveness (min)	dB	75	70			

Ka – Band SMA 2.9

FREQUENCY	GHZ	17.5-21.5	21.5 - 27.5	27.5 - 31
Insertion Loss (max)	dB	0.45	0.45	0.50
VSWR (max)	(dB)	1.33	1.35	1.40
Return Loss (min)		(17)	(16.5)	(15.6)
Isolation (min)	dB	65	60	
E-Field Shielding Effectiveness (min)	dB	70	60	
Power Handling (max)	W	10	5	

**SCHEMATICS & DRAWINGS**

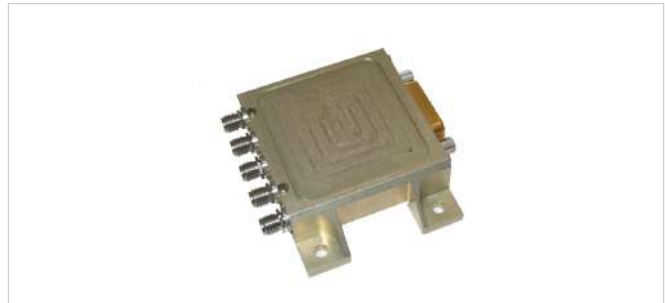
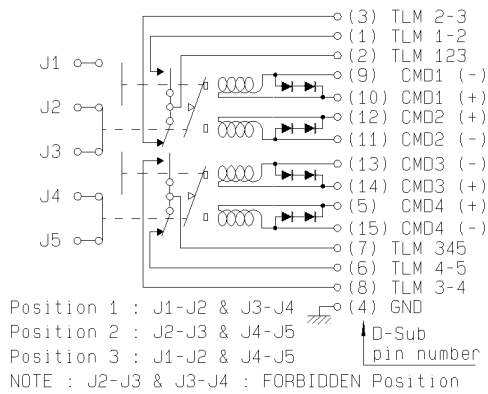

DP3T, lay down with D-sub

**POWER DERATING GRAPH**

VARIANT 001: DC TO 22 GHz SMA

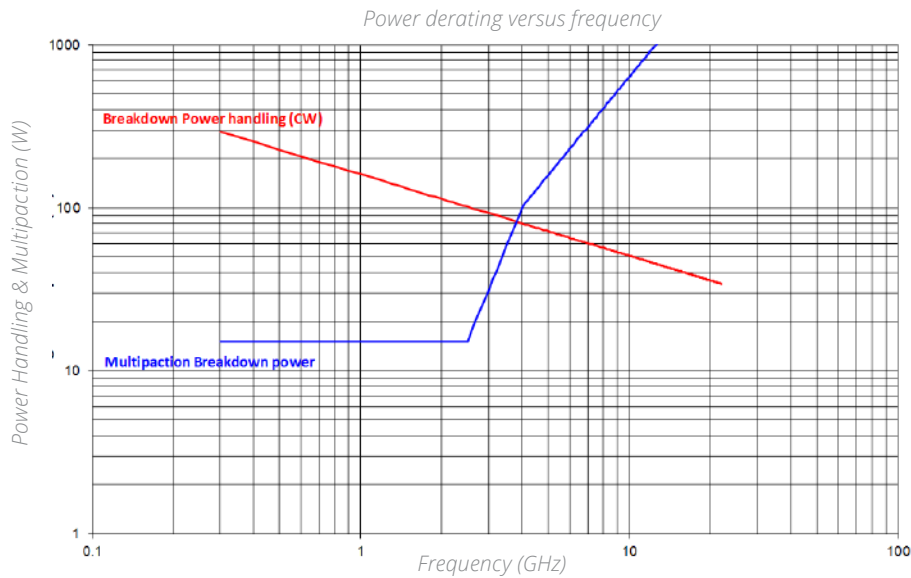

Frequency (GHz)	Breakdown Power Handling (W)	Breakdown Multipaction Power (W)
0.3	292.1	15.2
2.3	105.5	15.2
2.4	103.3	15.2
2.5	101.2	15.2
2.6	99.2	17.8
2.7	97.4	20.7
2.8	95.6	23.9
2.9	94.0	27.5
3.0	92.4	31.5
4.0	80.0	101.6
5.0	71.6	158.8
6.0	65.3	228.6
7.0	60.5	311.2
8.0	56.6	406.4
9.0	53.3	514.4
10.0	50.6	635.0
12.0	46.2	914.5
14.0	42.8	1244.7
16.0	40.0	1625.7
18.0	37.7	2057.5
20.0	35.8	2540.2
22.0	34.1	3073.6

## HIGH POWER COAXIAL SPDT SWITCH



High power latching Coaxial SPDT Switch according to Radiall specification RAD-DET-SPDT-002::

- TNC connectors
- Up to 2.2 GHz, with 160 Watts CW
- Up to 4.8 GHz, with 150 Watts CW
- Telemetry circuit
- Suppression diodes
- D-Sub
- Lay down
- 275 g

### GENERAL SPECIFICATIONS

	UNIT	MIN	TYPICAL	MAX
<b>Actuation Voltage</b>	V	+20	+26	+30
<b>Pick-Up Voltage</b>	V	-	-	+19
<b>Actuation Current</b>		-	-	-
<i>at +29 V, +25 °C</i>	mA	178	188	198
<i>at +29 V, -30 °C</i>		227	239	251
<i>at +29 V, +85 °C</i>		145	153	161
<b>Switching Time</b>	ms	-	25	35
<b>Pulse Duration</b>	ms	50	-	1,000
<b>Coil Resistance (at +25 °C)</b>	Ω	152	160	168
<b>RF Contact Resistance</b>	mΩ	-	-	100
<b>TLM Indicator Circuit</b>	-	-	-	-
<i>Contact Closed</i>	mΩ	-	-	1,000
<i>Contact Open</i>	MΩ	2	-	-
<i>Contact Current</i>	mA	-	-	100
<b>Coil Isolation at 500 VDC</b>	MΩ	1	-	-
<b>Dielectric Withstanding at 50 or 60 Hz</b>	Vrms	500	-	-
<b>Mass</b> <i>Variants 001 and 002</i>	g	-	-	275
<b>Torque Screws for:</b>		-	-	-
<i>Fixing unit</i>	N.m	-	-	2.0
<i>D-sub connector</i>		0.27	-	0.44
<i>RF connector</i>		1.7	-	2.65

### RF PERFORMANCE

FREQUENCY	GHZ	DC - 2.2 GHz Variant 001			DC - 4.8 GHz Variant 002			
		0.04 - 1.0	1.0 - 1.6	1.6 - 2.2	0.04 - 1.0	1.0 - 1.6	1.6 - 2.2	2.2 - 4.8
Insertion Loss (max)	dB	0.12			0.12			0.22
VSWR (max)		1.20			1.20			1.38
Return Loss (min)	(dB)	(20.8)			(20.8)			(15.9)
Isolation (min)	dB	70						
E-Field Shielding Effectiveness (min)	dB	70						60

**SCHEMATICS & DRAWINGS**

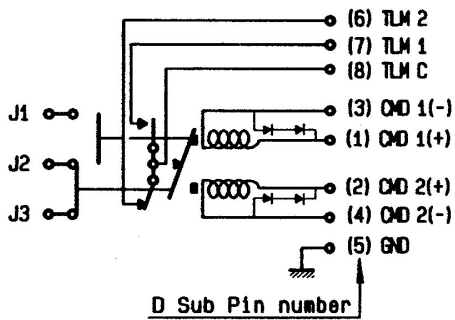

**Position 1 : J1 - J2**  
**Position 2 : J2 - J3**



SPDT lay down with D-sub, variant 001 and 002

**POWER DERATING GRAPH**

VARIANT 001, HIGH CAVITY

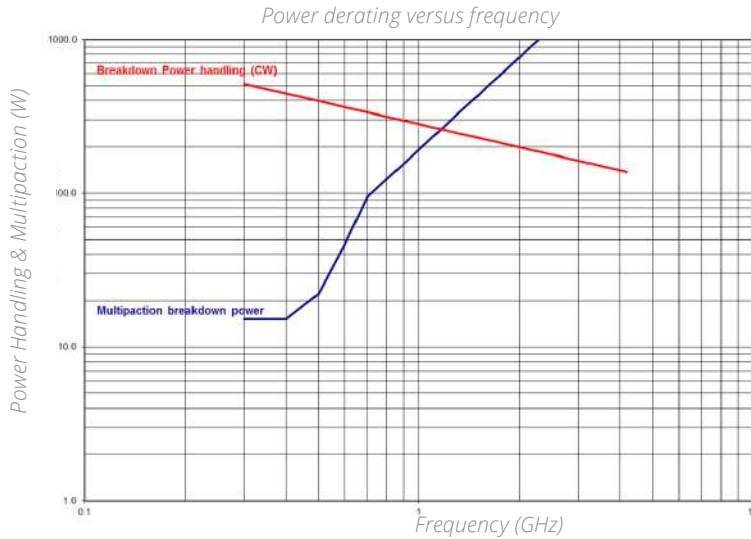

Frequency (GHz)	Breakdown Power handling (W)	Breakdown Multipaction Power (W)
0.3	514.7	15.2
0.4	445.8	15.2
0.5	398.7	22.3
0.6	354.0	46.2
0.7	337.0	94.1
0.8	315.2	122.9
0.9	297.2	155.6
1.0	281.9	192.1
1.1	268.8	232.4
1.2	257.4	275.6
1.3	247.3	324.6
1.4	238.3	375.5
1.5	230.2	432.2
1.6	222.9	491.8
1.7	216.2	555.2
1.8	210.1	622.4
1.9	204.5	693.5
2.0	199.4	768.4
2.2	190.1	929.8
2.4	182.0	1106.5
2.6	174.8	1298.6
2.8	168.5	1506.1
3.0	162.8	1728.9
3.5	150.7	2353.2
4.0	141.0	3073.6
4.2	137.6	3368.6

VARIANT 002, STANDARD CAVITY

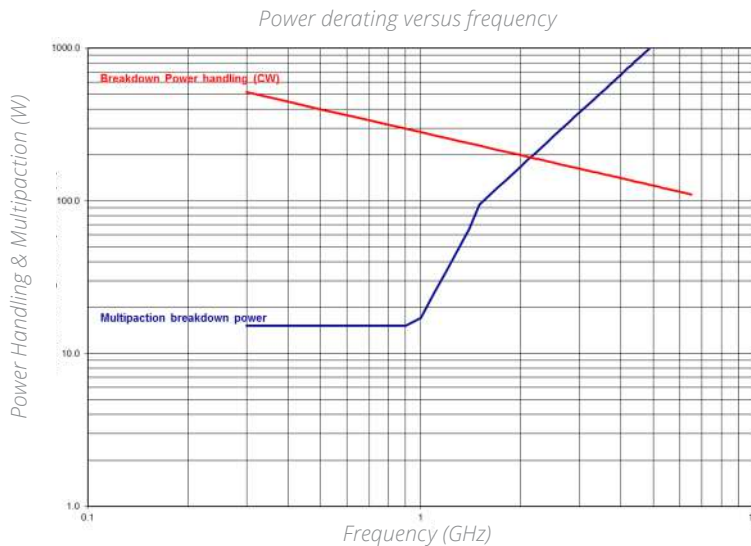

Frequency (GHz)	Breakdown Power handling (W)	Breakdown Multipaction Power (W)
0.3	514.7	15.2
0.9	297.2	15.2
1.0	281.9	17.1
1.1	268.8	25.1
1.2	257.4	35.5
1.3	247.3	48.9
1.4	238.3	65.8
1.5	230.2	94.7
1.6	222.9	107.8
1.7	216.2	121.7
1.8	210.1	136.4
1.9	204.5	152.0
2.0	199.4	168.4
2.2	190.1	203.8
2.4	182.0	242.5
2.6	174.8	284.6
2.8	168.5	330.1
3.0	162.8	379.0
3.2	157.6	431.2
3.4	152.9	486.8
3.6	148.6	545.7
3.8	144.6	608.0
4.0	141.0	673.7
4.2	137.6	742.8
4.4	134.4	815.2
4.6	131.4	891.0
4.8	128.7	970.1
5.0	126.1	1052.7
5.5	120.2	1273.7
6.0	115.1	1515.5
6.5	110.6	1778.0

## HIGH POWER COAXIAL DP3T SWITCH



High power latching Coaxial DP3T Switch according to Radiall specification RAD-DET-DP3T-002:

- TNC connectors
- Up to 2.2 GHz, with 160 Watts CW
- Up to 4.8 GHz, with 150 Watts CW
- Telemetry circuit
- Suppression diodes
- D-Sub or pins
- Lay down
- 390 g and up

### GENERAL SPECIFICATIONS

	UNIT	MIN	TYPICAL	MAX
<b>Actuation Voltage</b>	V	+20	+26	+30
<b>Pick-Up Voltage</b>	V	-	-	+19
<b>Actuation Current</b>	mA	-	-	-
at +29 V, +25 °C		178	188	198
at +29 V, -30 °C		227	239	251
at +29 V, +85 °C		145	153	161
<b>Switching Time</b>	ms	-	25	35
<b>Pulse Duration</b>	ms	50	-	1,000
<b>Coil Resistance (at +25 °C)</b>	Ω	152	160	168
<b>RF Contact Resistance</b>	mΩ	-	-	100
<b>TLM Indicator Circuit</b>	-	-	-	-
Contact Closed	mΩ	-	-	1,000
Contact Open	MΩ	2	-	-
Contact Current	mA	-	-	100
<b>Coil Isolation at 500 VDC</b>	MΩ	1	-	-
<b>Dielectric Withstanding at 50 or 60 Hz</b>	Vrms	500	-	-
<b>Mass</b>	g	-	-	-
Variant 001: Lay down D-Sub		-	-	460
Variant 002: Lay down D-Sub Variant		-	-	445
003: Lay down pins		-	-	390
<b>Torque Screws for:</b>	N.m	-	-	-
Fixing unit		-	-	2.0
D-sub connector		0.27	-	0.44
RF connector		1.7	-	2.65

### RF PERFORMANCE

FREQUENCY	GHZ	DC - 2.2 GHz Variant 001			DC - 4.8 GHz Variant 002 and 003			
		0.04 - 1.0	1.0 - 1.6	1.6 - 2.2	0.04 - 1.0	1.0 - 1.6	1.6 - 2.2	2.2 - 4.8
Insertion Loss (max)	dB	0.12			0.12			0.22
VSWR (max)		1.20			1.20			1.38
Return Loss (min)	(dB)	(20.8)			(20.8)			(15.9)
Isolation (min)	dB	70						
E-Field Shielding Effectiveness (min)	dB	70						60



**SCHEMATICS & DRAWINGS**

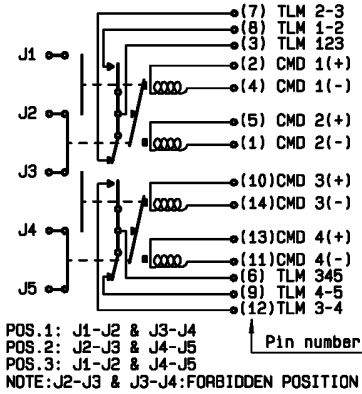

DP3T, lay down with pins

**POWER DERATING GRAPH**

VARIANT 001, HIGH CAVITY

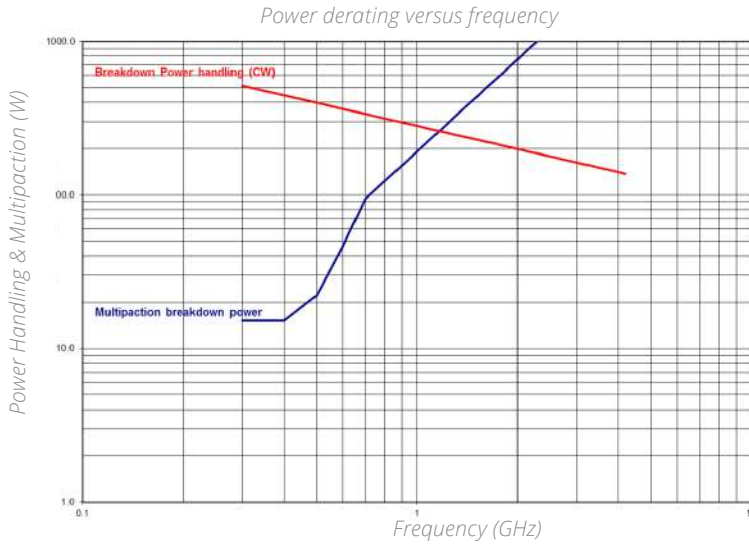

Frequency (GHz)	Breakdown Power handling (W)	Breakdown Multipaction Power (W)
0.3	514.7	15.2
0.4	445.8	15.2
0.5	398.7	22.3
0.6	354.0	46.2
0.7	317.0	94.1
0.8	281.2	122.9
0.9	247.2	155.6
1.0	214.9	192.1
1.1	184.8	232.4
1.2	157.4	276.5
1.3	132.3	324.6
1.4	109.3	375.5
1.5	89.2	430.2
1.6	72.9	491.9
1.7	59.2	555.2
1.8	48.1	622.4
1.9	39.5	693.5
2.0	33.4	768.4
2.2	25.1	929.8
2.4	18.0	1106.5
2.6	14.8	1299.6
2.8	12.5	1506.1
3.0	10.8	1728.9
3.5	7.7	2353.2
4.0	5.0	3073.6
4.2	4.6	3388.6

VARIANT 002, STANDARD CAVITY

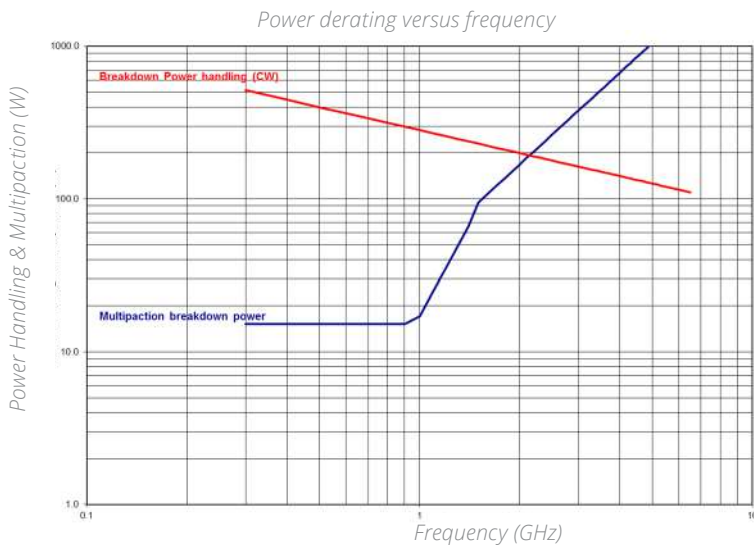

Frequency (GHz)	Breakdown Power handling (W)	Breakdown Multipaction Power (W)
0.3	514.7	15.2
0.9	297.2	15.2
1.0	281.9	17.1
1.1	268.8	25.1
1.2	257.4	35.5
1.3	247.3	48.9
1.4	238.3	65.8
1.5	230.2	94.7
1.6	222.9	107.8
1.7	216.2	121.7
1.8	210.1	136.4
1.9	204.5	152.0
2.0	199.4	168.4
2.2	190.1	203.8
2.4	182.0	242.5
2.6	174.8	284.6
2.8	168.5	330.1
3.0	162.8	379.0
3.2	157.6	431.2
3.4	152.9	486.8
3.6	148.6	545.7
3.8	144.6	608.0
4.0	141.0	673.7
4.2	137.6	742.8
4.4	134.4	815.2
4.6	131.4	891.0
4.8	128.7	970.1
5.0	126.1	1052.7
5.5	120.2	1273.7
6.0	115.1	1515.9
6.5	110.6	1779.0

## HIGH POWER COAXIAL T-SWITCH



High power latching Coaxial T-Switch according to Radiall specification RAD-DET-TSRD-002:

- TNC connectors
- DC to 8 GHz
- Up to 120 Watts CW at 4 GHz
- Random Drive
- Telemetry circuit
- Suppression diodes
- D-Sub or solder pins
- Lay down or Stand up
- 355 grams and up

### GENERAL SPECIFICATIONS

	UNIT	MIN	TYPICAL	MAX
<b>Actuation Voltage</b>	V	+22	+26	+29
<b>Pick-Up Voltage</b>	V	-	-	+20.5
<b>Actuation Current</b>	mA	-	-	-
at +29 V, +25 °C		450	470	490
at +29 V, -25 °C		555	585	610
at +29 V, -30 °C		570	595	620
at +29 V, +80 °C		360	385	405
at +29 V, -85 °C		365	380	397
<b>Switching Time</b>	ms	-	-	35
<b>Pulse Duration</b>	ms	35	-	1,000
<b>Coil Resistance (at +25 °C)</b>	Ω	59.3	61.8	64.4
<b>RF Contact Resistance</b>	mΩ	-	-	100
<b>TLM Indicator Circuit</b>	-	-	-	-
Contact Closed	mΩ	-	-	1,000
Contact Open	MΩ	1	-	-
Contact Current	mA	-	-	100
<b>Coil Isolation at 500 VDC</b>	MΩ	1	-	-
<b>Dielectric Withstanding at 50 or 60 Hz</b>	Vrms	500	-	-
<b>Mass</b>	g	-	-	-
Variant 001: T-Switch, Lay down, D-Sub		-	-	360
Variant 002: T-Switch, Stand up, D-Sub		-	-	355
<b>Torque Screws for:</b>	N.m	-	-	-
Fixing unit		-	-	2.0
D-sub connector		0.27	-	0.44
RF connector		1.7	-	2.65

### RF PERFORMANCE

DC - 8 GHz Variants 001 and 002

FREQUENCY	GHZ	DC - 2	2 - 4.8	4.8 - 6	6 - 8
Insertion Loss (max)	dB	0.17	0.20	0.30	0.40
VSWR (max)	(dB)	1.10	1.25	1.35	1.50
Return Loss (min)		(26.4)	(19.1)	(16.5)	(14)
Isolation (min)	dB	70			
E-Field Shielding Effectiveness (min)	dB	75			70

Flight Models

SCHEMATICS & DRAWINGS

T-SWITCH, TNC, D-SUB, VARIANT 001 & 002:

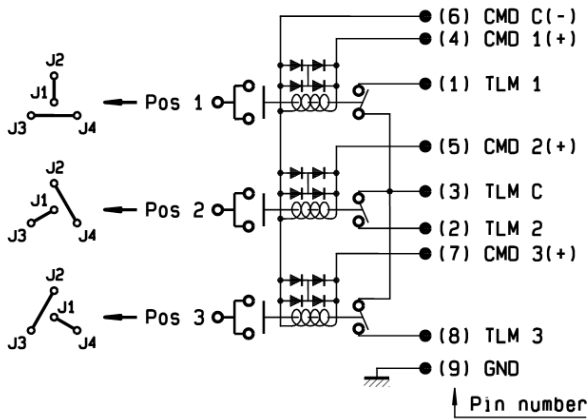

T-Switch, Lay down with D-sub, variant 001



T-Switch, Stand up with D-sub, variant 002

POWER DERATING GRAPH

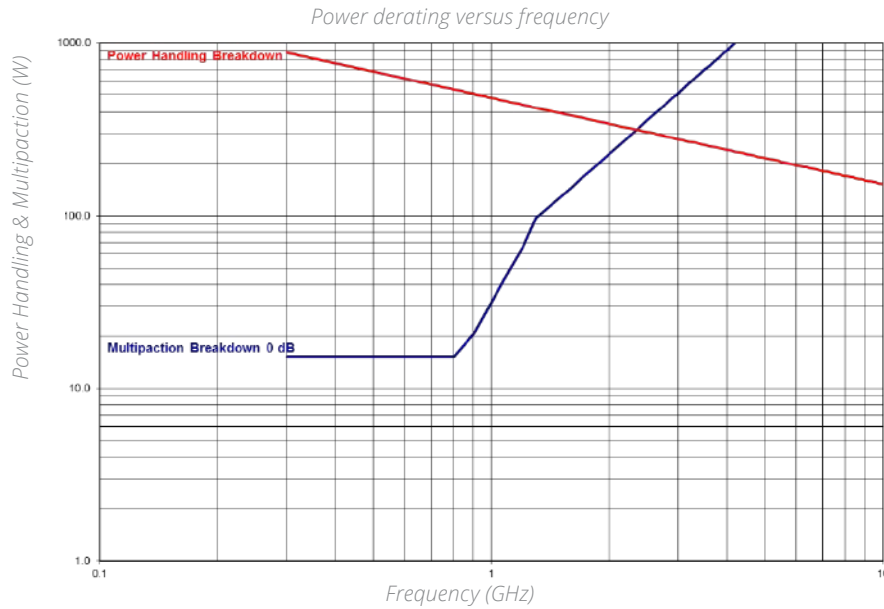

Frequency (GHz)	Breakdown Power Handling (W)	Breakdown Multipaction Power (W)
0.3	880.0	15.2
0.4	762.1	15.2
0.5	681.6	15.2
0.6	622.3	15.2
0.7	576.1	15.2
0.8	538.9	15.2
0.9	508.1	20.7
1	482.0	31.5
1.1	459.6	46.2
1.2	440.0	65.4
1.3	422.7	96.6
1.4	407.4	112.0
1.5	393.5	128.6
1.6	381.1	146.3
1.7	369.7	165.2
1.8	359.3	185.2
1.9	349.7	206.3
2	340.8	228.6
2.1	332.6	252.0
2.2	325.0	276.6
2.3	317.8	302.3
2.4	311.1	329.2
2.5	304.8	357.2
2.6	298.9	386.4
2.7	293.3	416.6

## GENERAL INFORMATION



With more than 25 years of experience in the space industry, Radiall has developed a product offering that emphasizes reliability and performance. The latest addition to the range includes SPDT, DPDT and SPnT RF switches designed to operate in thermal vacuum environments. These products can be mounted on ground based test benches, used in test equipment, and space vacuum conditions.

Tvac Series switches are designed in accordance with our standard RAMSES product offering and offer identical configurations with excellent performance.

## PART NUMBER SELECTION

"6 standard models are available for test benches dedicated to space equipment in Thermal Vacuum environments"

- 22 GHz SPDT coaxial switch: R571 F63 121
- 22 GHz DPDT coaxial switch: R578 F63 121
- 22 GHz non-terminated SP6T coaxial switch: R583 F33 121
- 40 GHz SPDT coaxial switch: R571 863 121
- 40 GHz DPDT coaxial switch: R578 863 121
- 40 GHz non-terminated SP6T coaxial switch: R583 833 121

OPERATING MODE	LATCHING	
Nominal operating voltage (across operating temperature)	Vdc	28 (24/30)
Coil resistance (+/-10%)	$\Omega$	DPDT and SP6T: 225 / SPDT: 350
Nominal operating current at 23°	mA	DPDT and SP6T: 125 / SPDT: 80
Average power (Thermal vacuum condition)	See power rating chart on page 7-20	
Switching time (max)	SPDT and DPDT: 10 ms / SP6T: 15 ms	
SMA - SMA 2.9	SPDT	10 million cycles
SMA - SMA 2.9	DPDT	2.5 million cycles
SMA - SMA 2.9	SP6T	5 million cycles / 2 million cycles
Connectors <sup>(1)</sup>	SMA / SMA 2.9	

### Notes

Terminated models are also available

SPnT models are only available with separated reset option

1. Connector SMA 2.9 is equivalent to "K connector<sup>®</sup>", registered trademark of Anritsu.

## Thermal Vacuum Switches for Ground Segments

### ADDITIONAL SPECIFICATION

POLARITY		POSITIVE COMMON
Actuator terminals	SPDT	Solder Pins
	DPDT	Male 9 pins D-Sub connector
	SP6T	Male 25 pins D-Sub connector
Operating temperature range		-40 °C to 85 °C
Storage temperature range		-55 °C to 85 °C
Construction		Thermal vacuum compatible

### SMA CONNECTOR

SWITCH MODEL	FREQUENCY RANGE GHz	V.S.W.R. (MAX)	INSERTION LOSS (MAX) dB	ISOLATION (MIN) dB	IMPEDANCE $\Omega$	AVERAGE POWER <sup>(1)</sup> W	REPEATABILITY
SPDT	DC - 22	DC - 3	1.20	0.20	80	240	0.03 dB peak change in Insertion Loss over 100 cycles
		3 - 8	1.30	0.30	70	150	
		8 - 12.4	1.40	0.40	60	120	
		12.4 - 18	1.50	0.50	60	100	
		18 - 22	1.70	0.70	55	40	
DPDT SP6T (non-terminated)	DC - 22	DC - 3	1.20	0.20	80	240	
		3 - 8	1.30	0.30	70	150	
		8 - 12.4	1.40	0.40	60	120	
		12.4 - 18	1.50	0.50	60	100	
		18 - 22	1.70	0.70	50	40	

### SMA 2.9 CONNECTOR

SWITCH MODEL	FREQUENCY RANGE GHz	V.S.W.R. (MAX)	INSERTION LOSS (MAX) dB	ISOLATION (MIN) dB	IMPEDANCE $\Omega$	AVERAGE POWER <sup>(1)</sup> W	REPEATABILITY
SPDT DPDT	DC - 40	DC - 6	1.30	0.30	70	80	0.03 dB peak change in Insertion Loss over 100 cycles
		6 - 12.4	1.40	0.40	60	60	
		12.4 - 18	1.50	0.50	60	50	
		18 - 26.5	1.70	0.70	55	20	
		26.5 - 40	1.90	0.90	50	10	
SP6T (non-terminated)	DC - 40	DC - 6	1.30	0.30	70	40	
		6 - 12.4	1.40	0.40	60	30	
		12.4 - 18	1.50	0.50	60	25	
		18 - 26.5	1.70	0.70	55	15	
		26.5 - 40	1.90	0.90	50	5	

### WHY A THERMAL VACUUM TEST BENCH?

- It limits the need of hermetic adaptors and cable assemblies
- It improves RF performance
- It decreases the complexity of the Test bench

#### Notes

1. Average power at 25 °C per RF path / Sea level.

Thermal Vacuum Switches for Ground Segments

POWER DERATING GRAPH

SPDT, DPDT AND SP6T SMA 22 GHz

Multipactor and Power handling under vacuum (max value)

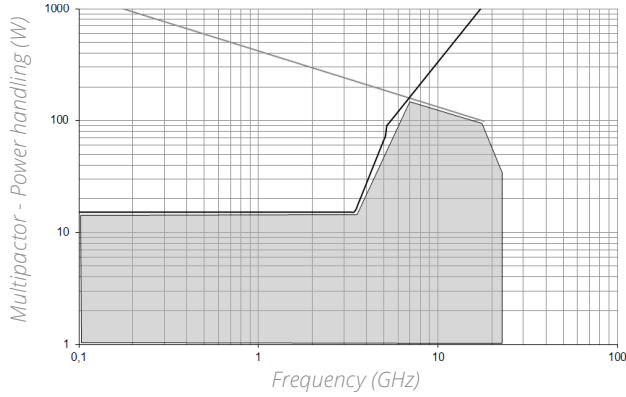

SPDT SMA 2.9 40 GHz

Multipactor and Power handling under vacuum (max value)

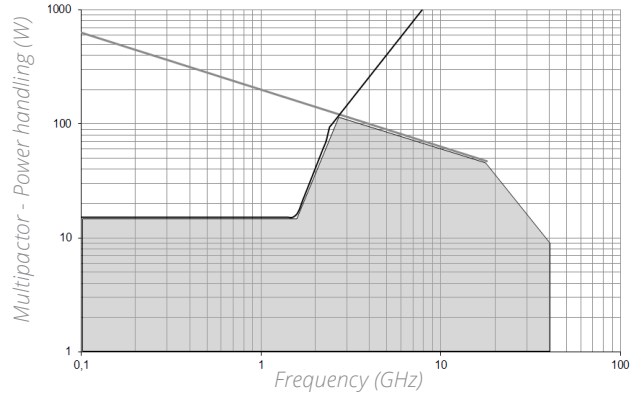

DPDT SMA 2.9 40 GHz

Multipactor and Power handling under vacuum (max value)

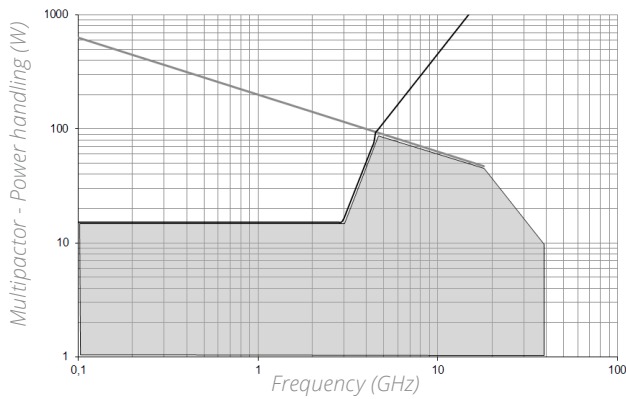

SP6T SMA 2.9 40 GHz

Multipactor and Power handling under vacuum (max value)

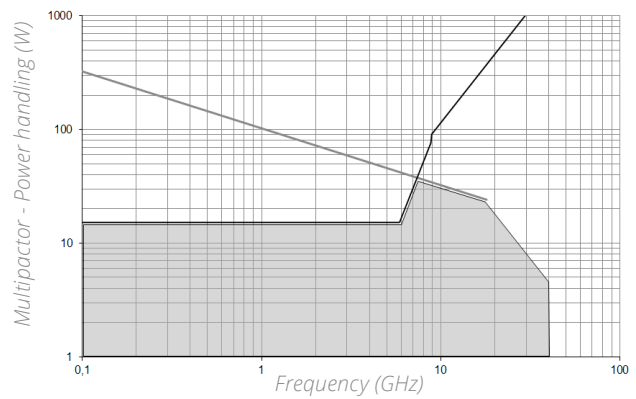

- POWER HANDLING
- MULTIPACTOR
- AVER. POWER CAPABILITY

HERMETIC FEMALE/FEMALE ADAPTATORS



<b>Multipactor threshold</b>	-	-	-
L Band 2 GHz	≥2000	Wpp	Max. tested values, pulse width 20 μs; PRF 1,000 Hz
C Band 8 GHz	≥2000	Wpp	
<b>Power handling</b>	-	-	-
L Band 2 GHz	600	WCW	-
C Band 8 GHz	400	WCW	-

- SMA DC - 18 GHz
- VHP TNC DC - 8 GHz
- ESA qualified
- High reliability

**OTHER**

---





---

*Section 8 Table of Contents***OTHER COMPONENTS**

RF and Microwave Coaxial Products .....	8-2 to 8-3
TestPro Cable Assemblies.....	8-4
Space Qualified Products .....	8-5 to 8-6
Switch Applications .....	8-7 to 8-8

## RF & MICROWAVE COAXIAL PRODUCTS

### GENERAL INFORMATION

Specialized in passive RF & Microwave components, Radiall's engineering staff develops and manufactures a wide range of other coaxial standard devices including: terminations, attenuators, coaxial couplers, detectors, rotary joints, filters, and phase shifters. This range covers a wide frequency spectrum from DC to 50 GHz for telecom, aerospace, instrumentation and military application.

Radiall introduced TestPro cable assemblies into the market for Test & Measurement applications, in order to meet customers' needs.

For Space applications, Radiall also offers a full range of space components built according to ESA specifications including; attenuators, terminations, couplers, connectors, coaxial cable assemblies (flexible or semi-rigid cables) for L, S, C, X, Ku and Ka band applications.

### TERMINATIONS

Radiall's range of terminations is intended to terminate a coaxial transmission through characteristic impedance and dissipating the RF incident power. The main features of our full range of terminations include:

- Power range from 0.5 W to 1000 W
- Frequency from DC up to 50 GHz
- 50  $\Omega$  Impedance
- High repeatability
- Compatibility with Broad type connections: BMA, BNC, QMA, QN, N, SMA, SMA 2.9, SMB, SMP, SSMA, TNC, 1.0/2.3, 7/16, 2.4 mm
- Connector interface according to applicable MIL, DIN, NF and CEI
- Dedicated range for Test & Measurement with the lowest VSWR



### ATTENUATORS

Attenuators are linear passive transition line components designed to be inserted between two coaxial lines to reduce the input power in a matched system by a predetermined ratio. This ratio is expressed in logarithmic terms. 3 dB as a power ratio is 2, 6 dB is 4, 20 dB is 100, and 30 dB is 1,000. The main features of our full range of coaxial attenuators include:

- Power range from 1 W to 100 W
- Frequency from DC up to 40 GHz
- High repeatability
- 50  $\Omega$  Impedance
- Compatibility with Broad type connections : BNC, QN, N, SMA, SMA 2.9, SMB, TNC, 7/16
- Connector interface according to applicable MIL, DIN, NF and CEI
- Dedicated range for Test & Measurement with the lowest VSWR



## Other Components

### COAXIAL COUPLERS

Radiall's coaxial couplers offer a reliable design to meet the needs of microwave applications. The main features of our full range of coaxial couplers include:

- Directional and 3dB Hybrid 90° couplers
- Power range from 50 to 500 Watts
- Frequency from 0.15 GHz to 8 GHz
- 6, 10, 20 and 30 dB coupling factors
- SMA, Type N offered, TNC 7/16
- Dedicated range providing flat frequency response
- Possibility to design custom coaxial couplers as per customer requirements



### SPECIAL MICROWAVE COMPONENTS

Radiall offers a complete range of special Microwave components suitable for applications utilizing the following devices:

- Feedthrough terminations
- Detectors
- Rotary joints
- DC Blocks
- Monitor tees
- Signal samplers
- Phase shifters
- Filters



#### *Feed through terminations*

These components are used to properly terminate a transmission line while testing with a high impedance measuring system such as an oscilloscope input.

#### *Detectors*

A detector is a two port device capable of supplying a low frequency signal on its output port (video), of a level proportional to the RF power applied to its input port.

#### *Rotary joints*

These components provide the transition between two coaxial transmission lines that rotate while maintaining necessary RF characteristics.

#### *DC blocks*

DC blocks are composed of a capacitor inserted to the central conductor of the coaxial line. They block any DC or low frequency current present in the line.

#### *Signal samplers*

These devices are used to sample part of an RF signal from a coaxial line. They are not directive, and the sample incident reflects energy.

#### *Phase shifters*

These components create a mechanical adjustable phase shift by variation in the physical length of the transmission line.

## TESTPRO CABLE ASSEMBLIES



TestPro cables are dedicated to bench test cable assemblies. Our TestPro range differs from the SHF range, because the cables and connectors are designed for high performance and testing and measurement.

While others propose cosmetic solutions to appear more robust without any real performance advantages, Radiall's design offers a full range of test bench cables that performs better than any other product on the market.

Test cable assemblies are intended for daily use in component and assembly shops, test labs and automatic test equipment applications. They differ from standard cable assemblies in that they are specifically designed for applications that require repeated connect/disconnect procedures, strenuous flexing situations and applications where cable and connector durability is important.

### Key characteristics of the TestPro range include:

- Rugged interface: 5,000 mating/unmating lifecycle
- Flex life: over 20,000 cycles
- High flexibility
- Outstanding phase and loss stability for long calibration intervals

	TESTPRO 4.2	TESTPRO 3	TESTPRO 2
Frequency	DC - 18 GHz	DC - 26.5 GHz / DC - 40 GHz	DC - 50 GHz / DC - 67 GHz
Impedance	50 $\Omega$ $\pm$ 2 $\Omega$	50 $\Omega$ $\pm$ 1 $\Omega$	50 $\Omega$ $\pm$ 1 $\Omega$
IL (dB/m)	2.10 at 18 GHz	2.41 at 26.5 GHz - 3.11 at 40 GHz	5.00 at 50 GHz - 5.92 at 67 GHz
Test IL (dB/ft)	0.64 at 18 GHz	0.73 at 26.5 GHz - 0.94 at 40 GHz	1.52 at 50 GHz - 1.80 at 67 GHz
Phase with flexure stability	2° at 18 GHz	2° at 26.5 GHz - 5° at 40 GHz	6° at 50 GHz - 8° at 67 GHz
Amplitude stability (dB)	0.05 at 18 GHz	0.05 at 40 GHz	0.05 at 50 GHz
Shielding Effectiveness	-110 dB min at 1 GHz	-100 dB min at 1 GHz	-100 dB min at 1 GHz
Crush resistance	135 lb / linear in.	260 lb / linear in.	260 lb / linear in.
Minimum bend radius	25 mm (1 in.)	25 mm (1 in.)	25 mm (1 in.)
Temperature (°C)	-55 / + 125 °C	-55 / + 125 °C	-55 / + 125 °C
Connectors	SMA, N, TNC, PC7	SMA 3.5, SMA 2.9, NMD 2.9, TVAC 2.9, SMA 2.4 mm, N	2.4 mm/1.85 mm
Flexure life cycle	10,000	20,000	20,000
Mating cycles durability	5,000	5,000	5,000
Armor	Available	Integrated	Integrated
RoHS/REACH	Yes	Yes	Yes

### Notes

Please refer to TestPro catalog D1A295TE.

## SPACE QUALIFIED PRODUCTS

### COAXIAL CONNECTORS

Full range of coaxial connectors operating up to Q band.

- SMA, SMA 2.9 and Very High Power TNC interfaces ESCC QPL:
- Qualified according to ESCC 3402 specifications by European Space Agency (ESA)
- TNC and SMP interfaces classified EPPL: ESA Preferred Part List

Radiall has expanded the SMP range to include, SMP-LOCK® connectors featuring a robust locking mechanism. Qualified for space applications, this new interface is the best solution when size, weight, security and high RF performance are required.

This new interface is compatible with most of Radiall products below.

- 2.4 mm interface up to 50 GHz

### LOW LOSSES CABLE ASSEMBLIES

*Space qualified low loss flexible coaxial cable assemblies up to 40 GHz*

- Available connectors: SMA, SMA 2.9, TNC, Very High Power TNC (ESA QPL), SMP or SMP-LOCK®

### SEMI-RIGID CABLE ASSEMBLIES

*Space qualified semi-rigid coaxial cable assemblies up to 40 GHz*

- Available connectors: SMA, SMA 2.9, TNC, Very High Power TNC, SMP or SMP-LOCK®

### COUPLERS & POWER DIVIDERS

*Space qualified passive couplers DC-22 GHz and power dividers DC-31 GHz*

- Admissible power up to 200 WCW
- Available connectors: SMA, SMA 2.9 and TNC



Other Components

**COAXIAL SWITCHES**

A full range of lightweight Space qualified switches operating up to the Ka band.

- SPDT, DPDT, DP3T and T-Switch configurations available
- Available connectors: SMA, SMA 2.9 and TNC

**TERMINATIONS**

Range of low power coaxial loads up to 40 GHz and ESA qualified (European Space Agency).

- Available connectors: SMA, SMA 2.9, SMP, SMP LOCK® and TNC interface.

**ATTENUATORS**

Range of low power coaxial attenuators DC - 40 GHz and qualified by European Space Agency (ESA).

- Available connectors: SMA, SMA 2.9 and SMP LOCK® interface.
- Attenuation 0 to 30 dB.

**PHASE SHIFTERS**

These components create a mechanical adjustable phase shift by variation in the physical length of the transmission line up to 22 GHz.

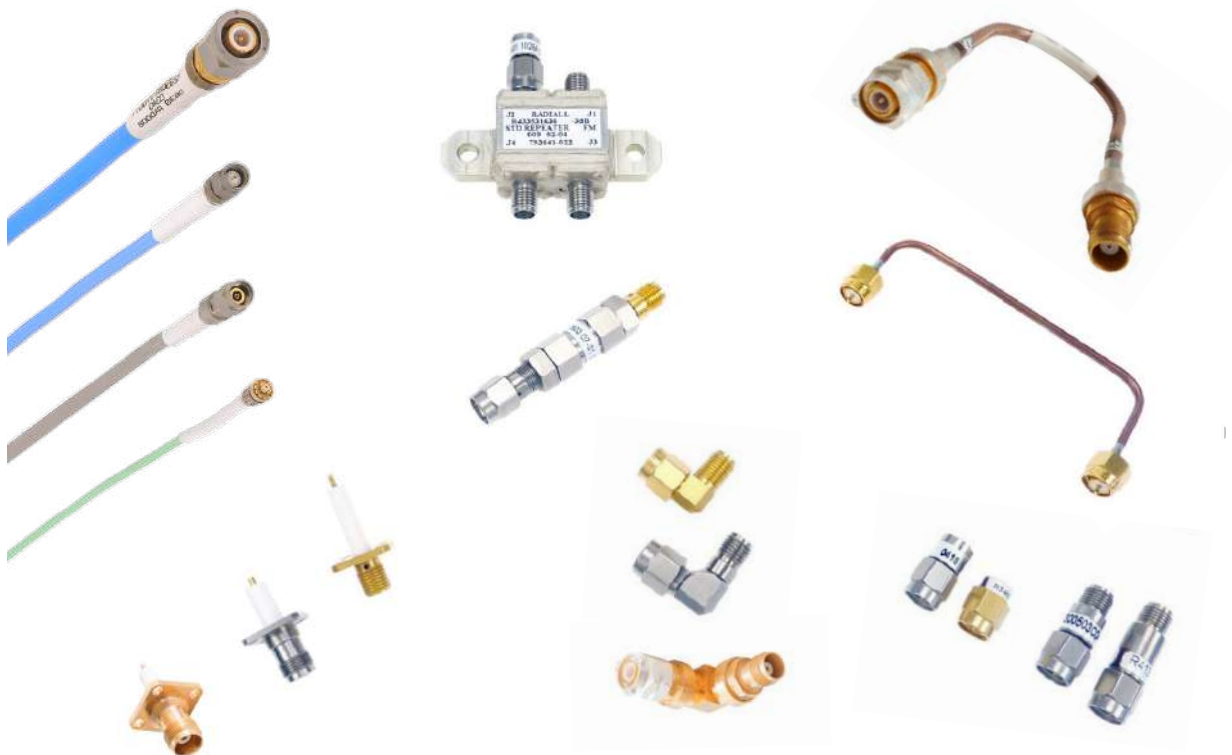

## SWITCHES APPLICATIONS

### COAXIAL TRANSFER SWITCHES (DPDT)

A DPDT is Double Pole Double Throw switch that provides two independent pairs of RF paths that are actuated simultaneously. The transfer switch is a modified DPDT device, whereas a true DPDT switch is a six port device that contains completely independent transmission paths.

In a transfer switch, two transmission paths are not completely independent as shown below:

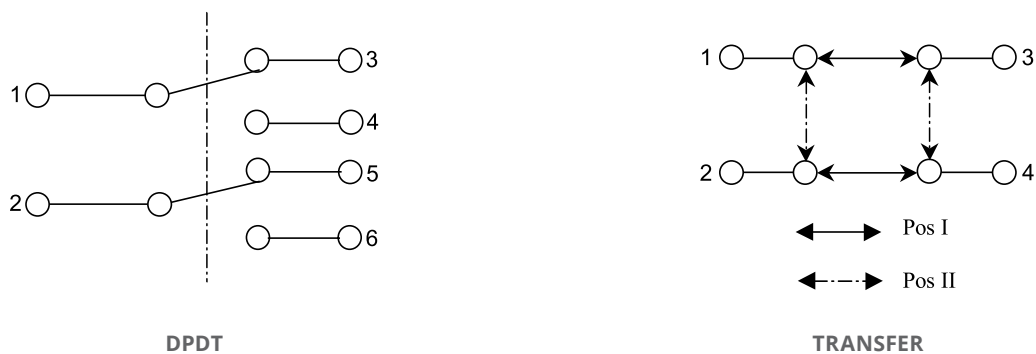

#### Examples of transfer switch applications:

R577 RAMSES, R593 Platinum or R513 Titanium series can be selected for this application.

#### REDUNDANCY OF TWO TRANSMITTERS

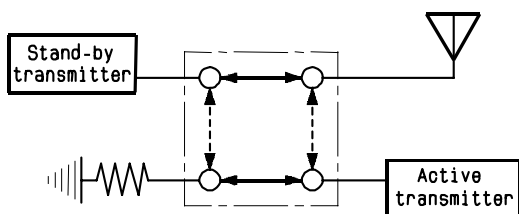

Active transmitters are connected directly to the antenna. A second transmitter is terminated to a medium power termination and put in stand by position; ready to switch to the antenna in case of a failure of the active transmitter. This is done to create redundancy for antenna maintenance.

#### TWO TRANSMITTERS TO TWO ANTENNAS

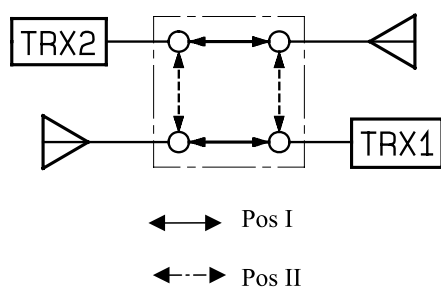

For better signal diversity, two antennas are alternately connected to either of the two transmitters.

Other Components

COAXIAL TRANSFER AS A BYPASS SWITCH FOR CIRCUIT INSERTION APPLICATIONS

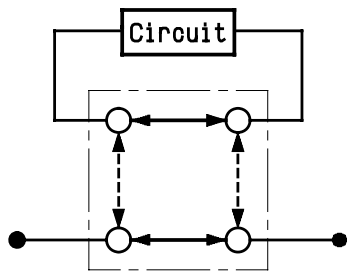

A full RF or microwave passive circuit or circuit element as a filter can be inserted into a coaxial transmission line by using a transfer switch. This element is shorted by a transfer blade in through position.

OTHER RF ARRANGEMENTS FOR A BYPASS FUNCTION

- Two SPDT switches configured to operate as a bypass switch.
- R570 RAMSES, R596 (Surface Mount Technology) or R595 PLATINUM series can be used to achieve a bypass function.

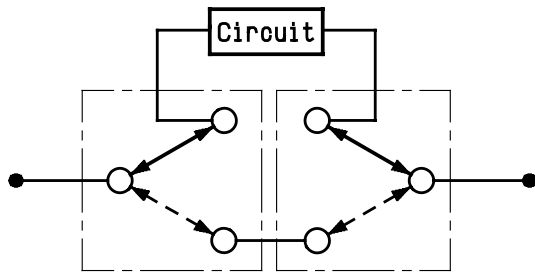

A more basic option, SPDT (Single Pole Double Throw) can be used to perform a bypass switch function. The advantage of using two SPDT relays instead of a transfer switch is a possible reduction in total package size. Generally, the use of two SPDT creates a higher isolation than a transfer switch.

A DP3T SWITCH CONFIGURED TO OPERATE AS A TRANSFER SWITCH

A R585 RAMSES or R595 Platinum series can be selected to insert a passive or active component or circuit in a RF or microwave line.

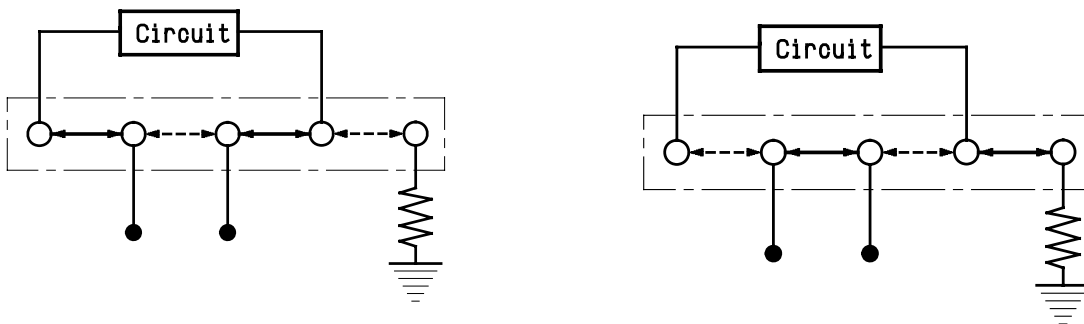

An active component as an amplifier can be inserted in a microwave line; this amplifier is connected to a 50 Ohm termination (as a booster in stand-by status) when not inserted in the main coaxial line.



# NAVIGATOR

---

Coaxial Switches Navigator

Family	Series	RF Type (Switch Configuration)	Frequency <sup>(1)</sup>										Connector Type	Number of Connector Ports	Actuator Type			Indicator Circuit	TIL Drive	Self Cut-off □ = / Latching	Diodes	Repeatability Guarantee (dB)	RF Terminated IL = Internal loads EL = External loads	Life Cycles (Million)					
			2.5 GHz	3 GHz	6 GHz	8 GHz	12.4 GHz	18 GHz	20 GHz	22 GHz	26.5 GHz	40 GHz			50 GHz	Normally Open	Latching								Failsafe				
RAMSES	R573 & R574	SPnT	J										2.4 mm	4 or 6 ways	■	■	-	12/28	■	■	■	■	-	IL	2				
			8										SMA 2.9	3 - 6 ways	■	■	-	12/28	■	■	□	■	-	IL	2				
			3	4 or F <sub>o</sub>		F <sub>o</sub>	F							SMA	3 - 8 ways 12 ways $\circ$ 10 ways $\diamond$	■	■	-	12/28	■	■	□	■	-	IL	2			
			E											QMA	3 - 6 ways	■	■	-	12/28	■	■	□	■	-	-	5			
			9										DIN 1.6/5.6 <sup>(2)</sup>	3 - 6 ways	■	■	-	12/28	■	■	□	■	-	-	5				
			0	1 <sup>□</sup>	1								N	3 - 6 ways 7 - 12 ways <sup>□</sup>	■	■	-	12/28	■	■	□	■	-	IL	2				
			2										BNC	3 - 6 ways	■	■	-	12/28	■	■	□	■	-	-	2				
			5	6									TNC	3 - 6 ways	■	■	-	12/28	■	■	□	■	-	-	2				
	R570	SPDT	J										2.4 mm	3 ports	-	■	■	12/28	■	■	■	■	-	-	2				
			8										SMA 2.9	3 ports	-	■	■	12/28	■	■	■	■	-	-	10				
			3	4		F							SMA	3 ports	-	■	■	12/28	■	■	■	■	-	-	10				
			E											QMA	3 ports	-	■	■	12/28	■	■	■	■	-	-	10			
			9										DIN 1.6/5.6 <sup>(2)</sup>	3 ports	-	■	■	12/28	■	■	■	■	-	-	5				
			A										PC Board Mount	3 ports	-	■	■	12/28	■	■	■	■	-	-	5				
			0	1									N	3 ports	-	■	■	12/28	■	■	■	■	-	-	2.5				
			5	6		D							TNC	3 ports	-	■	■	12/28	■	■	■	■	-	-	2.5				
	2										BNC	3 ports	-	■	■	12/28	■	■	■	■	-	-	2.5						
	R577	DPDT	J										2.4 mm	4 ports	-	■	■	12/28	■	■	■	■	-	-	2				
			8										SMA 2.9	4 ports	-	■	■	12/28	■	■	■	■	-	-	2.5				
			3	4		F							SMA	4 ports	-	■	■	12/28	■	■	■	■	-	-	2.5				
E												QMA	4 ports	-	■	■	12/28	■	■	■	■	-	-	2.5					
9												DIN 1.6/5.6 <sup>(2)</sup>	4 ports	-	■	■	12/28	■	■	■	■	-	-	2.5					
0			1									N	4 ports	-	■	■	12/28	■	■	■	■	-	-	2.5					
5			6								TNC	4 ports	-	■	■	12/28	■	■	■	■	-	-	2.5						
2												BNC	4 ports	-	■	■	12/28	■	■	■	■	-	-	2.5					
R585	SPDT ZC (ZC=terminated)	J										2.4 mm	5 ports	■	■	■	12/28	■	■	■	■	-	2 EL	2					
		8										SMA 2.9	3 or 5 ports	■	■	■	12/28	■	■	■	■	-	2 EL	10					
		3	4		F							SMA	3 or 5 ports	■	■	■	12/28	■	■	■	■	-	2 EL	10					
		E											QMA	4 ports	-	■	■	12/28	■	■	■	■	-	2 IL	2				
	DP3T	J										2.4 mm	5 ports	■	■	■	12/28	■	■	■	■	-	-	2					
		8										SMA 2.9	5 ports	■	■	■	12/28	■	■	■	■	-	-	10					
		3	4		F							SMA	5 ports	■	■	■	12/28	■	■	■	■	-	-	10					
		E											QMA	4 ports	-	■	■	12/28	■	■	■	■	-	-	10				
BYPASS	J										2.4 mm	4 ports	■	■	■	12/28	■	■	■	■	-	EL	2						
	8										SMA 2.9	4 ports	■	■	■	12/28	■	■	■	■	-	EL	10						
	3	4		F							SMA	4 ports	■	■	■	12/28	■	■	■	■	-	EL	10						
	E											QMA	4 ports	-	■	■	12/28	■	■	■	■	-	-	10					
USB	R573xxxx01 R574xxxx01	SPnT	8										SMA 2.9	6 or 8 ways	■	-	-	5	■	-	-	-	-	IL	2				
			F										SMA	6 or 8 ways	■	-	-	5	■	-	-	-	-	IL	2				
																			-	-	-	-	-	-	-	-	-	-	5

Coaxial Switches Navigator

Family	Series	RF Type (Switch Configuration)	Frequency <sup>(1)</sup>										Connector Type	Number of Connector Ports	Actuator Type			Indicator Circuit	TIL Drive □ = If Normally Open	Self Cut-off	Diodes	Repeatability Guarantee (dB)	RF Terminated IL = Internal loads EL = External loads	Life Cycles (Million)		
			2.5 GHz	3 GHz	6 GHz	8 GHz	12.4 GHz	18 GHz	20 GHz	22 GHz	26.5 GHz	40 GHz			50 GHz	Normally Open	Latching								Failsafe	
SUBMINIATURE	R591	SPnT	3			F							SMA	4 - 6 ways	■	■	-	12/28	-	□	-	■	-	-	10	
			E										QMA	4 - 6 ways	■	■	-	12/28	-	□	-	■	-	-	10	
						8							SMA 2.9	4 - 6 ways	■	■	-	12/28	-	□	-	■	-	-	2	
PLATINUM	R593	DPDT	3			4		F					SMA	4 ports	-	■	-	24	■	■	■	■	.03	-	10	
						8							SMA 2.9	4 ports	-	■	-	24	■	■	■	■	.03	-	5	
	R594	SPnT	3			4		F					SMA	4 - 6 ways	-	■	-	24	■	■	■	■	.03	IL	10	
						8							SMA 2.9	4 - 6 ways	-	■	-	24	■	■	■	■	.03	IL	2	
	R595	SPDT				8							SMA 2.9	3 ports	-	■	-	15/24	■	■	■	■	.05	-	10	
			3			4		F					SMA	3 ports	-	■	-	15/24	■	■	■	■	.03	-	10	
						8							SMA 2.9	5 ports	-	■	-	15/24	■	■	■	■	.05	2 EL	2.5	
			3			4		F					SMA	3 ports	-	■	-	15/24	■	■	■	■	.03	2 IL	10	
						8							SMA 2.9	5 ports	-	■	-	15/24	■	■	■	■	.05	-	10	
TITANIUM	R513	DPDT	3			4		F					SMA	4 ports	-	■	-	24	■	■	■	■	.05	-	5	
						8							SMA 2.9	4 ports	-	■	-	24	■	■	■	■	.03	-	10	
	R512	SPnT				8							SMA 2.9	4 - 6 ways	-	■	-	24	■	■	■	■	.05	IL	1	
	R514	SPnT	3			4		F					SMA	4 - 6 ways	-	■	-	24	■	■	■	■	.03	IL	2.5	
	QUARTZ	R516	SPDT	3			4		7					-	-	-	■ <sup>(3)</sup>	12/24	-	-	-	-	-	-	-	3
							4							SMA	3 ports	-	■	■	■	■	■	-	-	-	2	
				1										N	3 ports	-	■	■	■	■	■	-	-	-	2	
							4							SMA	4 ports	-	■	■	■	■	■	-	-	-	2	
				1										N	4 ports	-	■	■	■	■	■	-	-	-	2	
LOW PIM	R570xxxxxxLP	SPDT				4							SMA	3 ports	-	■	■	■	■	■	-	-	-	2		
			1										N	3 ports	-	■	■	■	■	■	-	-	-	2		
	R577xxxxxxLP	DPDT				4							SMA	4 ports	-	■	■	■	■	■	-	-	-	2		
			1										N	4 ports	-	■	■	■	■	■	-	-	-	2		
	R573xxxxxxLP	SPnT				4							SMA	4 or 6 ports	■	■	-	12/28	■	■	■	■	-	-	2	
			1										N	4 or 6 ports	■	■	-	12/28	■	■	■	■	-	-	2	
TVAC	R571	SPDT				F							SMA	3 ports	-	■	-	28	■	-	■	■	-	-	10	
						8							SMA 2.9	3 ports	-	■	-	28	■	-	■	■	-	-	10	
	R578	DPDT				F							SMA	4 ports	-	■	-	28	■	-	■	■	-	-	2.5	
						8							SMA 2.9	4 ports	-	■	-	28	■	-	■	■	-	-	2.5	
	R583 & R584	SPnT				F							SMA	4 or 6 ways	-	■	-	28	■	-	-	-	-	-	IL	2
			8							SMA 2.9	4 or 6 ways	-	■	-	28	■	-	-	-	-	-	IL	2			

Notes

Please consult the Coaxial Switches catalog for other P/N selection digits (including electrical and other options). Switches are break-before-make and 50 Ohms Impedance unless otherwise specified.

1. Corresponds to the 4th digit in the part number (ex: R77 "J" for 50GHz)
2. 75 Ohms products
3. Failsafe inverted RF path also available for Bypass application

# SIMPLIFICATION is our INNOVATION

*We advance the design and engineering process for innovators, ground-breakers and pioneers of technology. We reduce weight, improve durability and streamline installation to provide leading-edge connectors that drive product performance.*

## AREA OFFICES LOCAL CONTACTS

### EUROPE

ADDRESS	PHONE	FAX	EMAIL
<b>FINLAND</b> Radiall Finland PO Box 202, 90101, Oulu	+358407522412		infofi@radiall.com
<b>FRANCE</b> Radiall SA 25 Rue Madeleine Vionnet, 93300, Aubervilliers	+33149353535		info@radiall.com
<b>GERMANY</b> Radiall GmbH Carl-Zeiss-Straße 10, 63322, Rödermark	+49607491070	+496074910710	infode@radiall.com
<b>ITALY</b> Radiall Elettronica S.R.L. Via Zambelletti 19, 20021, Baranzate Milano	+39024885121	+390248843018	infoit@radiall.com
<b>NETHERLANDS</b> Radiall Nederland BV Hogebrinkerweg 15b, 3871, KM Hoevelaken	+31332534009	+31332534512	infofl@radiall.com
<b>SWEDEN</b> Radiall AB Sollentunavägen 63, 191 40 Sollentuna	+4684443410		infose@radiall.com
<b>UNITED KINGDOM</b> Radiall Ltd. Profile West, 950 Great West Rd., Brentford, Middlesex TW8 9ES	+441895425000	+441895425010	infouk@radiall.com

### ASIA

<b>CHINA</b> Shanghai Radiall Electronics Co., Ltd. No.390, Yonghe Road, Shanghai, 200072	+862166523788	+862166521177	infozh@radiall.com
<b>HONG KONG</b> Radiall Electronics (Asia) Ltd. Room A, 16/F., Ford Glory Plaza, 37-39 Wing Hong Street, Cheung Sha Wan, Kowloon, Hong Kong	+85229593833	+85229592636	infohk@radiall.com
<b>INDIA</b> Radiall India Pvt. Ltd. 25D, Phase 2, Peenya Industrial Area, Bengaluru 560 058	+918028395271	+918028397228	infoin@radiall.com
<b>JAPAN</b> Nihon Radiall K.K. Sawada Building 8F, Shibuya-ku, Tokyo 150-0011	+81364274455	+81364274456	infojp@radiall.com

### AMERICAS

<b>USA &amp; CANADA</b> Radiall USA, Inc. 8950 South 52nd Street, Ste. 401 Tempe, AZ 85284	+14806829400	+14806829403	infousa@radiall.com
--	--------------	--------------	---------------------

## GLOBAL PRESENCE

*Australia · Austria · Belgium · Brazil · Czech Republic · Denmark · Estonia · Greece · Hungary · Indonesia · Israel · Korea · Latvia · Lithuania  
Malaysia · Norway · Philippines · Poland · Portugal · Russia · Singapore · Spain · Switzerland · Taiwan · Thailand · Vietnam · South Africa*



# COAXIAL SWITCHES

*Full Line Catalog*